

### SPECIFICATIONS

Frequency coverage: 50-54 MHz

Power input: 1000 W PEP SSB 700 W CW

Input impedance: 50 ohm tuned-input, low pass pi-network type

Output impedance: adjustable pi-network, matches 50-70 ohm with SWR of 2:1 or less.

Intermodulation distortion products: In excess of -30 dB below PEP

Power requirements: 120 VAC 50/60 Hertz 15 amps or 240 VAC 50/60 Hertz 7.5 amps

Tubes: Four 6MJ6 - included with amplifier

Dimensions: W 11" H 5.00" D 9.75"

Weight: 22 lbs.

### WARNING

For proper operation of the cooling system, the econo-amp must be placed on a flat smooth surface. Do not operate on a surface such as carpeting as this will impede the air flow through the cooling holes located in the bottom of the chassis.

### WARNING

Make no attempt to put this amplifier into operation outside of it's cabinet. Contact with voltages inside this amplifier can be fatal.

### UNPACKING

Carefully unpack the econo-amp and examine contents for evidence of shipping damage. If any damage is discovered, notify the transportation company that delivered the equipment. Be sure to keep the carton and packing material as the transportation company that delivered the equipment will want to examine them. Keep the carton and packing even if no shipping damage occurs. Having the original carton available simplifies repacking the equipment for storage or to return it to the factory for service.

Remove the 12 screws holding the top cover in place. Remove the packing material located over the tubes and under the tuned input PC board. Install the fuse supplied which is attached to the transformer inside the amp. Replace the top cover with the vent holes near the rear.

## INSTALLATION

The econo-amp is wired to operate from 117VAC. If 234 VAC is desired, you will have to rewire the power transformer primary as shown below. The terminal strip is located in front of the power transformer on the chassis.

1. Position the econo amp so the rear and the bottom of the unit are clear of all obstructions. This will assure adequate air circulation.
2. Connect a wattmeter and a 50 ohm load to the RF output connector using RG 8u or its equivalent.
3. Connect the econo amp RF IN connector to the exciter RF output using 50 ohm coax.
4. Connect as short a ground lead as possible from a good earth ground to the econo amp GND connector.

### NOTE

#### DISCONNECT UNIT FROM AC LINE

Remove either 117 VAC or 234 VAC jumper(s) before changing from one to another.

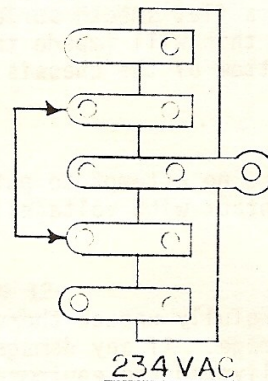
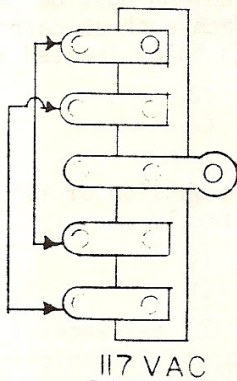

### TUNING PROCEDURE

1. Plug the econo amp into a 117VAC source.
2. Set the Pwr/on switch to the on position.  
Set the STY/OPT switch to the STY positions.

#### ALWAYS ALLOW 3 MINUTES WARM-UP TIME BEFORE APPLYING DRIVE POWER TO THE ECONO-AMP

3. Set the Meter switch to the V (volts) position. The plate voltage meter should read approximately 1200 VDC.
4. Tune your exciter in the Tune or CW mode as stated in your exciter's manual.
5. Reduce CW output using the carrier or CW level control on your exciter. Unkey your exciter.

6. Preset the econo amp meter switch to the I (current) position. Key your exciter and begin to increase the CW carrier level until reaching approximately 300mA on the plate current. Quickly turn the TUNE and LOAD control for maximum output on your wattmeter. Continue to increase your exciter's output until you reach approximately 600mA ( $.6A \times 1166v = 700$  watt DC input).

7. Repeat your Tune and Load controls for maximum output.

To operate SSB, tune the econo amp as stated above. When fully tuned in CW, simply change your exciter to SSB. No further adjustments to the econo amp are required.

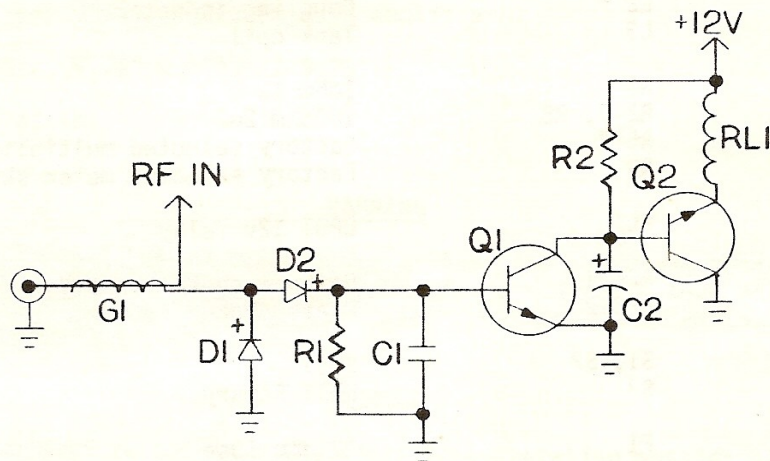

OPTIONAL RF KEYING CIRCUIT

NOTE: RL 1 us the same existing T/R relay in unit.

### ECONO AMP 6 METERS

C1-3, C6-13	.01 uf 1Kv disc
C4	2200uf 50v elect
C5	#426 trimmer
C14	.001 4kv disc
C15	.001 7.5kv disc
C16-18	125uf 500v elect.
C19	34pf variable (wide spaced) tuned cap.
C20	200pf variable (narrow spaced) load cap.
D1, D3-10	3A 1000 piv diode
D2	1N3321 zener
L1	Input inductor
L2	Coupling inductor
L3	Tank coil
R1	1ohm 1w
R2-4, R8	100ohm 2w
R5-7	Factory selected multiplier resistors
R9	Factory selected meter shunt
RL1	DPDT 12v relay
RFC-1	Cathode choke torroid
RFC-2	Plate choke
S1, S2	SPST
S3	DPDT Rotary
F1	10 amp fuse
M1	Plate meter
V1-V4	6MJ6
X1	Transmit lamp 12v
T1	Pwr transformer

#### MISC.

Fuse holder  
Line cord  
Power supply/Tube PC Board  
Plate clips

### RF KEYING CIRCUIT

- C1..... .01 1kv
- C2..... 10uf TANT
- D1, D2..... 1N 60
- G1..... RF Pick-up Loop
- Q1..... MPS A13
- Q2..... ECG 210
- R1, R2..... Determined by Switching Time
- RL1..... Existing T/R Relay in Amp

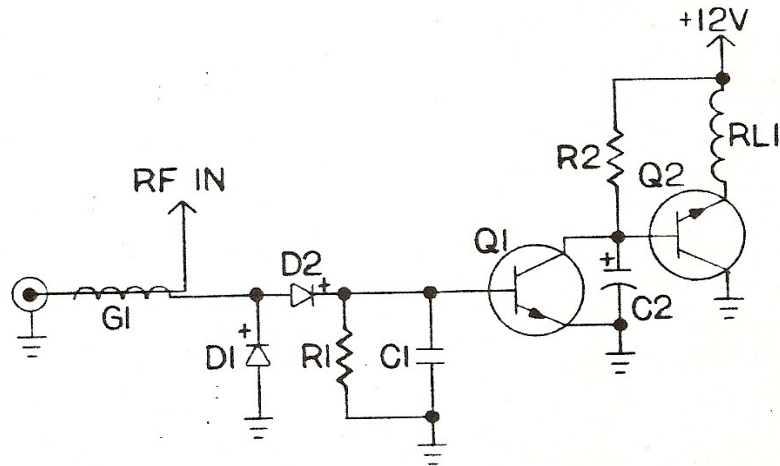

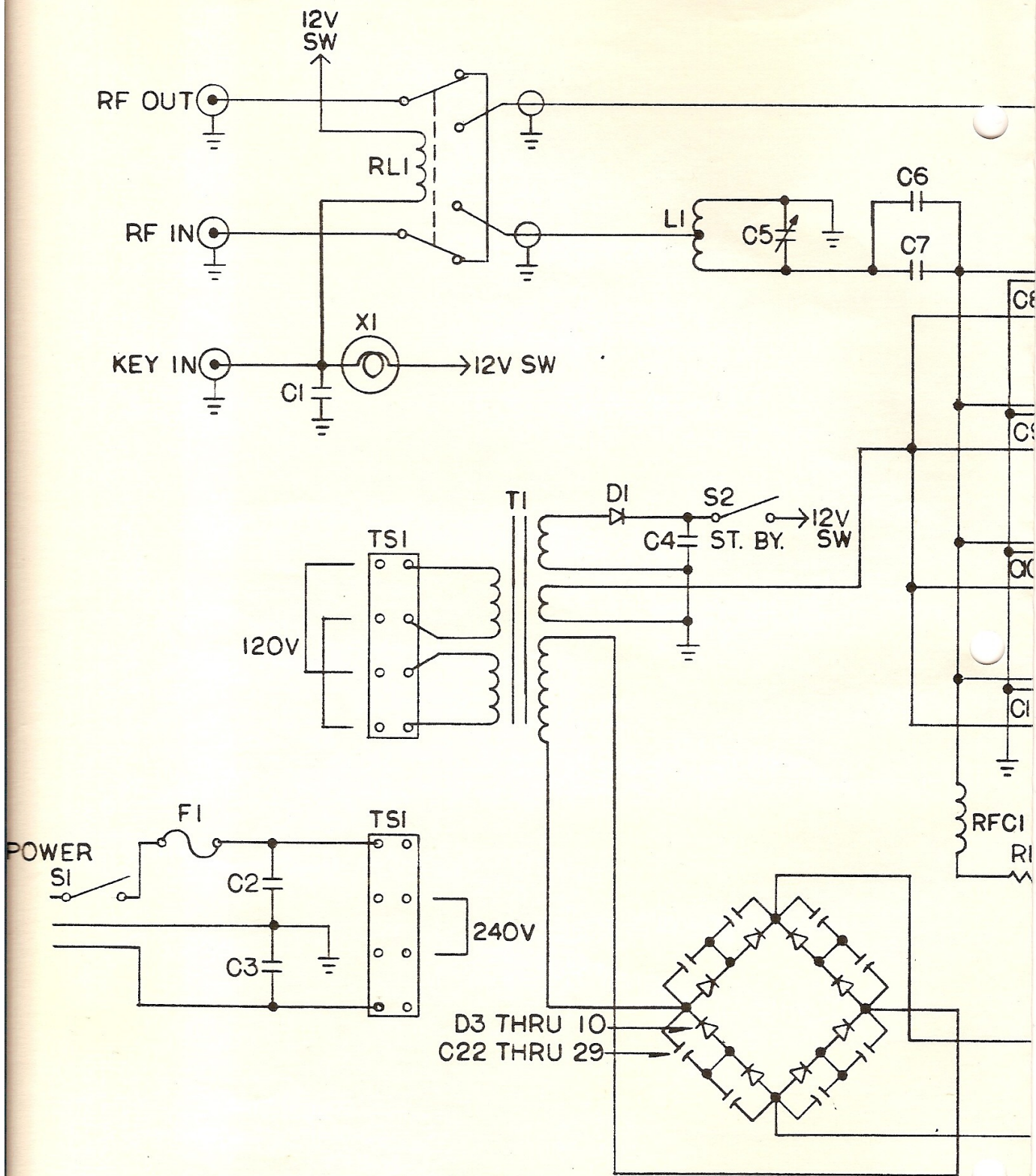

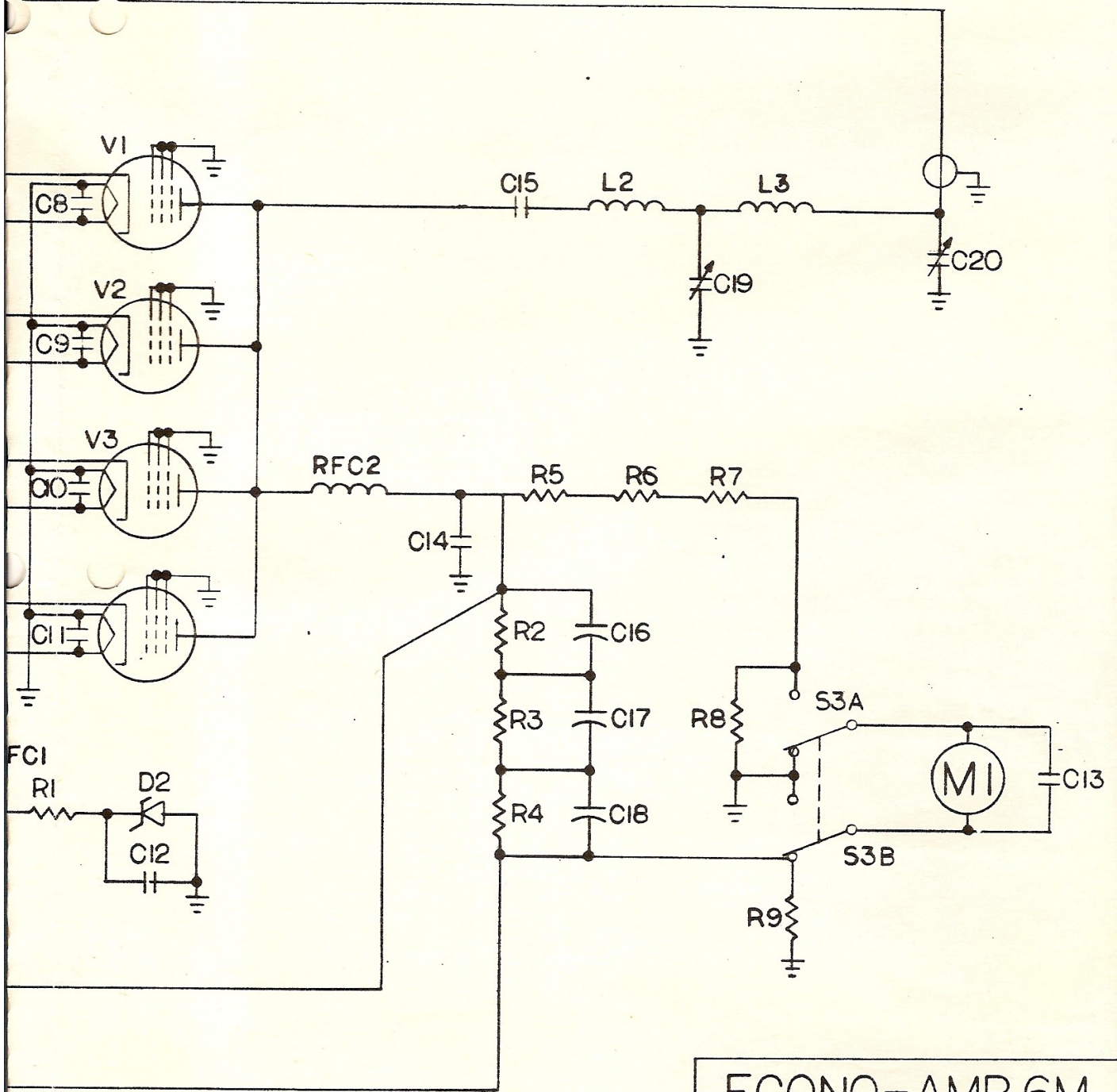

# ECONO-AMP 6M

ECONO-AMP SCHEM.

CHD  
APP.

3/30/83