

# PN2060 User Manual

pn2060a@gmail.com

## Summary

The PN2060C PNA measures the amplitude, phase noise of high-performance RF sources.



## Features

Independent input and reference frequencies from 1 to 200MHz

No phase-locking or measurement calibration required

Dual reference oscillator inputs allow cross-correlation measurements

Measurement results are saved to file automatically

Scripts are provided for post-data manipulation, raw data (full 4 channels baseband, 32Mbytes/S) can be exported for further analysis

USB3.0 interface with high-speed data exchange

Allan deviation: two channel cross-correlation supported

## Measurements

Phase noise at offsets from 0.01Hz to 1MHz and levels typically below -185dBc/Hz (10MHz floor)

One high quality USB3.0 cable is enough to complete data collection and power supply

## System Noise Floor Specification:

Offset	10MHz carrier (90minutes)
1Hz	-130
10Hz	-150
100Hz	-165
1KHz	-175
10KHz	-180
>100KHz	-180

**Electrical Specifications:** Input Signal Level: 10dBm (max), Input Impedance: 50

## Mechanical Specifications

Size: 11 x 10 x 4 (cm), Power: USB3.0 power supply with about 1.3A. Operating Temperature: 0-30deg

Unit Weight: 0.5kg.

**Front Panel:** SMA RF connector ( DUT1, DUT2, REF1, REF2)

**Real Panel:** Type-C ( USB3.0 to Type-C cable needed)

## **(I) Hardware Requirements and Driver Installation**

### **1.1 System Hardware Requirements**

The system software involves high data throughput and extensive scientific computations, which need to be completed in real time. This places high demands on the CPU, memory, and motherboard power supply.

#### **Supported Operating Systems:**

- Windows 7 / Windows 10 / Windows 11/12

#### **Recommended Computer Configuration:**

- **CPU:** Intel 12th Gen i5 or higher
- **Memory:** 8GB or more
- **Recommended Motherboard:** B760M series

#### **USB 3.0 Power Requirements:**

This device requires a connection to a USB 3.0 interface, and the computer's USB 3.0 power supply capability is critical. Some motherboards (e.g., H610 series) may have insufficient power delivery. In such cases, install a USB 3.0 expansion card or use a B760M series motherboard. Since the USB 3.0 power supply is shared among all connected devices, disconnecting other devices can help meet the power requirements for this device. The USB 3.0 expansion card shown below has been extensively tested and confirmed to work effectively.



#### **Notes:**

1. For computers with lower performance, you can select the "Slow" option in the software interface. This reduces the data throughput by half, allowing older computers to function properly.
2. If your operating system runs numerous background services or high-load programs, it may interrupt the system operation, leading to a "Data Packet Loss" error. To resolve this, close the software, disconnect the USB cable, reconnect it, and restart the software.
3. Use the rear panel USB 3.0 ports on desktop computers rather than the front panel ports for better performance.

## Laptop Requirements:

Due to the wide variety of laptop models, individual verification is not possible. Note that the power design of laptops differs significantly from desktop computers, and desktop power supplies typically exhibit much lower noise. When using a laptop, it is recommended to disconnect the external AC adapter.

**Note 4:** Use the built-in USB 3.0 ports of the laptop or desktop. Most commercially available USB expansion interfaces (as shown below) do not work correctly with this system.

## 1.2 Driver installation

- 1) Connect PN2060 to laptop, and please go to Device Manager, find “FX3”. Then step by step in the following.

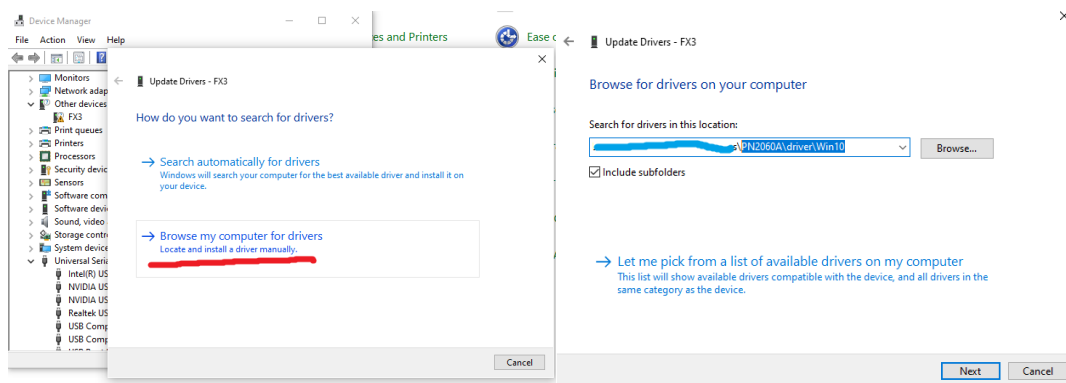
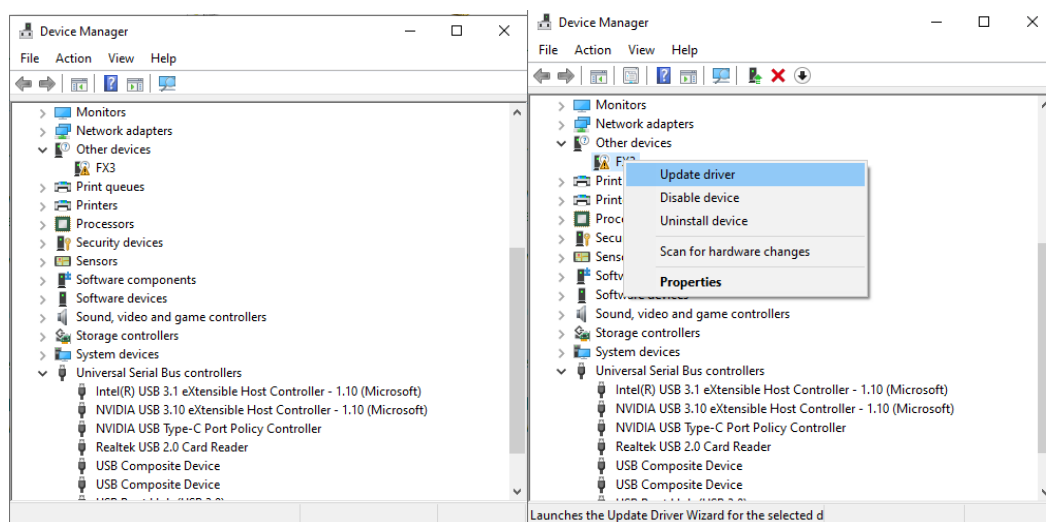

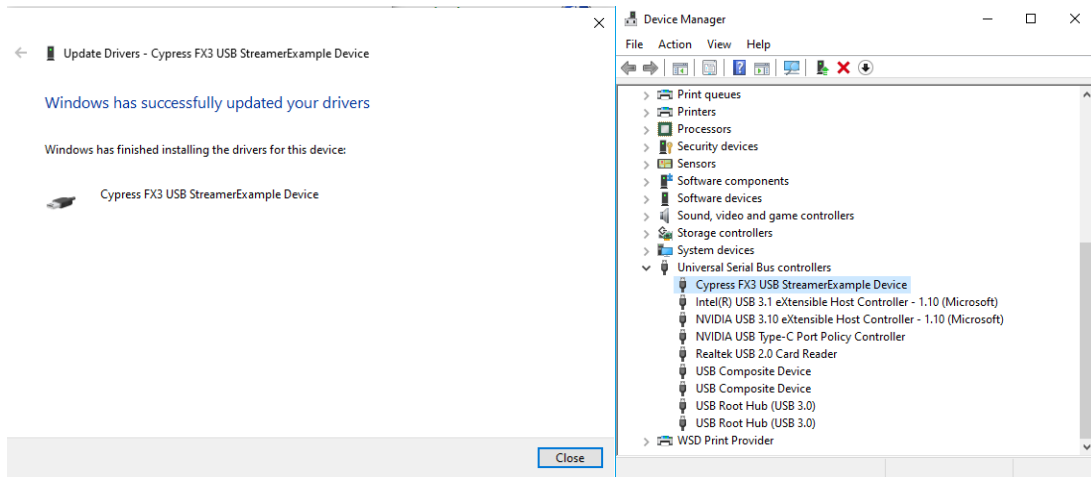

- 2) When the driver installation is completed, un-plug USB3.0 cable, and recycle laptop (**very important**)
- 3) Connect the device with the laptop, and try to run pn2060.exe in the SW package.

## (II) Test Setup

To achieve accurate test results, please follow the recommended test settings below. Any environmental interference (such as transformers, switching power supplies, vibrations, air disturbances, etc.), as well as issues with cables and power supplies, can introduce significant noise that is difficult to eliminate.

Whenever possible, power both the reference source and the device under test (DUT) using batteries or high-performance power supplies from the HP/Agilent series.

### 2.1 Dual references are preferred

Extensive testing has shown that dual-reference source testing is the most reliable and effective method, with the fewest issues encountered. Whenever possible, opt for this testing approach.

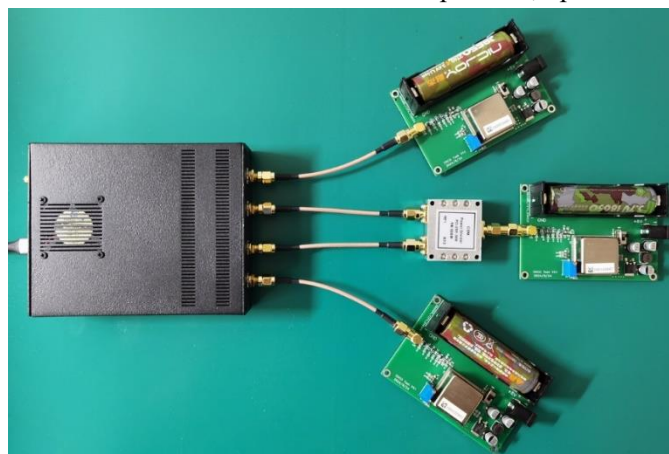

- 1) The DUT should be powered by batteries or an ultra-pure power supply whenever possible; the "independence" of the two reference sources is crucial! Do not share a power supply!
- 2) Split the DUT into two paths using a power splitter; connect to DUT1 and DUT2 on the device.
- 3) Connect the reference sources to REF1 and REF2, separately; try to maintain maximum input power at the reference ports. A decrease in input power will reduce the system's dynamic range.

If the reference output power exceeds 10 dBm, series an attenuator before connecting to the device to avoid overload, which can lead to test failure or damage.

- 4) The reference source and DUT must be effectively filtered to avoid measurement errors; some sine wave output signal sources may require filtering due to poor quality.
- 5) After starting the software, enter the reference frequency (REF FREQ) in Hz and the DUT frequency (DUT FREQ); confirm the system clock is correct and click "Apply" to complete the setup.
- 6) Click "Start" to begin testing; note that the internal clock may take about 30 minutes to stabilize. Testing immediately after powering on can lead to rapid data drift and measurement failure.
- 7) Testing typically lasts from a few minutes to several hours. After testing, the system generates a PNDATA.csv file and a PNP format data file (which can be opened with other frequency analysis software).

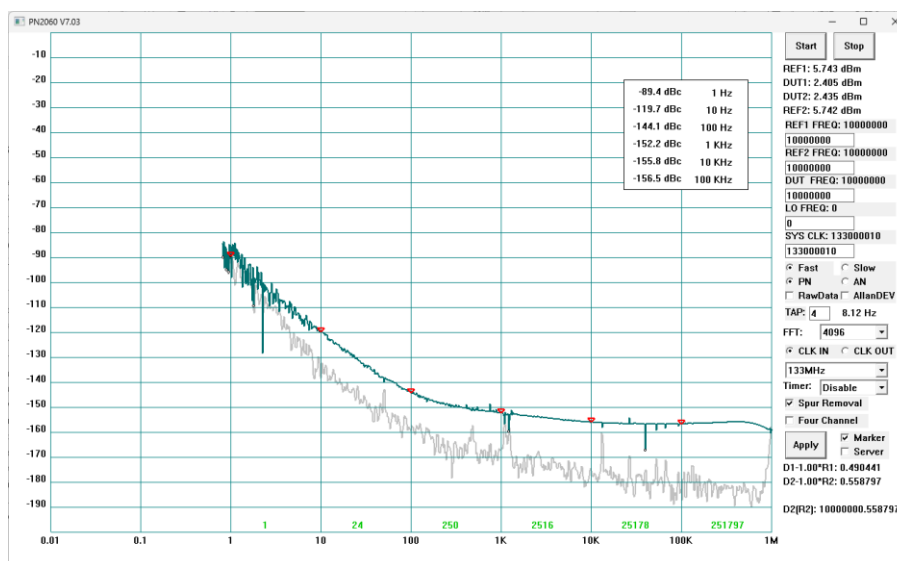

### (III) Other Setup

- 1) **Fast and Slow Settings:** If your computer performance is insufficient, select "Slow" and click "Apply." Then, close the software, disconnect the USB cable, reconnect the USB cable, and restart the software before retesting.
- 2) **2048, 4096, 8192 Options:** Selecting higher values increases the system's frequency resolution but also extends the testing time.
- 3) **Testing Time:** The time required for each tenfold frequency reduction (e.g., from 1 Hz to 0.1 Hz) increases exponentially and demands higher system stability. Since the system operates with multiple internal clocks, maintain a relatively stable ambient temperature, avoid environmental vibrations and disturbances, and ensure both the Device Under Test (DUT) and the reference source are adequately warmed up for optimal testing results.
- 4) **Amplitude Noise (AN) Measurement Function:** After switching the PN/AN test settings, the software must be closed and restarted for the changes to take effect. Failure to restart may result in an error ("Data Loss"). Currently, the amplitude noise feature is in the experimental stage, and the test results are for reference only.\*
- 5) **CLK IN, CLK OUT:** continue developing, not supported.

- 6) **Raw Data:** check the box and press “Apply”, then “start”. Data streams (about 32Mbytes/s) will be written to your disk (solid-state-disk is necessary).
- 7) **Allan Deviation:** Select "AllanDEV" and click "Apply." Pay attention to the TAP value (1–4), which will filter the raw data. The equivalent noise bandwidth (ENBW) is displayed afterward. A larger filter bandwidth results in faster updates but with greater trace noise; conversely, a smaller bandwidth leads to slower updates but smoother traces.

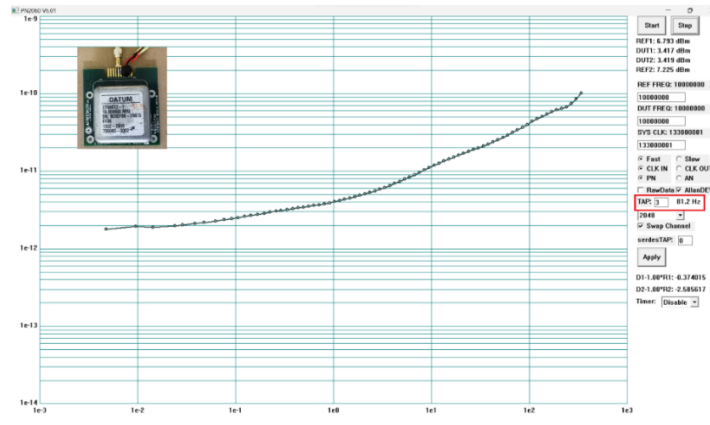

- 8) **“Four Channel”:** data streams of the four channels will be uploaded to PC simultaneously.
- 9) **“Spur Removal”:** instrument generated spurs will be removed (experiment only)
- 10) **“Server”:** Data stream (TCP) can be sent to other applications.
- 11) **“Marker”:** phase noise @ 1Hz, 10Hz, 100Hz, 1KHz, 10KHz, 100KHz will be displayed. Try to adjust the size of the window, the position of the spot noise will change accordingly.
- 12) **Frequency Counter Function:** After selecting "Four Channel," the interface will display the frequencies of REF2 and DUT. When the REF1 frequency is sufficiently accurate, the displayed values will be highly precise, and the frequency counter performance will exceed that of conventional frequency counters.

#### Notes:

- 1) Please check the USB3.0 interface carefully, it doesn’t work with a type-C interface on a laptop, doesn’t work with usb-hubs, and doesn’t work with USB2.0 interface.
- 2) Please try to do a 180deg rotation of the type-C interface if encounter problems, after plug-in, wait 3-5 seconds before running the application (always check the driver in the “device manager”).
- 3) Dual reference sources can reduce noise by increasing the measurement duration. The most critical performance of the reference source is around the 1 Hz offset, because data updates near 1 Hz are slow, requiring a long time to average down the noise. At the 100 kHz to 1 MHz offset, slightly worse phase noise is acceptable, as the frequency is updated approximately 1,000 times per second, allowing the noise to average out quickly. The frequency difference between the reference source and the DUT should be less than 16 times.

It is recommended to use a 10 MHz reference source for testing frequencies not exceeding 30 MHz. The reason is that the equivalent performance of a 10 MHz reference degrades by about 10 dB when scaled to 30 MHz. If a 10 MHz reference is used to test 100 MHz, the performance degradation would be about 20 dB, making far-end noise floor measurement difficult.

#### (IV) Self-Loop Performance Limit Testing Method and Considerations

Self-loop testing method: Please refer to the diagram below for system self-loop limit test verification. Use three identical power splitters to divide the signal into four paths entering the device, and ensure the signal amplitude is sufficiently large (close to 10 dBm). The crystal oscillator output signal needs to be amplified and thoroughly filtered. Important considerations: 1) The longer the test duration, the lower the self-loop noise floor near 1 Hz. 2) Perform the test after the device and the crystal oscillator are fully warmed up. 3) Ensure the four signal paths have minimal phase difference (equal-length cables) and no significant amplitude differences.

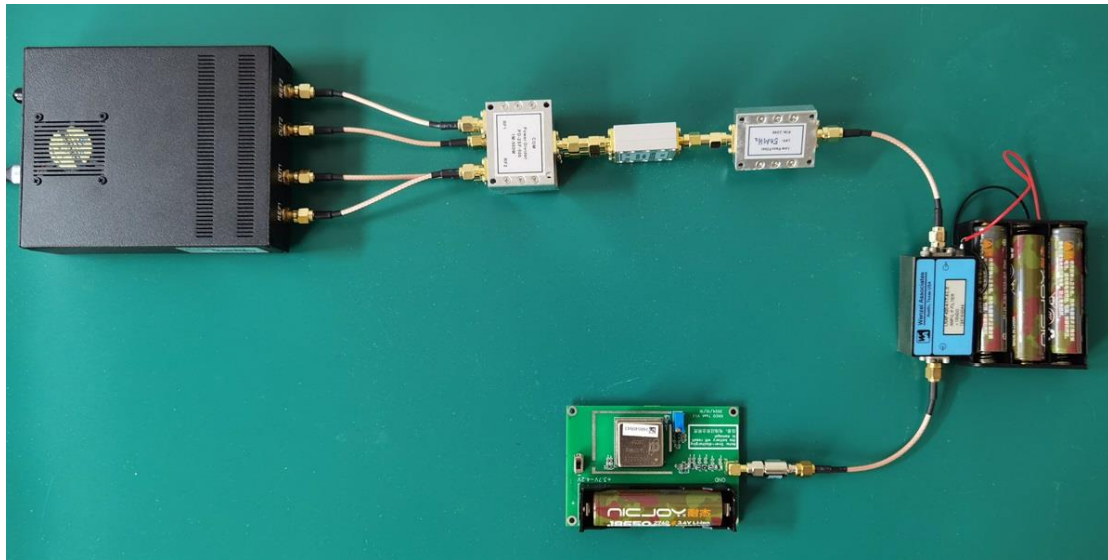

**Update for some mainboards:** With the hardware version  $\geq 1.4$  (after June, 2024), the power supply of the system is optimized already, and most of the PCs can run properly.



#### **Acknowledgement:**

I would like to thank for Andrew Holme. In the very beginning of the development of the PNA, I have learned a lot from Andrew's wonderful work and also asked for some helps. In the process of my design, I have gradually developed my own codes from PN2060A to PN2060C. But still use part of Andrew's source codes in current release. Andrew has granted permission for me to use his source codes. I would thanks to Jim Henderson, Pual Hsieh, and Drew Wollin for their valuable feedbacks and discussions, where Jim Henderson implemented a mixer-based down-converter to extend the frequency range. Drew Wollin has written an introduction and review for beginners. Pual Hsieh has some valuable discussions with me for potential improvement. I am also would like to thanks IW3AUT for the file converter tool which makes it compatible with other applications.

## Appendix 1: Common Testing Issues and Precautions

This device has high power supply requirements for the computer's **USB 3.0 ports**. It's important to note that many motherboards share the power supply for USB 3.0 ports. If other power-hungry devices are connected, it may also lead to insufficient power supply.

It is possible to use a USB 3.0 expansion card with adequate power supply capability. If insufficient power supply is detected on the desktop, inserting this expansion card will provide sufficient power.



Signs of Insufficient Power Supply:

1. Device not recognized.
2. Driver cannot be installed properly.
3. After successful driver installation, the program crashes (the program starts, power consumption increases by about 40%, and the computer becomes unresponsive).  
If you have installed drivers like **libusb-win32**, please remove them in Device Manager, as they may cause conflicts. Use the provided data cable, as not all data cables are compatible!
4. The Type-C connector has 24 connections, and contact issues may occasionally occur. Try rotating the Type-C connector 180 degrees before plugging it into the device, or switch to a different USB 3.0 port on your computer. For example, you might occasionally see the interface display four channel power values as "Inf."

Laptops vary widely in design, and since this device requires a current close to the USB 3.0 limits, there may be situations where stable long-term operation is not possible (evident by test interruptions after a period of time). Testing shows that the noise performance of laptop power supplies is generally worse than that of desktop power supplies. Therefore, using a laptop for testing can introduce more noise, leading to decreased system performance. Noise can enter the system through the data cable, which is why a USB 3.0 power supply solution was used in the system design instead of a separate power supply. Testing with a laptop's battery versus an external power supply can sometimes yield significant differences in noise floor, closely related to the external power supply and the laptop itself. Conduct several comparative tests (desktop vs. laptop) to ensure the reliability of the test results. **When using laptops, don't connect it with external switching power supply.**

**Using external Power Supply:** (Not recommended, potential risk of introducing additional noise)  
Enable the device's dedicated power supply port using a "clean" linear power supply (do not use phone chargers or other switching power supplies).

Steps:

1. First, power the dedicated power supply port.
2. Connect the data cable for communication; the power supply on the data line will automatically disconnect at this time. The linear power supply used in this test is for

reference only\*.



**NOTE: with the hardware version  $\geq 1.4$ , the power supply of the system is optimized already, and most of the PCs can run properly.**

This system requires real-time processing of high-speed data streams of 16 Mbytes/s (2 channels) or 32 Mbytes/s (4 channels), which demands a high-performance computer. It is recommended to use a device with an i5-12th generation CPU or higher, along with a solid-state drive (SSD), and dedicate the device exclusively to this task. Avoid installing numerous other background services on the testing computer, as these services may compete for CPU resources and cause interruptions in the measurement process. By disabling the "Spur Removal" option in the interface, the performance demand on the computer can be reduced. If necessary, selecting the "slow" option in the interface will significantly lower the computer's performance requirements.

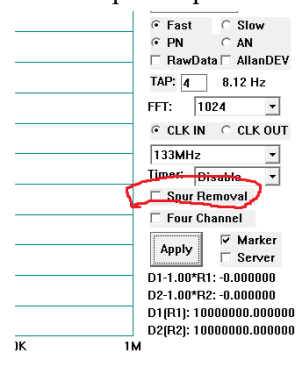

To avoid measurement errors, ensure effective filtering of the DUT signal. For example, when testing a 10 MHz signal or a 24.576 MHz signal, use a Mini-Circuits SLP-30M filter before entering the device, or similar filters from other brands. Direct testing without filtering will yield results that include the total noise of the signal and its harmonic components, potentially introducing errors of 3-5 dB at the far end of the frequency offset (100 kHz - 1 MHz) due to harmonic levels & aliasing frequencies.

For optimal measurement results, the reference source performance should not be worse than that of the DUT, particularly around the 1 Hz offset; otherwise, excessively long measurement times (e.g., >8 hours) become unacceptable.

Regarding power splitters, isolation is a key parameter; always opt for high-isolation splitters!

Impedance matching is crucial: if the DUT output impedance deviates from 50 ohms, directly connecting it to the splitter can cause significant mismatch errors. In such cases, good isolation from the splitter is essential to minimize errors. If the DUT impedance is satisfactory, the splitter isolation requirements can be relaxed. Using a 6 dB attenuator in series with the DUT can improve impedance matching effectively.

The "independence" of the two reference sources is very important! Do not share a power supply. During performance validation tests, it is best to power the system with 18650 rechargeable batteries.

For a 10 MHz reference source, the maximum measurement signal should be <160 MHz. For testing signal sources  $\geq 160$  MHz, a 100 MHz reference source should be used.

## Appendix 2: How to Extend Frequency Range

### (I) Basic Test Setup:

- 1) Use a 100 MHz reference source (the diagram for 100 MHz is for reference only and has general specifications).
- 2) Utilize a corresponding bandpass filter; for example, when testing a 500 MHz signal, use a 480 MHz - 520 MHz bandpass filter.

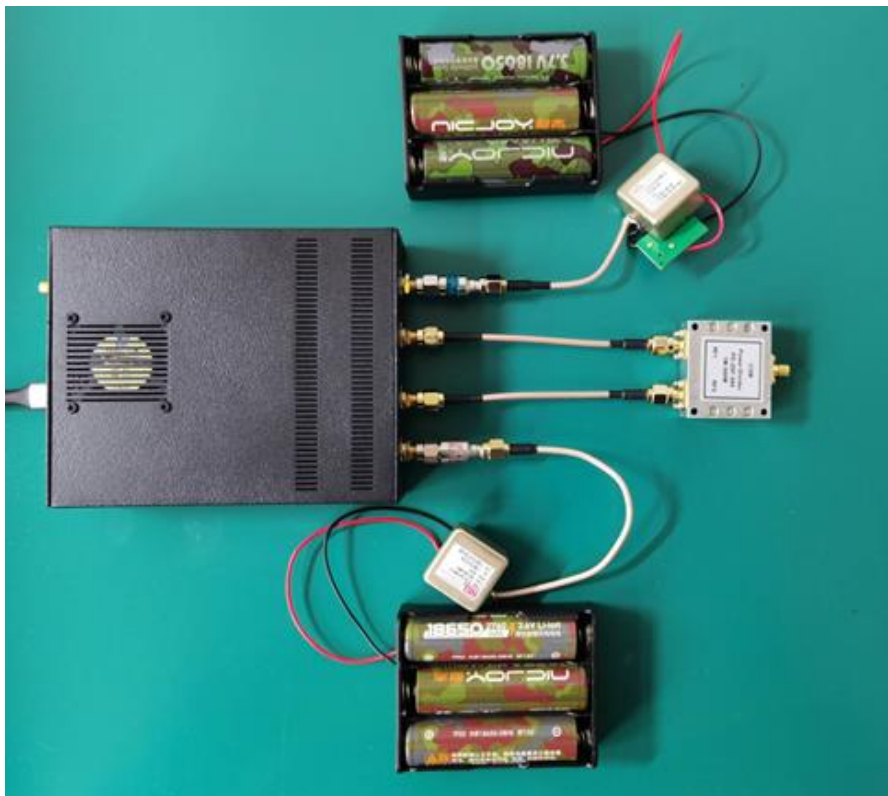

Whenever possible, use a high-performance 100 MHz reference source, such as the models listed below for reference.



As the measurement frequency increases, the device's testing capability gradually decreases. This device can directly support testing of 1 GHz signals (using a 100 MHz reference source and requiring an effective bandpass filter). The diagram below shows an example of testing the Crystek CCSO-914X3 1G DRO. Note that the actual DRO output power is approximately 10 dBm; after a 3 dB attenuation through the power splitter, the signal entering the device is only -28 dBm. The test results are accurate only when the frequency offset is <10 kHz; accuracy diminishes for offsets greater than 10 kHz!

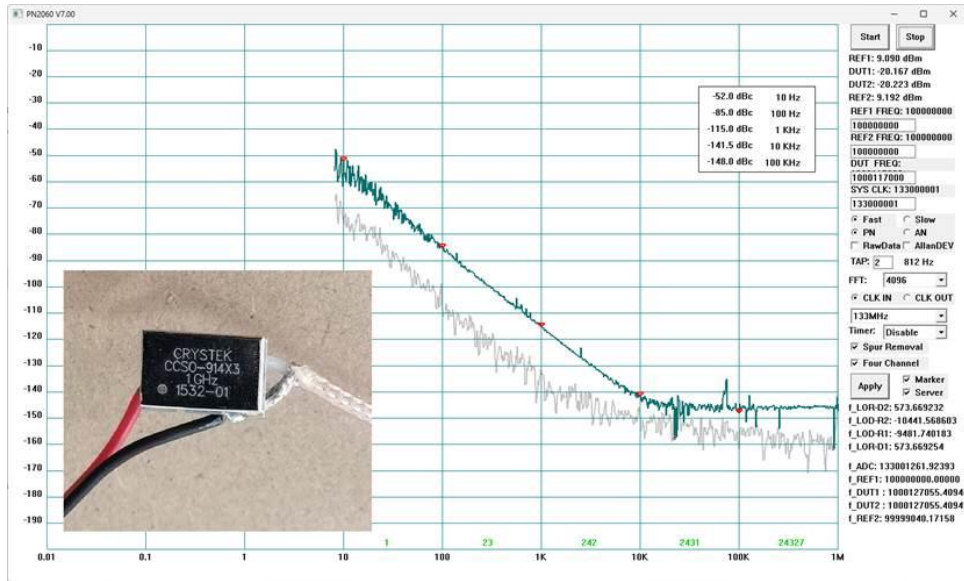

To accurately measure out-of-spec devices, a down-conversion module can be used to convert high-frequency signals to <50 MHz for testing. The diagram below shows the test results after using a dual-channel down-converter, revealing that the device's noise floor is approximately -170 dBc/Hz.

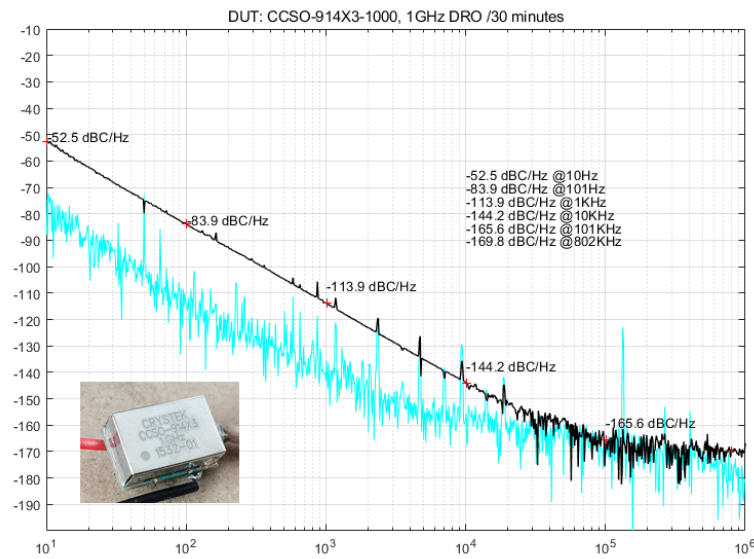

## (II) Down-Conversion Testing Method

1) **\*\*Single-Channel Down-Converter\*\***: Note that the local oscillator (LO) specifications of this device must be at least 6 dB better than the DUT across the entire frequency range. A passive mixer can be used, and after mixing, a low-pass filter (<30 MHz) should be applied to remove spurious signals. The key to single-channel down-conversion is having a local oscillator with very high-performance specifications, such as a Rohde-Schwarz's SMA100B.

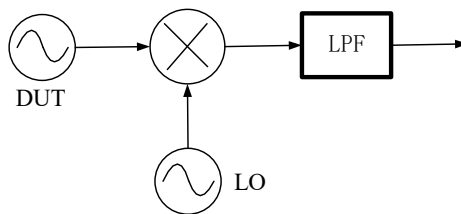

## 2) Dual-Channel Down-Converter

This method allows for testing at a 1 GHz frequency point with a noise floor of -170 dBc/Hz, and it can enhance the testing capability at 100 MHz to -180 dBc/Hz. Measurement comparison with Keysight's E5052:

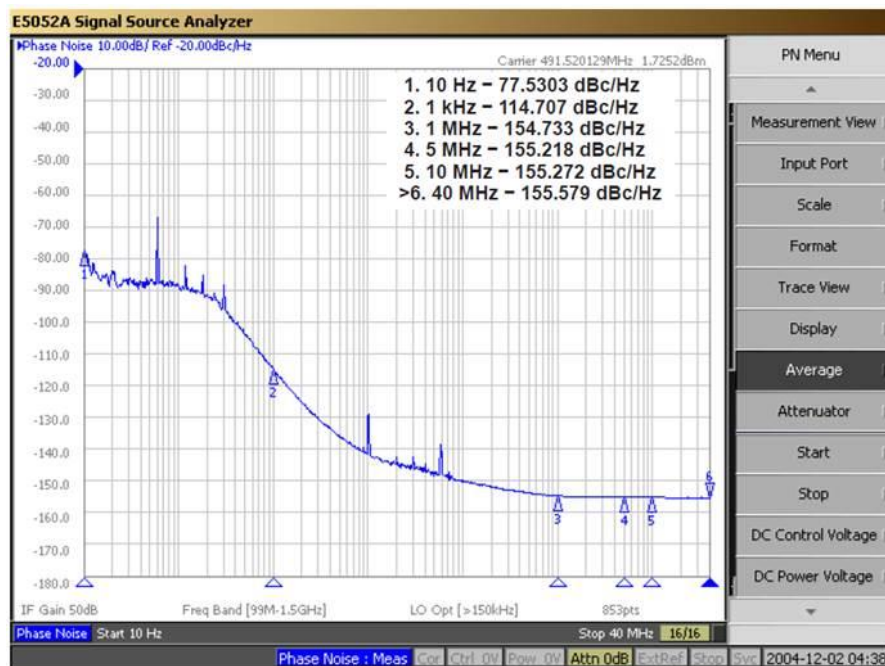
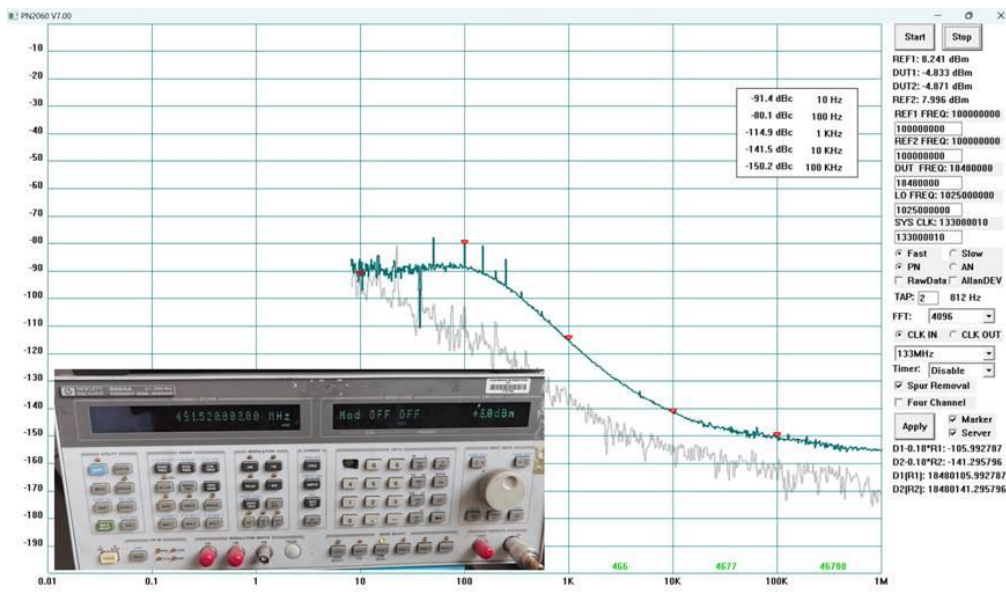

Example2: Comparison with Simulation.

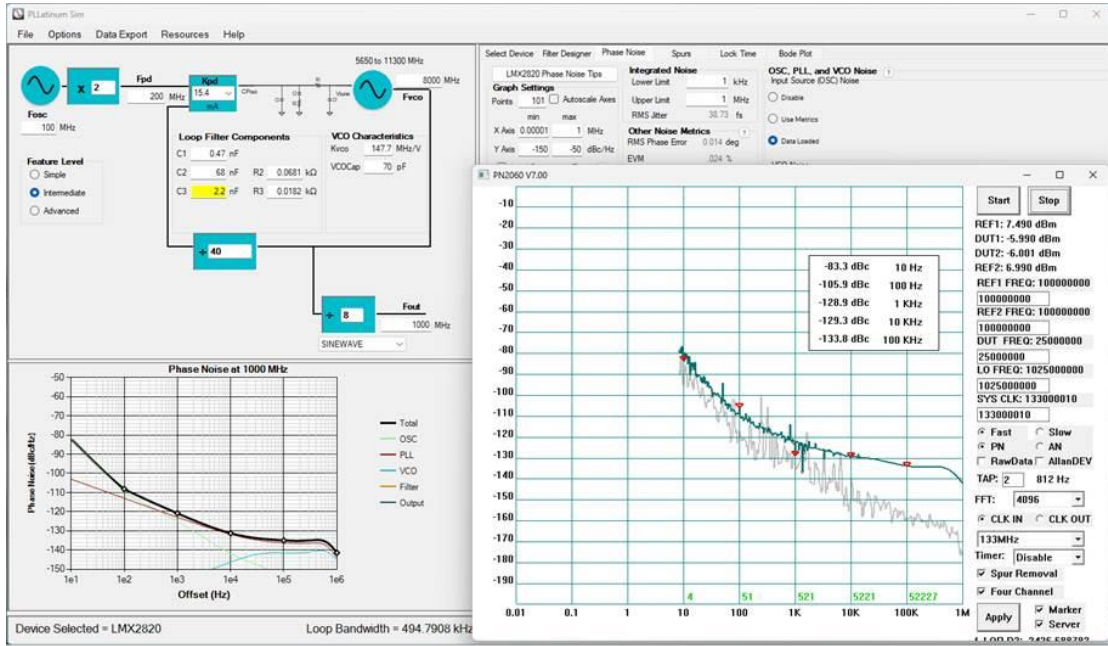

### Appendix 3: Test Failure Cases – Power Supply Impact on Phase Noise

**Common Issues with Low-Cost "Linear Regulators":** These power supplies can significantly degrade phase noise performance, sometimes even more than digital-controlled power supplies. Across the measurement range of frequency offsets (1 Hz to 1 MHz), the degradation can exceed 20 dB in some cases.

**Issues with Certain Digital-Controlled Power Supplies:** These power supplies can introduce significant discrete components into the phase noise spectrum, causing severe interference with test results.

#### Example 1:

Using the Longwei PS-6405F power supply to power the Device Under Test (DUT):

- The test showed noticeable phase noise degradation, with additional discrete components disrupting the measurement.
- This highlights the critical importance of selecting high-quality, low-noise power supplies to ensure accurate results.

Recommendation: Always verify the noise characteristics of the power supply before use, and prioritize high-performance models or battery power when testing.

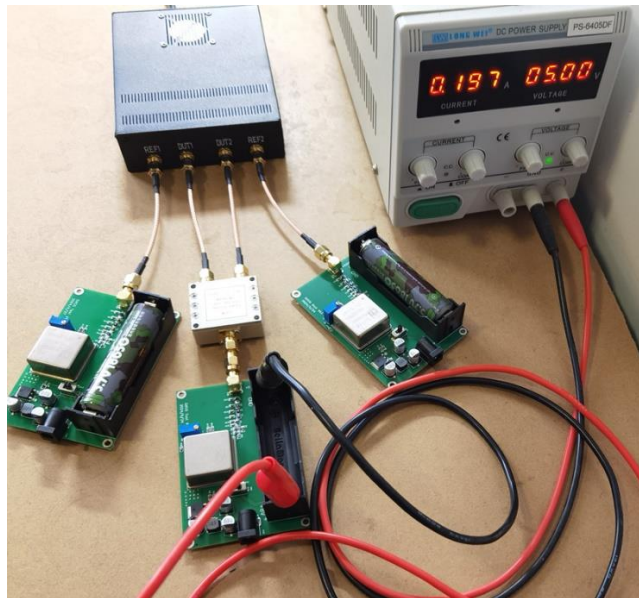

Battery-Powered Scenarios Comparison:

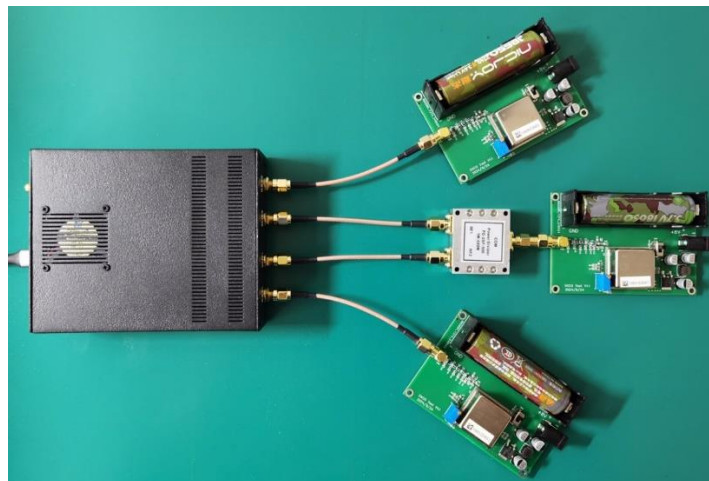

(Longwei PS-6405F) Power Supply:

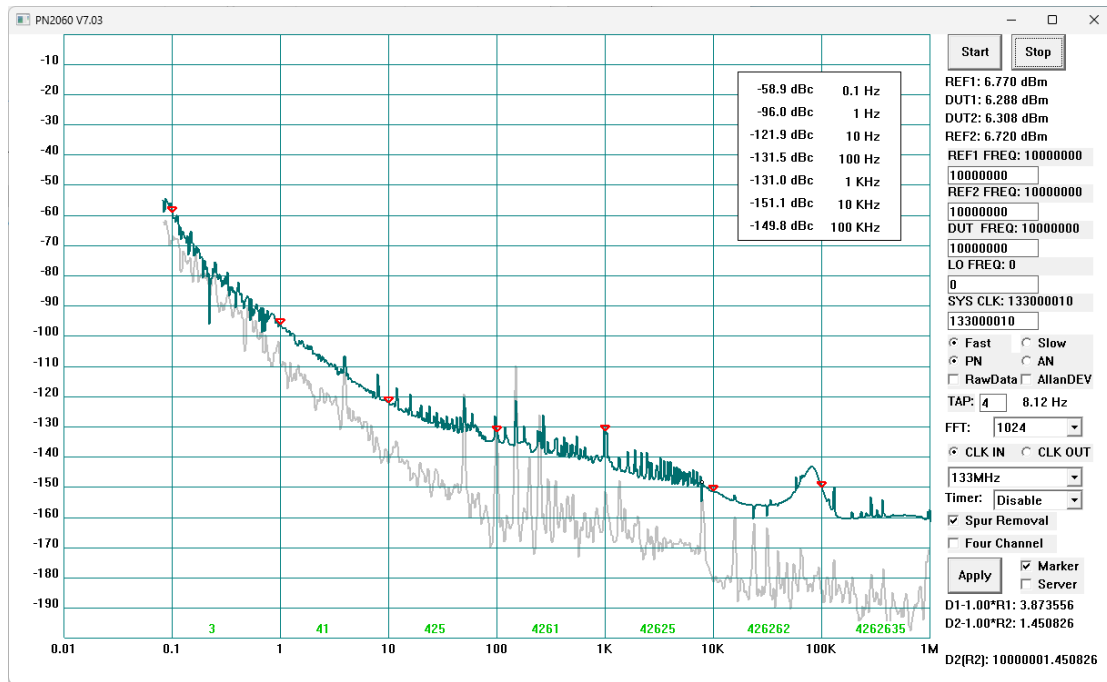

Batteries:



The test differences can exceed 20 dB, and external power supplies can severely impact phase noise measurements!

## Appendix4: Description for different frequency bands

### (1) Advantages and Disadvantages of Digital Phase Noise Analyzers

#### Advantages:

Digital phase noise analyzers do not require analog phase locking for the device under test (DUT). For example, the E5052A/B series products from Keysight have evolved from their predecessor, the HP3048. When testing, the HP3048 requires analog phase locking of the DUT, which introduces significant issues. This can be observed in the following test case (XO5051 100M PPI), where the test results from the E5052B show a significantly inferior curve compared to the FSWP.

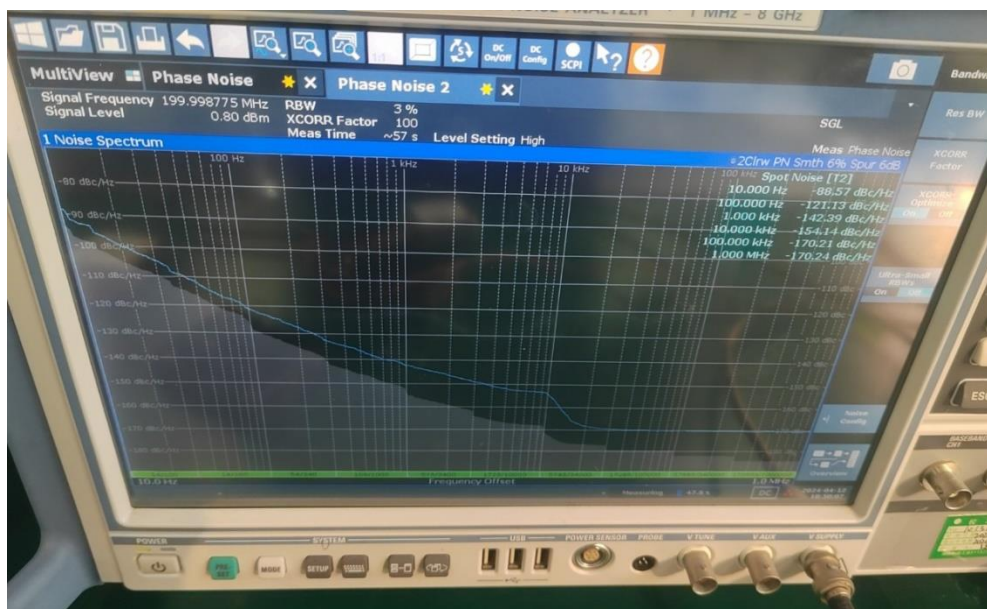

#### Disadvantages:

Fully digital phase noise analyzers are prone to issues such as frequency-domain aliasing and harmonic interference. Additionally, improper parameters for components like power splitters and filters can easily introduce measurement errors.

## (2) Explanation of Different Frequency Bands

Digital phase noise analyzers perform best within the first Nyquist zone, effectively avoiding issues such as frequency-domain aliasing and harmonic interference. For this device, the best testing results are achieved within the 1 MHz to 60 MHz range, where low-pass filters can resolve most issues.

### Frequency Band Details:

1. 1 MHz–67 MHz: First Nyquist sampling zone; the testing results achieve the highest precision.
2. 67 MHz–133 MHz: Second Nyquist (under sampling) is subject to frequency-domain aliasing, which is closely related to the filters connected to the test port.
3. 133 MHz–200 MHz: Third Nyquist (under sampling) is affected by frequency-domain aliasing and ADC aperture jitter. Improper filter selection significantly impacts the test results.

## (3) Solutions

Adopt a method similar to the FSWP product from Rohde & Schwarz: use the digital sampling system exclusively in the first Nyquist zone, while converting other frequency bands down to the first sampling zone.

For example, the following setup can be used to test the second Nyquist zone. When testing a 100 MHz OCXO, excellent results can be obtained. The performance (in terms of results and testing speed) is comparable to that of the Rohde & Schwarz FSWP. This method can fully test the best 100 MHz oscillators on the market, achieving a testing capability of  $>180$  dBc/Hz.

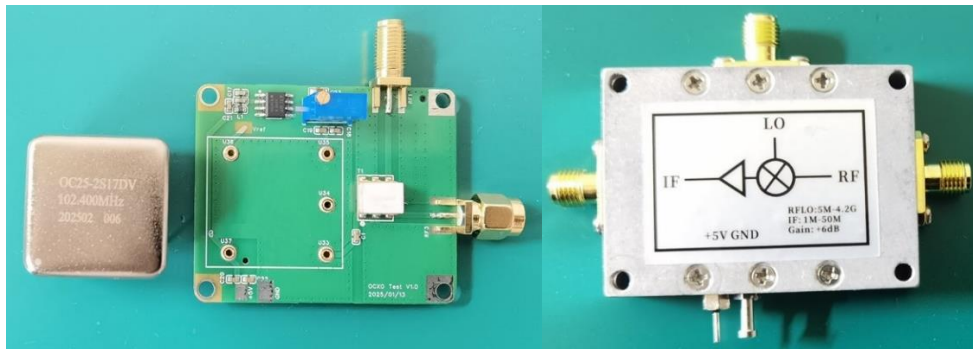

1) **Test Frequency Range 50M-150M:** Please refer to the following test methods. Note that the frequency deviation between the test frequency and the local oscillator (LO) should be greater than 1 MHz. When using two 102.4M references, this is suitable for testing 100M oven-controlled crystal oscillators (OCXOs), but it cannot be used to test the 102.4M frequency point. To test the 102.4M frequency point, two 100M OCXOs should be used as reference sources. If the frequency difference between the DUT and reference source is too large, the test performance will degrade. 120M and 122.88M are suitable for mutual testing, and 102.4M and 100M are suitable for mutual testing. Try to keep the frequency difference within 10 MHz to achieve the best test results.

2) **Reference Oscillator Power:** The power of the reference oscillator should ideally not be less than 10 dBm. A power level that is too low will reduce the dynamic range and test capability.

3) **Input Power to the System:** The input signal power to the system (rightmost power splitter) should be less than 3 dBm. Since most oscillators output powers greater than 7 dBm, ensure to insert an appropriately large attenuator. If the input signal is too strong, the system may overload,

and the test results will become inaccurate. For oscillators with inherently low output power, avoid excessive attenuation.

**4) Frequency Adjustment for Two Reference Sources:** Adjust the frequencies of the two reference sources so that their frequency deviation is approximately 30 Hz. The test results show many spurious components at 30 Hz and its harmonics (60, 90, 120, etc.). Adjusting the spurious components to this position has minimal impact on the test results, and components at 10 Hz, 100 Hz, 1 kHz, etc., can be easily observed.

**5) Frequency Difference Input:** The frequency difference between the DUT and the LO is  $102.4\text{M} - 100\text{M} = 2.4\text{M}$ . Be careful not to input this incorrectly.

**6) Band-Pass (Low-Pass) Filter:** The DUT does not need to be connected to a band-pass (low-pass) filter.

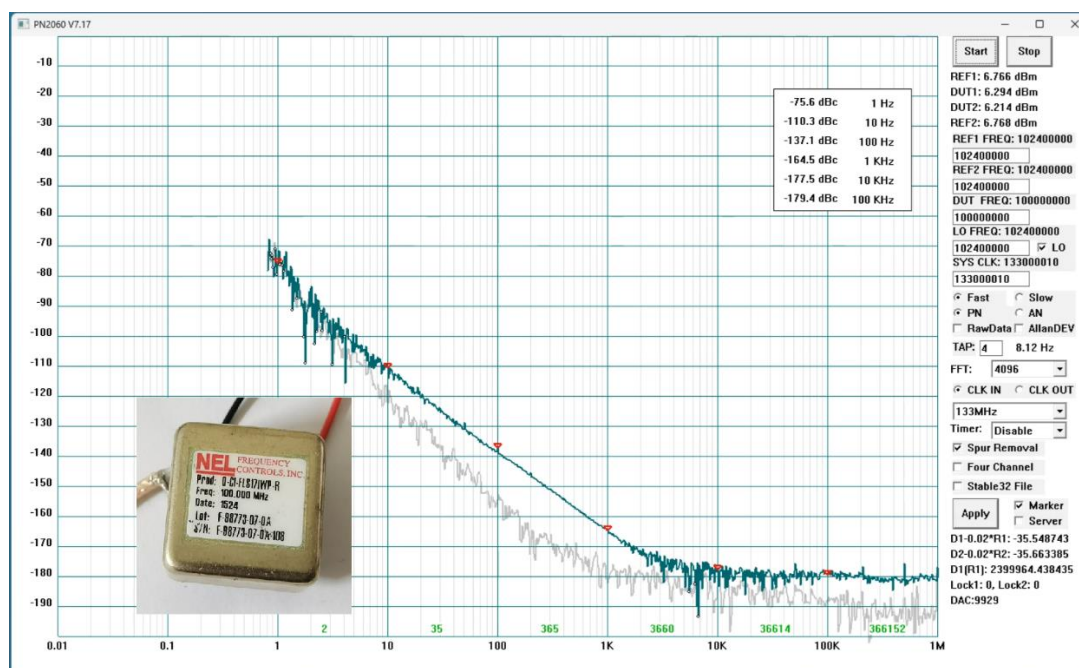

It is possible to measure a noise floor below -180 dBc within a few minutes, and achieve measurements of -170 dBc/Hz at a 1 kHz frequency offset. With new phase-locked design, it is nearly spur-free.

For other test frequency bands, measurements can be performed using OCXOs of different frequencies or through methods such as frequency multiplication of the OCXO. The testing performance is comparable to the Rohde & Schwarz FSWP.

#### Precautions:

- Ensure that the RF test cables are not excessively long.
- Use RF test cables with high shielding performance.

## Appendix5: Capacitor is Critical for Some Crystals

Test setup: Crystal oscillator connected in series with an attenuator (10 dB, for improved impedance matching) and a filter (to eliminate harmonics). The DUT is: SCTF LN 49.152.

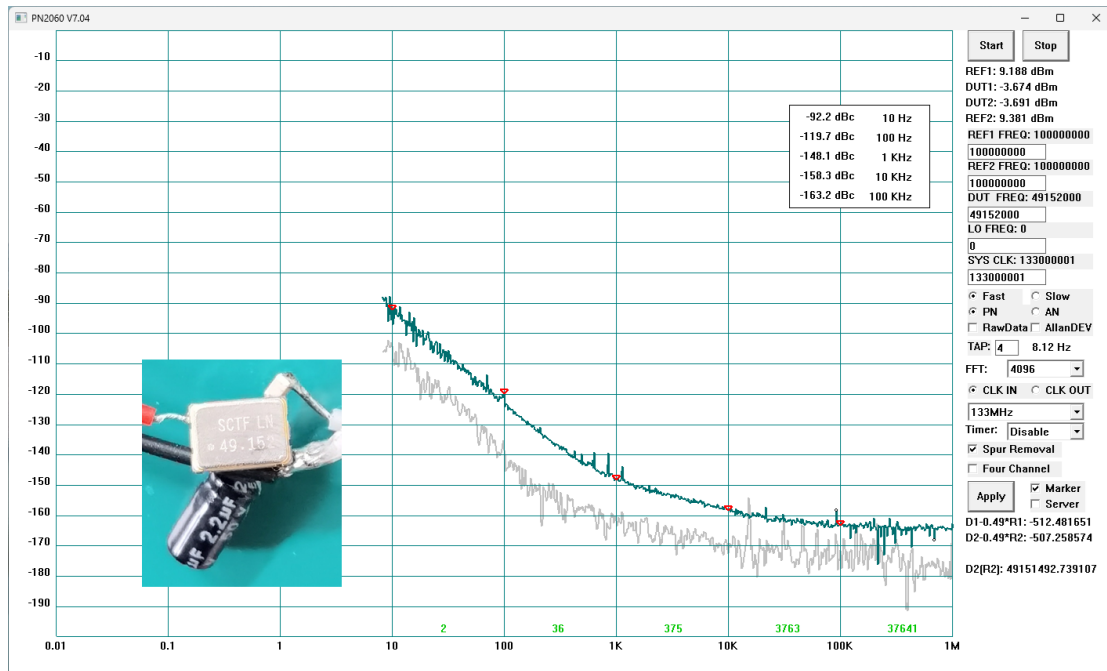
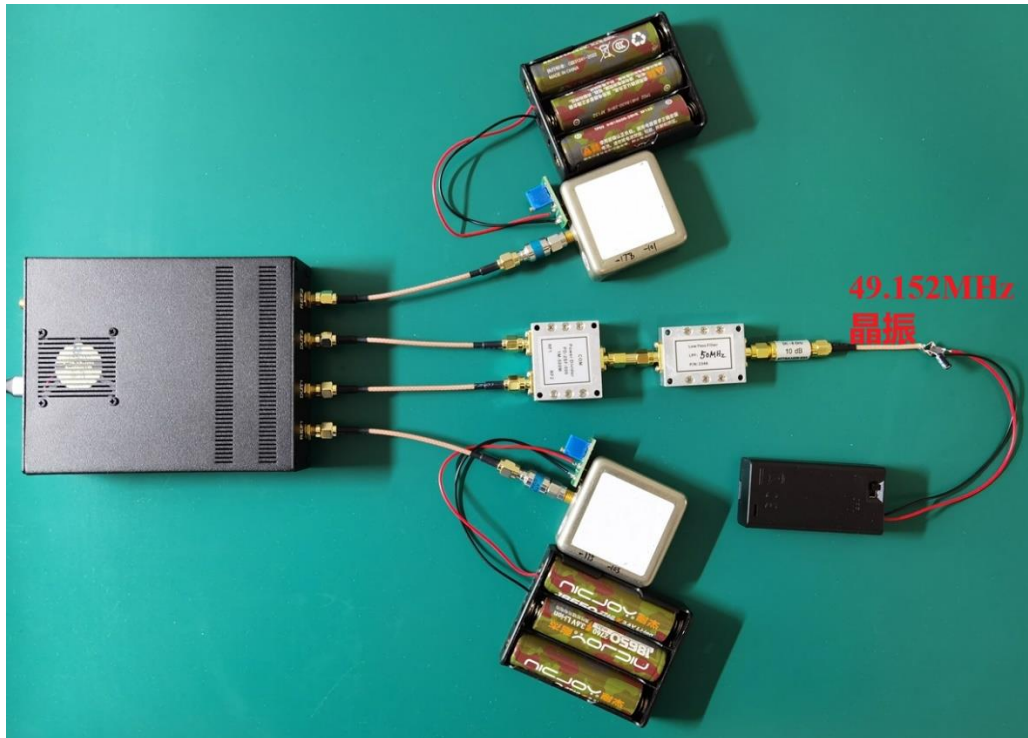

Comparison with E5052:

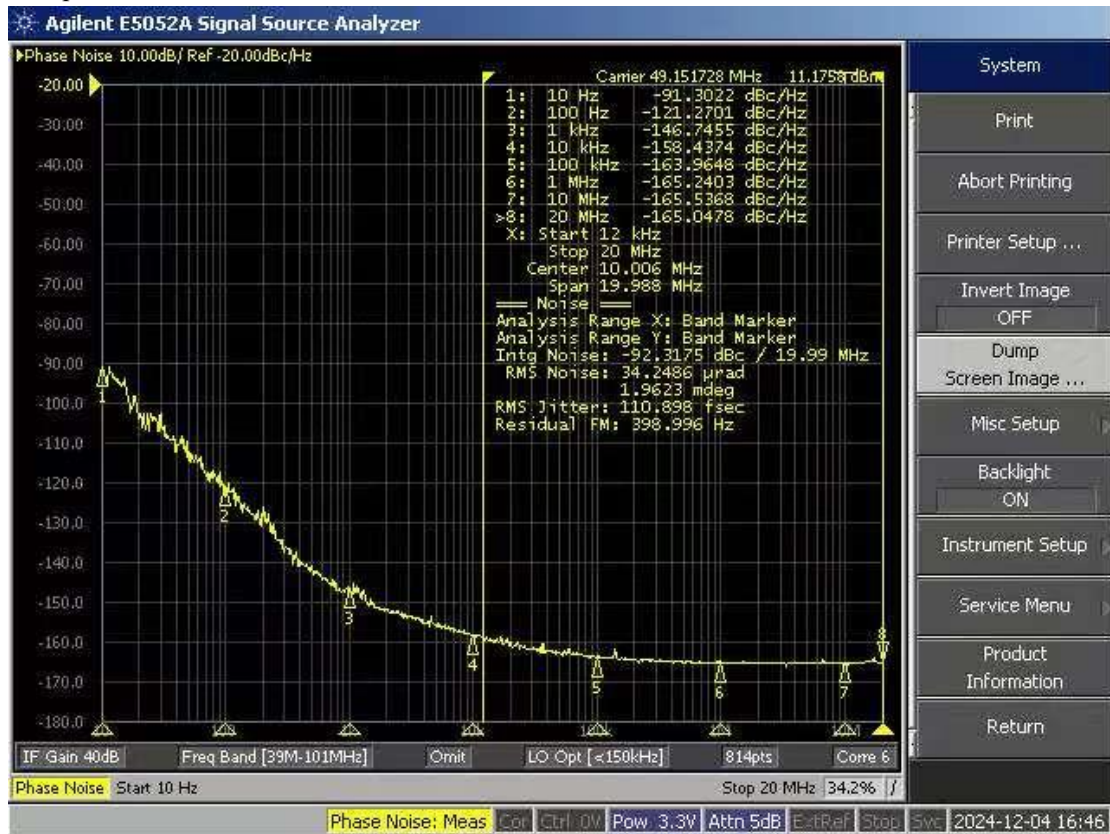

**Caution:**

Incorrect test setup and erroneous results:

If the two capacitors, as shown in the diagram, are removed, the test results will exhibit significant errors.

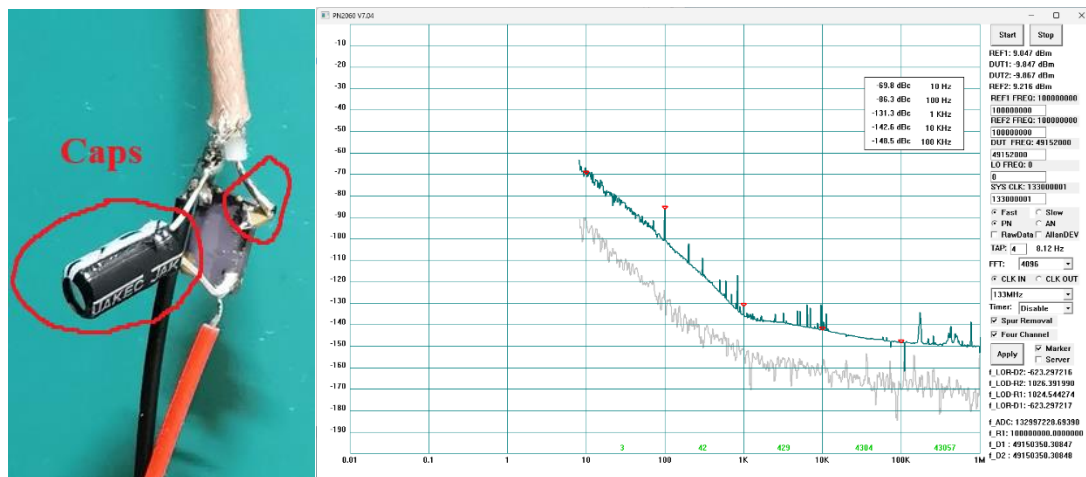

Capacitor filtering: Crucial for certain crystal oscillators.

If the supply voltage is insufficient (e.g., 3.1V from a battery), the phase noise at the far end may degrade slightly.

## Appendix 6: Measurement Failures for Poor Isolation and Impedence Mismatch

- 1) As a digital phase noise analyzer, artifacts can be occurred. All the phenomenon reported in [1] can be reproduced with some specific power splitters (3dB/6dB/10dB/active) & filters & attenuators & specific OCXOs. Strange behaviors will be resulted from impedance mismatch & poor isolation & aliasing frequencies. Solution: Series an attenuator, such as 6dB to improve impedance mismatch, and mini-circuits SLP-50+ (Nyquist Filter) can be used to remove aliasing frequencies. Isolation AMPs should be adopted for some OCXOs with poor isolation.
- 2) Some OCXOs have **poor isolation**, such as part of the old DATUM 2750013-1 models (not all of them). This can result in significant deviations during measurement. Therefore, **the use of isolation amplifiers or attenuators is essential** for accurate results. Following is a comparison with/without 6dB attenuator.

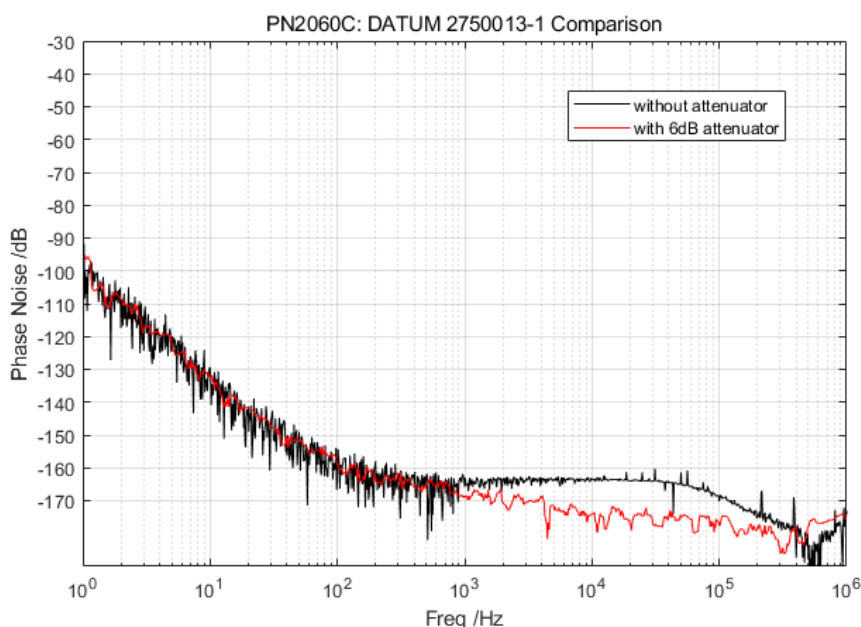
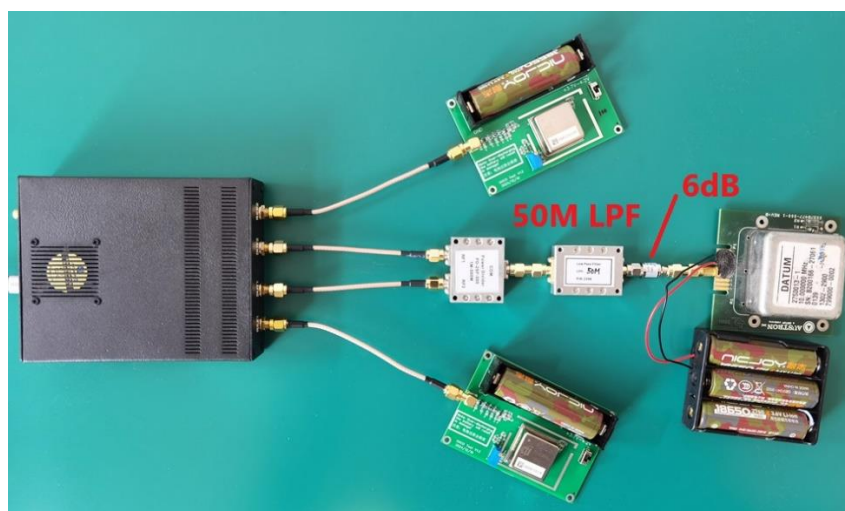

[1] Y. Gruson, A. Rus, U. L. Rohde, A. Roth, and E. Rubiola, "Artifacts and errors in cross-spectrum phase noise measurements," *Metrologia*, vol. 57, no. 5, pp. Art. no. 055 010 p. 1–12, Oct. 2020, open access.

## Appendix 7: Comparison with 53100A

A 53100A is used to measure the 10M OCXO for 10 minutes, and the PN2060C measures it for about 5 minutes. The results are nearly identical.

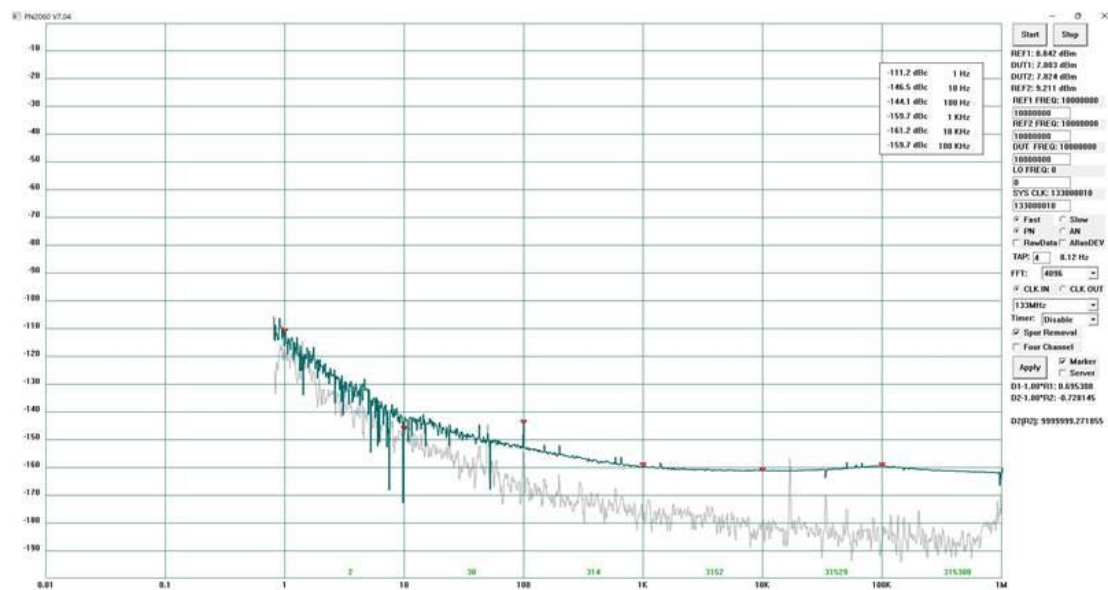
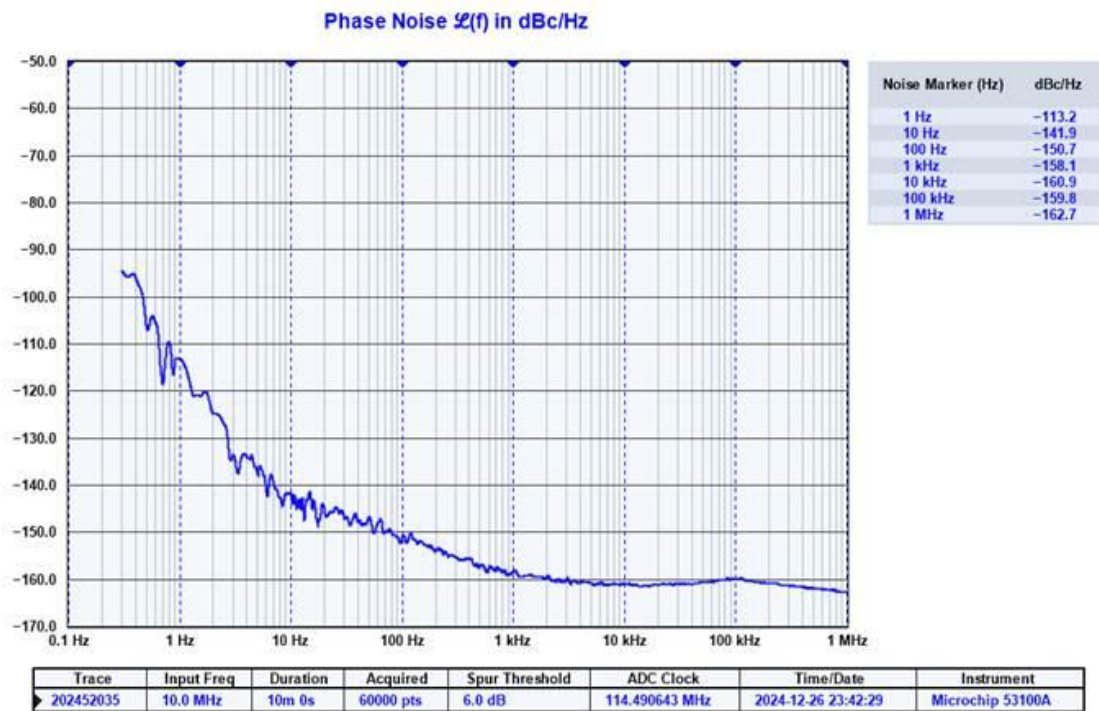

## Appendix 8: Warning for the LPF-50M filter

When measuring very high performance DUTs, the low-pass-filter will be very critical. Following is an example when measuring SCTF 45.152M XO's with very low phase noise,  $-164\text{dBc}@1\text{KHz}$ . It is verified by a E5052A.



The following measurement is completed with mini-circuits SLP-50, which can make a correct measurement at 1KHz deviation.

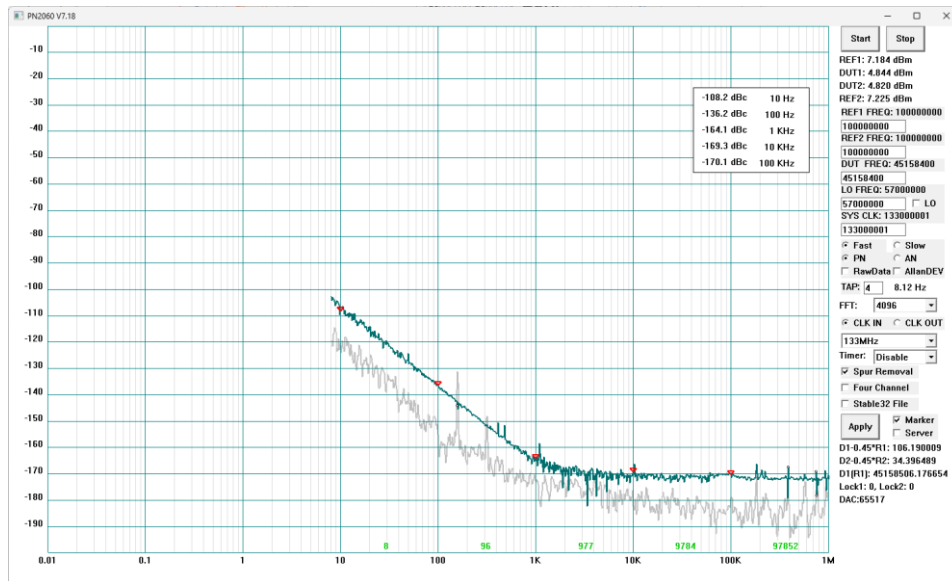

The following measurement is completed with LPF:50M (**old design**), significant deviation will be occurred at 1KHz deviation. **With the new designed LPF, this issue has been resolved!**

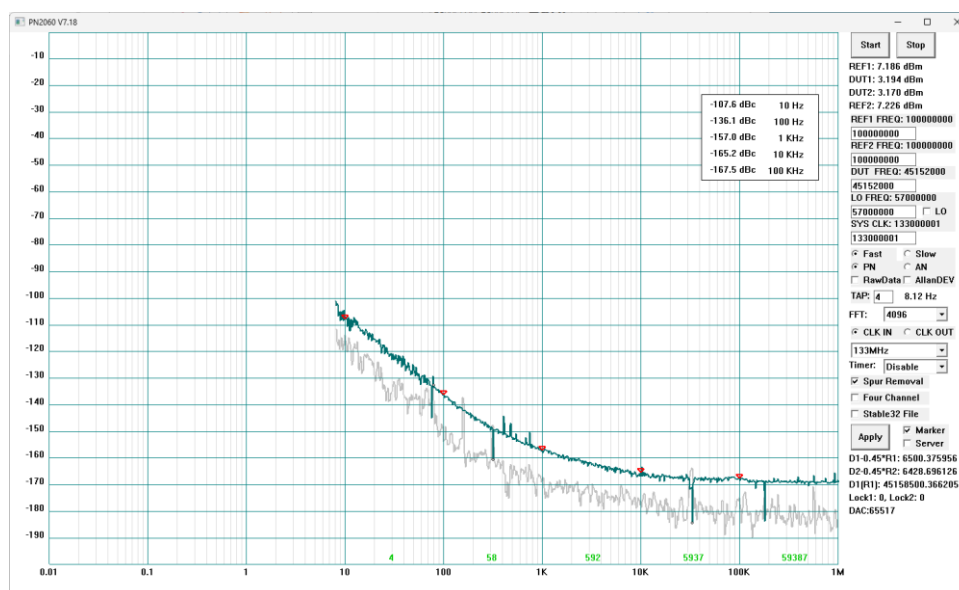

## Appendix 9: PN2060D 50M-7G Phase Noise Analyzer

### Features:

All-in-one solution

Two-channel dual down-converters insides

Two internal references

Two frequencies band supported (1M-50M, 50M-7G)

Phase-locked design (Spurs are greatly suppressed)



### Specification:

item	parameters	notes
frequency range	50MHz-7GHz	1M-50M can also be supported
input power level	<=13dBm	*<=10dBm is preferred*
freq deviation	0.01Hz-1MHz	
Internal REFs	two 102.4M OCXOs	
Signal types	sinwave	
input impedance	50	
Capability	Phase Noise / Amplitude Noise	*AN need further development*
OS support	win7/win8/win10/win11	
size	265mm x 260mm x70mm	
weight	3.5KG	
PC connection	USB3.0 Type-C	
Power supply	+7.5V/3A	*220V to 7.5V power supply included*

deviation	100MHz Carrier (30 minutes)	1GHz Carrier (30 minutes)
10Hz	-125dBc	-100dBc
100Hz	-145dBc	-130dBc
1KHz	-160dBc	-145dBc
10KHz	-170dBc	-160dBc
>100KHz	-178dBc	-165dBc

Measurement example for NEL 1G OCXO (with new designed phase-locked method), where nearly all the instrument generated spurs are disappeared.

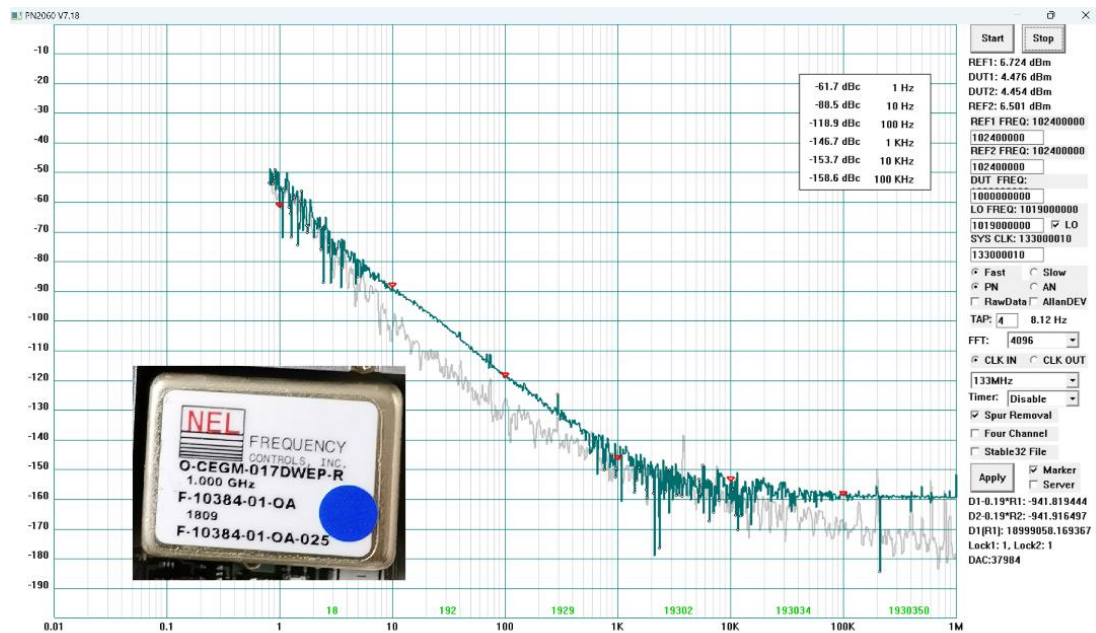

3.8G DRO example (with the file manage tools)

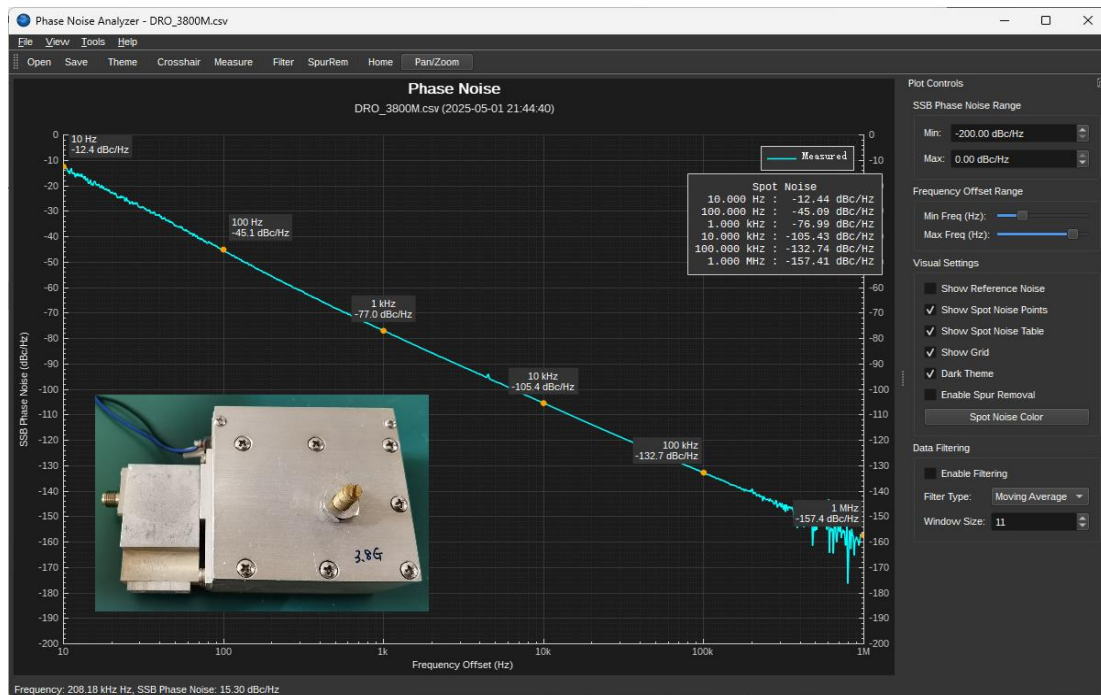

The front panel features a signal input port with a maximum input power not exceeding 13 dBm. The rear panel includes a data port for connection to a computer via a Type-C cable and a power port rated at +7.5V/3A, with the unit consuming approximately 20W after warm-up. Utilizing a higher-performance power supply can enhance spurious suppression, as measurements demonstrate reduced spurious signals on the resulting curve. The structure of the PN2060D is as

following.

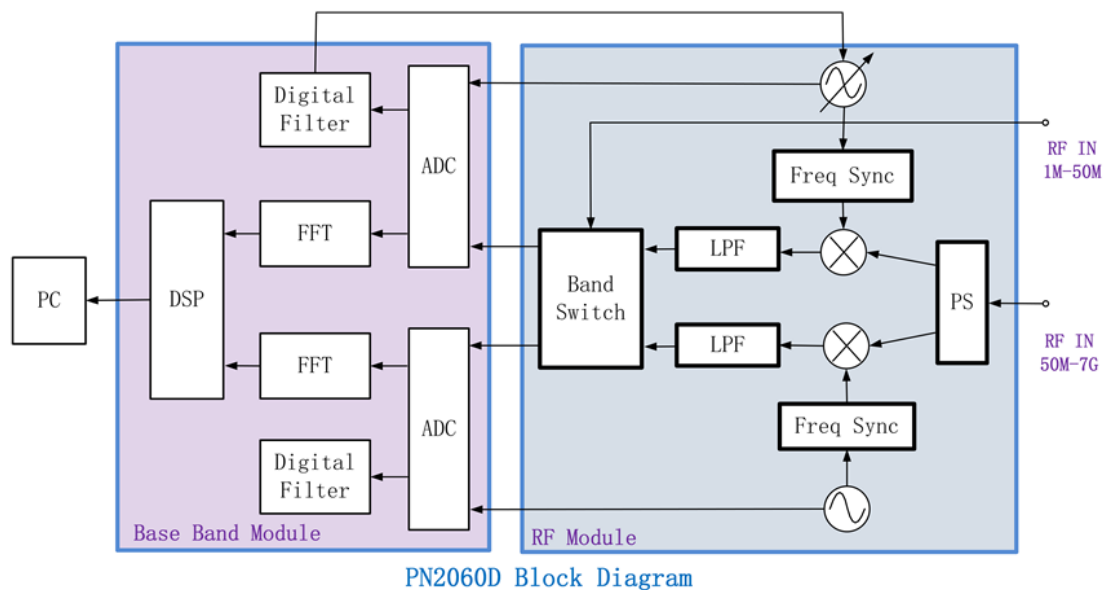

**Usage Instructions:** The fundamental functionality remains consistent with the PN2060C. Please note the following key distinctions: The PN2060D utilizes a frequency-converting receiver principle.

- 1) The **LO** checkbox switches the active **Test Port** frequency band: when **LO** is unchecked, **1 MHz–50 MHz** is selected; when checked, **50 MHz–7 GHz** is selected. All UI changes take effect after you click **Apply**.
- 2) For 50M-7G, during testing, you must select the "LO" checkbox and manually specify the LO

frequency. The principle for specifying the LO frequency is: Set the LO frequency 11 MHz to 25 MHz higher than the frequency of the Device Under Test (DUT). The specific offset within this range can be chosen based on the DUT's quality: For high-performance OCXOs (Oven-Controlled Crystal Oscillators), an offset of 11 MHz to 20 MHz is sufficient; for low-performance synthesized signal sources, use an offset of 15 MHz to 23 MHz. Always maintain the REF1 & REF2 settings at **102400000**. **Crucially:** The frequency offset (difference) should not be too small! A larger offset helps minimize measurement errors at remote offsets; however, **do not exceed 25 MHz!**

**Note1:** Different LO frequencies will produce different spurious components. During testing, selecting an LO frequency that is not an easy integer multiple of the signal frequency generally helps reduce spurs. The interface displays Lock1 and Lock2 indicators: A display of 1 indicates proper phase lock, while 0 indicates an abnormal/unlocked state.

**Note2:** Maintain the interface readings for DUT1 and DUT2 below 6 dBm whenever possible, as this helps reduce spurs and distortion. Specifically, ensure input signals remain below 10 dBm.

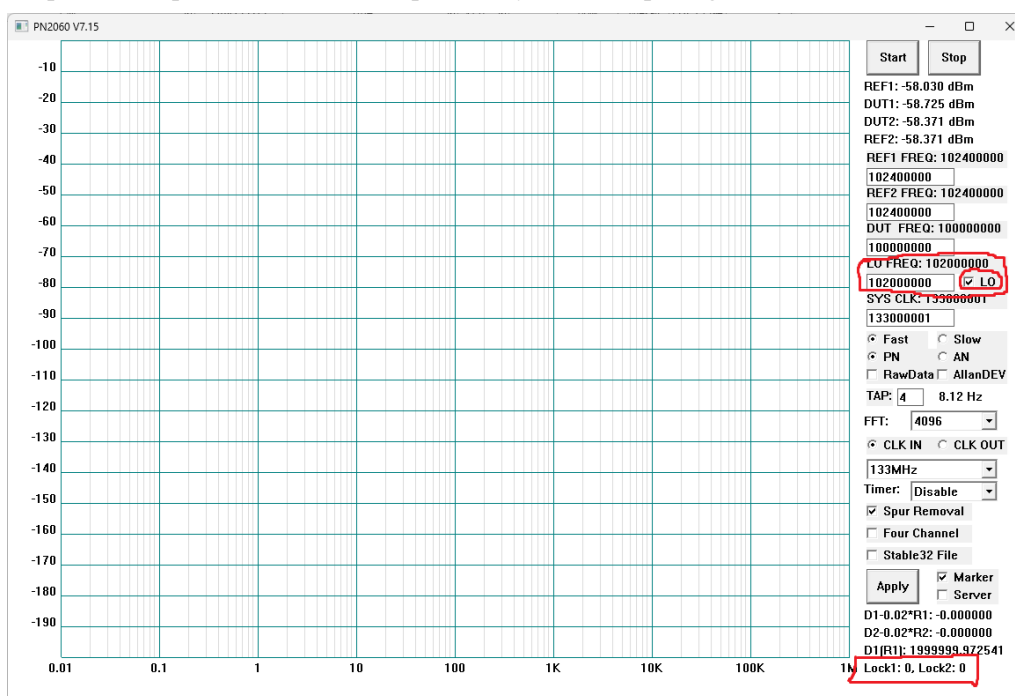

### Digital Phase-Locking Function Description:

The frequency difference between **DUT1 and REF1**, as well as between **DUT2 and REF2**, will converge after digital phase-locking, as illustrated in the figure below. When altering the frequency of the device under test (DUT), a re-locking process occurs. This process requires a certain duration—**ranging from tens of seconds to several minutes**—and **must be continuously monitored**. Test results are valid **only after phase locking is complete**. Future optimizations to the algorithm will accelerate the locking speed. The figure below demonstrates a test case for a 100MHz OCXO, showing virtually no observable spurs.

**Note:** Under certain circumstances, an occasional bug preventing phase-locking may occur. Close the software, delete the **pninit.bin** file in the directory, and restart the software.

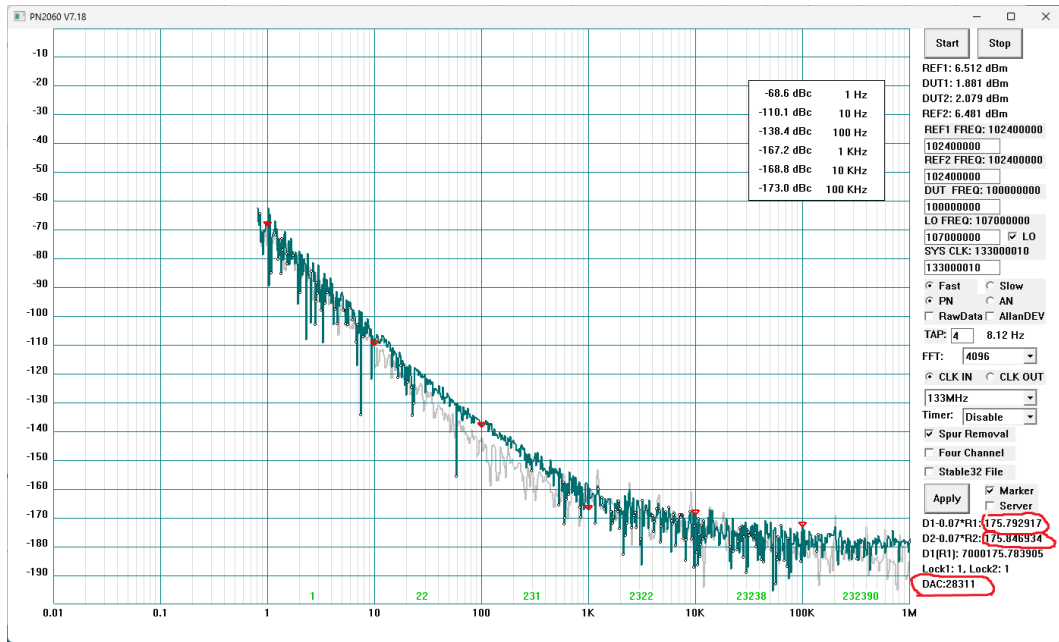

**After completing testing:** Use the "Save File" menu to finalize file saving. This will automatically generate a file in .PNP format.

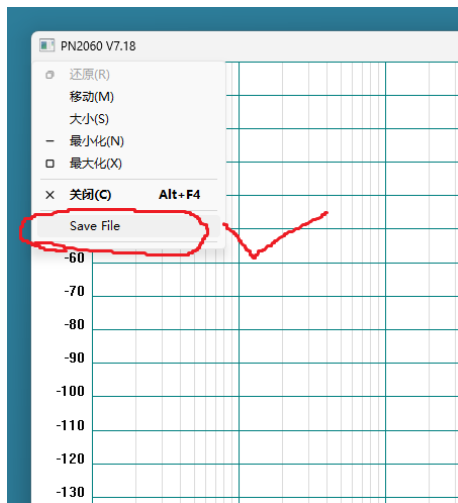

3) **Auto Tune:** Downstream traffic can interfere with data uploading. After warm-up, you can switch **Auto Tune** off to improve stability during long-term operation.