

PACKET STATUS REGISTER

September 1984
Number 12

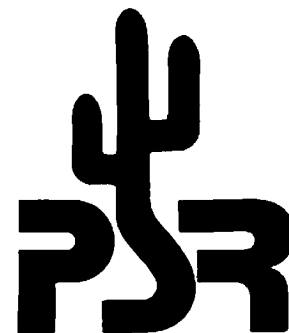

Tucson Amateur Packet Radio Corp.

NOMINATIONS

"Packet Radio Overview and Prospective" will be the subject of the December 2nd North American Teleconference Radio Net (TRN). This net, heard on over 150 gateway stations (mostly VHF repeaters) across the U.S. and Canada and on the OSCAR 10 satellite, will explain what packet radio is, describe how to get started in it, point out the benefits to you, and outline the pitfalls to be avoided for both the novice and expert alike. The speakers on this TRN will be none other than Lyle Johnson, WA7GXD, and Harold Price, NK6K.

Lyle is President of the Tucson Amateur Packet Radio Society (TAPR) and was the primary developer of the TAPR terminal node controller (TNC) hardware. For his work in developing the TAPR TNC, Lyle was awarded the 1984 Technical Excellence Award at Dayton. Looking to the future, Lyle is responsible for the processor design for the upcoming amateur packet satellite (PACSAT). He became active in packet radio in 1981, the pioneer days for this new technology.

Harold is a Director of TAPR and was on the team that designed the software for the TAPR TNC. He is also the AMSAT Project Manager for PACSAT. Harold is another packet radio pioneer, having first become active in that technology in 1982.

Packet radio offers opportunities for both the traditional communicator and for the experimenter. Learn about packet radio from two of its leading developers by tuning into TRN, Sunday, December 2, 1984, at 6:00 p.m. CST (that's 0000Z). For a complete list of gateway station locations and frequencies write the TRN Manager, c/o Midway Amateur Radio Club, P.O. Box 1231, Kearney, NE 68847-1231 (S.A.S.E. please, Canada excepted) or check the CompuServe "Hamnet" XA4 Database.

.....

The FCC has assigned an RM number to a petition to allocate 216-222 mhz (including of course the bottom 2 mhz of the amateur band) to land mobile. This confirms speculation based on Robert Foosaner's (FCC Private Radio Bureau Chief) comments at the ARRL National Convention.

Needless to say, this is a grave development. We NEED that spectrum, particularly for packet radio linking. There is nowhere else to go for the high speed FSK links that are being built right now. In particular, amateur satellite gateway stations NEED 220 mhz as all current and future satellites use all of the other VHF/UHF bands and the gateways have to operate in full duplex.

It is becoming pretty clear that this attack is at least partially based on the rejection of the no-code: the FCC considered no-code to be the amateur's "last chance" to populate the bottom part of the band. It is quite ironic that the ones who get hurt by this proposed change (the technically oriented packeteers) are mostly the ones who argued FOR a no-code license to increase technical experimentation.

The Tucson Amateur Packet Radio Corporation is overseen by a Board of Directors elected by the membership. Currently, there are fifteen Directors, each of whom serves for a three year term. The terms are staggered so 1/3 of all Directors, or five in the present case, are elected every year. This lends long term stability to the organization while allowing the members to have a direct effect on the affairs of the corporation by their annual vote. The actual elections take place during the Annual Meeting held in Tucson every February.

Nominations are now open for the five slots that must be filled this coming February. The procedure is quite simple. Either you, or someone you can convince, submits your name for consideration. If someone else does it for you, you will be contacted and asked for a brief description of yourself for publication in PSR. You will also be given the opportunity to withdraw your name from consideration.

We expect to publish the names and qualifications of all candidates for Director in the next PSR. In addition, the issue will also contain a ballot for you to select five names and mail in, or bring with you to the annual meeting when the votes will be tallied and the results of the election announced. Following the meeting, the new Board of Directors will meet and elect the Officers of the Corporation who will then serve for one year term. Simple, eh?

Directors are expected to play an active role in TAPR by advising the Officers, expressing their opinions on the issues we face and generally helping to see that TAPR continues to be the leading organization and motivating force in packet radio by its research, development and information dissemination efforts.

Please consider this matter carefully and place your nominations now. If you know the person you are nominating (and don't nominate them if you don't), please include a short description of the nominee. Time is very short for this if the information is to be included in the next PSR so

DO IT TODAY!

.....

On Monday July 16, 1984 at 7:45 AM PDT, Curtis, N6ECT transmitted packets to 50 states and half the world, all at the same time!

Serious packeteers might wonder how this feat was done, so here is the scoop. N6ECT was interviewed by the CBS Morning News show as part of a piece done on the Haight/Ashbury 20 years later. As the interviewer introduced Curtis, they focused on some 2300Mhz antennas near his home, and then on his ICOM 211 and CRT, just as he was transmitting packets through the KA6M-2 repeater. A packet burst was heard loud and clear right before they asked him their first question.

President's Corner

by Lyle Johnson, WA7GXD

There is plenty of excitement in Tucson this month! TAPR now has an office, a warehouse, a telephone and an office manager!

The volunteer corps was rapidly decaying into a volunteer corpse -- mail has run as high as 87 pieces in one trip to the PO box, five different people were assisting with membership services and other mailbox-related activities, organization was difficult and... you get the picture.

In addition to the sheer person-power and inefficiencies of having things scattered across town (Tucson is 1/2 million people and hundreds of square miles large), storage space at folks' homes was being usurped in alarming proportions. Something had to be done.

After consultation with the TAPR Board of Directors (your elected representatives), your Secretary and President began to search for office space -- and an office person to offload the burden of day-to-day administration of TAPR.

I am extremely pleased to report that these efforts have been successful. Elsewhere in this PSR you will find the telephone number. The pleasant voice on the other end of the line will (usually) be Karen Makus, your office manager.

So much for what the office will do for your volunteer staff. What will it do for you?

Within a couple of months (more or less, depending on how the transition and training period progresses, the new database management system integrates, etc.), you should see that membership renewal reminders are sent in a timely manner. This should help you keep your membership current.

Kit orders should ship within two working days. We are planning on daily UPS pickup service with a reasonable inventory of TNCs for immediate delivery.

Parts orders, for both mod kits and replacement usage, should likewise ship in two working days.

We will be able to accept telephone orders for kits/parts/membership along with VISA/MasterCard payment service (at a 3% surcharge -- this is what they charge us).

Inquiries via mail should get immediate response to general questions -- however, Karen is NOT a technical guru, so volunteers will have to answer your technical questions, meaning 4 to 6 weeks for a reply.

What other benefits may accrue? With the offloading of the day-to-day affairs of TAPR, some of your more technically inclined volunteer staff based in Tucson may find more time to get on with pa-ket radio!

This is not to imply that there is nothing happening now, nor that Tucson is where it all happens.

For example, Steve Goode, K9NG, has been quietly working on a 9600 bps TNC-to-antenna "modem" and is now testing the design. With a bit of luck, we should be verifying his results and getting ready to find a means to get it in your hands after a bit of testing. So, high speed modems are in progress.

On another front, the powerful TiNC LiNC -- a black box designed to handle multiple protocols (AX.25 Level Two, RTTY, AMTOR -- maybe even CW!) on different channels SIMULTANEOUSLY, and at high speeds (maybe 56 kilobits per second!) is in final "alpha" design. Before year's end we should have several units operational and than... but I suppose I had better not let the whole cat out of the bag! Incidentally, this design is based in San Diego (responsibility for primary hardware design lies with Mike Brock, WB6HHV and a TAPR Director), with hardware design review assistance from TAPR packeteers in Arizona, Florida, Illinois, Missouri, Colorado, New Jersey... the list goes on.

I hope you can see from these two examples (yes, there are others, but if I tell them all now, I might run out of material for the next PSR!) that TAPR is not simply a means of disseminating developments from Tucson to the rest of the Amateur packet community; rather, TAPR is a means for packeteers from all over to share ideas, participate in development and cooperate in implementation of packet systems for the benefit of all Amateurs.

One point that I try to stress in my travels is that TAPR is not out to dictate to anyone; we are here to serve everyone and act as a focal point for ideas, a coordinator of efforts if you will. One way this can be brought about more efficiently is if YOU write to us, mark the envelope "For PSR", and let us know what is going on in your area. Multifrequency digipeaters, how many folks are on in what areas, what frequencies are used, what BBS systems are up, what programs work with the TNC on what computers, how you solved the why-the-TNC-goes-in-the-woods-when-300-volts-is-applied -- you get the idea. We want to help you share your packet experiences with others. Please write...

★★★★★★

David Henderson, KD4NL, one of the authors of the software running on your TAPR TNC, has rewritten the Pascal code for the TAPR TNC to run on an IBM PC (or clone). Dave's code duplicates the TNC environment: the command structure, the monitor mode, etc. on the PC and runs a simulated HDLC/radio link. Operationally, you "connect" to yourself, then watch what's happening via monitor mode, play with link timings, etc.

One major goal the software package addresses is that of protocol development and experimentation. If you want to try changing the code for various enhancements, or just better understand how your TNC works -- and if you have an IBM PC -- this package may be just what you have been looking for.

System requirements are: IBM PC (or clone), 192k bytes RAM, FC DOS 2.0, IBM PC Pascal. Send a stamped, self-addressed diskette mailer, with formatted DS/DD system diskette to:

Adroit Software Products
2210 Wilshire Blvd, Suite 773
Santa Monica CA 90403
ATTN: AX25 Software

This is a "user-supported" experiment, meaning that you can copy and distribute the code as you wish. If you find it of use, a suggested contribution is requested. Contact Adroit Software for further information.

Packeting In The Fast Lane

by Lyle Johnson, WA7GXD

"Hmmm. Why is it that I haven't heard from anyone using the high-speed clock option on the TNC?" I mused to myself one summer day. "Come to think of it, why haven't I heard from me!"

With that, I rushed to the laboratory (the lair of bearded fanatics...) and grabbed the 'scope, counter, terminal and TNC.

Step one was to verify the operation of the TNC. This was done using the famous WA7GXD analog loopback mode (a piece of wire from radio I/O connector J3 pin 3 to J3 pin 5 -- works great since the TAPR TNC is a full-duplex machine!). I connected to myself via myself as eight digipeaters, then sent beacons the same way.

Satisfied that all was working well, I consulted the TNC schematic and removed the jumpers at J5 pins 17-18 and 19-20. I then installed a jumper at J5 pin 17-19. This effected a digital loopback, where the TTL-level transmit data output from the HDLC controller was simply connected to the TTL-level receive data input. I then connected to myself and saw that this mode indeed worked. This is a handy way to isolate the digital circuitry from the modem in case of troubleshooting.

Cautiously, I entered the command mode and set HBaud to 4800. I then connected to myself, digipeated through myself, and did all manner of exercising of the link -- it worked flawlessly!

Pleased with this outcome, I removed power and set the jumper at JP7 to the high-speed side. This means that the system clock runs at 1.8432 MHz and the system timing parameters are all twice as fast as normal (all but the serial port -- it has its own hard-wired tap on the clock circuit so the ABaud rate remains sensible!). I powered it up, and lo! it worked fine! The 1 Mhz chips forgot that they weren't supposed to be the 2 MHz parts, the EPROMs decided to access okay and the peripheral parts just seemed to love it!

At any rate, the CWID was now about 40 WPM (I then disabled it), and the system was running just fine at 9600 baud on the radio link!

After I calmed down, I set the TNC up at the normal clock rate and hooked up an external clock (remove J5 jumpers at pins 11-12 and 13-14, jumper J5 11-13, apply a TTL-level square wave at J5 11-13), and verified that the TNC worked.

The next step was to see where it fell apart, so I kept monitoring a long beacon text sent unproto via myself three times (UNPROTO CQ VIA WA7GXD,WA7GXD,WA7GXD) and cranked up the data rate on the HDLC controller. I set the terminal port to 19,200 Baud just to keep the 6809 busy with output. I even turned trace on to \$FFFF!

The unit kept up quite well at 4800 baud under all of this abuse (there was some delay in between digipeated frames due to all the I/O, but not much). At 9600 baud, the TNC would usually copy the first packet, dump it to the screen, and forget to digipeat. Playing around with the DWAIT, TXDELAY and FRACK parameters didn't help. Varying the frequency of the function generator (and thus, the HBaud rate), I found the TNC would handle things just fine until the data rate got to about 9400 baud -- then it would get the first packet, but wouldn't digipeat it. If I turned trace back on to \$FFFF, the top limit dropped slightly to about 9100 baud, and the delay between digipeats extended considerably. Of course, that most digipeaters don't have trace on \$FFFF: that adds a tremendous load on the I/O system!

I also found that, if I left a Control-S on the line (XOFF - tells the TNC to not send data to the terminal port), the TNC would happily digipeat all three times at 9600 baud - it worked okay past 10,000 baud but never copied a packet by the time I reached 11,000 baud. The XOFF trick doesn't do much good if TRACE is left at \$FFFF, so I set it back to the default (\$1000).

If I watched the LEDs, and sent a Control-Q (XON - tells the TNC to go ahead and ship data to the terminal port) after the digipeats were completed, all four monitored frames were in the buffer waiting for me.

I repeated the experiments at the double clock speed and found the TNC was quite happy to do a multiple digipeat at over 20 kilobaud with terminal I/O at 19.2 kilobaud -- it just kept on playing as long as I cared to watch it.

The net result? We have a (nearly) 9600 baud TNC with the normal clock rate and a better than 19,200 baud TNC at double the normal clock rate -- using standard parts!

I would be interested in hearing from as many of you as possible as to whether your TNC works okay with the double speed clock (if you put it on the air, use HBaud of 600: this will be 1200 actual, and be sure to use double the normal parameters for DWAIT, TXDELAY, FRACK, etc.). A trick way to try the higher data rates on-board in digital loopback (as outlined above) is to use a jumper from R79 to +5 volts (this sets the HDLC controller to an x1 rather than an x32 clock for the radio link) and set HBaud to 150 for 4800 baud equivalent, 300 for 9600 baud equivalent at normal clock speed, and HBaud of 75 for 4800, 150 for 9600 and 300 for 19,200 with the twice-normal clock, so the function generator is not necessary.

★★★★★

The Second Annual AMSAT Technical Symposium and the 1984 Annual Membership Meeting have been firmly scheduled for Saturday 10 November 1984. The specific day was selected following careful consideration of all available individual preference comments.

The location will be the Amfac (formerly Airport Marina) Hotel at the corner of Lincoln and Manchester, on the north side of Los Angeles International Airport (LAX). The address is 8601 Lincoln Blvd., Los Angeles CA 90045. Telephone: (213) 670-8111.

Prices are moderate and major credit cards are accepted. A block of "corporate rate" rooms has been set aside for AMSAT use. Room reservations should be made directly with the hotel.

Facilities Chairman is Dennis Dinga, N6DD. Dennis will be handling arrangements for the planned luncheon and dinner on the day of the meetings. His address is: P. O. Box 4111, Diamond Bar, CA, 91765.

Dr. Cleyon Yowell, AD6P will serve as Symposium Technical Chairman. A call for papers has been issued. Submissions should be sent to Cleyon at:

The Aerospace Corporation
Mail Station M4-930
P. O. Box 92957
Los Angeles, CA 90009
(213) 615-4234.

Software Bug Patch

by Harold Price, NK6K

The following bugs are patched and become version 3.3 of the TAPR TNC software:

(1) RETRY counter is not maintained correctly in all cases. You may get the "retry count exceeded" message when you don't expect it.

(2) An AX25 OFF mode only problem with beacons.

Note: If you always run with retry 0 or have never seen a random disconnect, and if you don't usually run with AX25 off, then don't work up a sweat getting your proms updated. A major maintenance release is in the works which will incorporate these fixes. These patches are being released early by popular demand.

These patches can be applied locally if you have the facilities to read the current prom, edit it, then return it. The patches are to the A000 prom only. The patches are the same for both the BETA version (3 prom set), and the KIT version (4 prom set). The BETA and KIT proms are NOT interchangeable however, so don't get them mixed up.

Address	Current Contents	New Contents
AC99	7F	7E
AC9A	15	AC
AC9B	DB	81
BB74	17	7E
BB75	21	BA
BB76	F2	33

Once changed, the checksums (CAL command, menu option 5) for the A000 PROM will be 4C9F for the Revision 2 kit TNC, and 5D3A for the Beta TNC.

Due to the PSR deadline and other things, we haven't got enough time to document the checksums for all the post 3.1 release patches BETA and KIT. This is one of the reasons why we wanted to avoid patching, but we feel the retry bug is painful enough that here it is. In any case, none of the previous patches has been to the A000 rom, its checksum should be as above regardless of whether you have 3.1 or 3.2. The 3.2 patch added 400 and 800 and other odd baud rates. This was for some AMSAT experimenters and won't be needed by 99.44% of TNC owners. This patch will be needed by a greater number, and becomes version 3.3. TNCs shipped after the patch is applied at the "factory" will have version 3.3 in the signon and beacon text.

The next software maintenance update will probably be called version 3.4. This will be a change to the software and will change all ROMs. Unless we are very lucky and find a tighter compiler, the new software will not fit in 3 ROMs. Beta board owners should not despair, we should release hardware update procedures to get you to four ROMs before the software requires it. (Hint: I've got a Beta board).

On August 23, 1984, Curtis, N6ECT, and Mike, W2FRT, exchanged packets at 9600 bps using quadrature amplitude modulation techniques over a path of five miles. We were both using personal computers, 9600 bps modems, homebrewed radio/modem interfaces, 440 MHz radios, with verticle and beam antennas. The software was written in Turbo Pascal for use with the SDLC cards in the computers. There were no transmission or reception errors and the throughput was 100% at 10 watts, and 60% to 70% at one watt.

★★★★★★

Software Bugs

by Harold Price, NK6K

Since a TAPR software maintenance release will be out soon, I'd like to make sure we have all bug reports and requests for changes in.

I'll list the ones I know about here, along with a disposition, if known. Please feel free to make comments on any part of the TNC, hardware or software. Please keep in mind the following though:

There are now at least 1300 TAPR TNCs (Beta + kit) in the world today. Many people have written code to match the current user interface, mailboxes, bulletin boards, host systems, gateways, etc. Ask yourself if your proposed change will require a change in user software. If your suggestion would cause recoding of other ham's software, unless it has a major benefit, we would probably have to turn it down. This is called the real world, which is something you get into when 1300 hams are involved.

A few of the discussions below will seem long and involved. That is because some of the bugs are in more advanced features. The majority of the bugs in the more common features were wrung out in the beta test. On with the bugs:

(1) If RETRY is not 0, the TNC will sometimes disconnect before the retry count has expired. This problem took a long time to find, because we couldn't reproduce it. Someone in the field came up with a reliable way to make it happen. The symptom was affected by both the number of frames in flight, and the number of frames in the buffer waiting to be sent.

(2) TNC "locks up". This is a difficult symptom to trace. Most of them are caused by a fault in the hardware. We have found a bug in the software that could cause this, to my knowledge only one person has fallen in to this particular hole. This is patched along with the retry bug.

(3) TNC prints garbage on the screen, 64K worth, then comes back. I have heard rumors that the GLB board can send a frame which causes this to occur when it is received by a TAPR TNC. If anyone has firm information on this, please send it in. Sometimes the rumor comes in as "The GLB sends an illegal protocol frame", possibly an I or UI frame with no PID byte. Based on that, and the symptom, we have fixed a problem that would occur if that type of frame was received. If you have any info on this, send it in. This will be fixed in the next software update: it is not patched.

(4) The beacon is not started even if a non zero value for beacon time is stored in NOVRAM. True enough. You must give a BEACON command after every reset. This bug will be fixed in the next software update.

(5) The 400 and 800 baud rates for HBAUD that were there in 2.1 disappeared in 3.1. A patch is available for this, and has been sent to the AMSAT guys who needed it. They use 400 baud PSK thru Oscar 10. Fixed in next software update.

(6) *** connect request comes out in transparent mode. I can't make this happen. It will happen if CONMODE is CONV, you are currently unconnected, and you manually go into transparent mode by saying TRANS. When a connect occurs, you will go into CONVERS mode and will see all messages. If you want to do this, and remain in transparent mode on connect, say CONMODE TRANS. If anyone has another way of making this happen, please let me know.

(continued on page 5)

(continued from page 4)

(7) If your terminal overruns the TNC's input buffer by ignoring an <xoff> character, the TNC will never try to <xoff> you again. Serves you right, too! This bug should be fixed in the next software update. See also improvement #11 below.

(8) TRACE 2xxx bit doesn't work. Non-header data is always dumped.

(9) Autobaud is a bit flakey. Since the hardware has no specific baud rate measuring capability, an easy fix is simply to limit the autobaud choices to 300 and 1200 baud. If this would have caused a great deal of difficulty in getting your board up the first time, please let us know.

This is the end of the known bugs, i.e. those things which work counter to the way we intended, or counter to the way things were documented.

The following are change requests.

(1) Store a line to be transmitted when your TNC is connected to by another TNC. E.g. CTEXT I'M IN THE SHOWER, PLEASE RING BELL. That message would be sent automatically when a connect occurred. This stands a good chance of getting in.

(2) Store a line to be transmitted when your TNC refuses a connect from another TNC. You'd like the other guy to see

*** WB6UUT busy: MAILBOX IS DOWN.

This is a little more iffy. Since the frame used for a connect NAK, DM, has no I field, we have to put the text in a UI frame. The connecting TNC would have to have MON ON, and the UI frame would have to follow the same digipeater path back, which may be a different path than UNPROTO packets usually take. Thus, even if you used this facility, you stand a finite chance of it not working. Is this worth the effort to implement? Comments please.

(3) Link status check. You'd like the TNC to automatically send a frame to see if the other TNC is still there. If not, your TNC would timeout based on RETRY. The command would be CHECK EVERY/AFTER n, where n is a convenient interval. It would not apply if RETRY was 0. This will require a protocol change or update. Right now, with the poll/final controversy, there is no way to prod the other end into giving a response, short of sending a zero length (PID byte only) Iframe. This seems a bit tacky. This is on the list of things to get resolved at the next protocol review in September.

(4) Discard unacknowledged I frames when a disconnect occurs. Currently, if there are outstanding frames, i.e. frames waiting to be ACKed or resent, or frames that are in the terminal input queue but as yet unsent, we dump them as UI frames to the UNPROTO address list. This is listed under improvements because this is as we intended it to be, i.e. this is a feature, not a bug. We feel this is a useful diagnostic aid. WE in this paper, by the way, is various combinations of KV7D, KD4NL, and NK6K, depending on which of us is responsible for that part of the code. Comments on this one, please.

(5) Implement a TNC resident file transfer protocol. When it comes to file transfers, the TNC was designed to be transparent, just like a modem. In fact, if you go into transparent mode, you can run any program that assumes it's talking to a modem and get the desired results. (And no, it doesn't dial the phone on ATDT commands, wise guy). Note that if you want to transfer 8 bit data you must set the AWLEN and PARITY options

correctly, otherwise we'll trash the high order bit. Most data transfer programs will run correctly thru the TNC, as long as their internal timers can handle the inherent delays in packet transmission and digipeating. Implementing a TNC based file transfer protocol would please a small number of users, who would still have to write code on their computer to interface with the TNC's file transfer mechanism. I think the current scheme is the right choice, and is more in line with the division of tasks set out in the ISO seven layered OSI model. Comments?

(6) Confirm entry into CONVERS mode. You want a warm fuzzy feeling that the TNC has done your bidding in response to the CONV command. This would require a change that would bother the mailbox/host/gateway crowd. They do a lot of popping in and out of command mode to check status, paths, and other things. An extra message might put the warm fuzzy message into a file, unless they modified their code. Comments?

(7) Go back into command mode after a disconnect initiated by the other TNC. Currently, you are left in CONVERS or TRANS mode. This should not both mailbox/host types since ctl-C in command mode is ignored. Comments?

(8) Implement a watchdog timer. Have the software pulse a bit on the parallel port at some inner point only reached if the software is running correctly. This is so mountain top digipeaters can reset themselves if something bad happens. Note that this is different than the hardware transmit timer. Good idea, and it will probably be in the next release.

(9) Print the digipeat list when:

- (a) Someone connects to you
- (b) When you get a connect request
- (c) When monitoring the frequency.

I think (a) and (b) should be done all the time. (c) would add to an already cluttered monitor mode. Anybody see a better way of doing it. Adding another command to enable this would add to an already lengthy command list. MPATH has been suggested.

(10) Print connect and disconnect packets in monitor mode. How about:

```
NK6K>WB6YMH <C>
WB6YMH>NK6K <D>
```

There are connect ACK and disconnect ACK frames, but that might be getting carried away.

(11) Increase the number of bytes that the TNC will handle from the terminal after the TNC signals <XOFF>. Currently, you must stop within five bytes. After that, the TNC sends another <XOFF> after each of the following five bytes. After that, any characters received before the TNC sends an <XON> are discarded. While this has not been a problem for users writing file dumpers in assembler or some high level languages, it has been a problem for programs which dump a line, then look in their input buffer for <XOFF>. We will probably increase the guard space to at least 80 characters. Anyone need more?

(12) Output <CR> after the callsigns on monitor lines. This would give more room for digipeat paths and not break up data lines.

(13) Echoing XOFF and XON. Currently, if the terminal sends a flow control character out of sequence (XON before XOFF, 2 XOFFs in a row, etc.), the TNC treats such characters as data and echos them. This has the effect of locking some terminals. It has been suggested that we eliminate this feature and ignore those characters.

(continued on page 24)

VADCG Upgrade

by Terry Fox, WB4JFI

The Amateur Radio Research and Development Corporation (AMRAD), originators of the popular AX.25 packet radio protocol, has developed a retrofit board for the Vancouver Terminal Node Controller board, originally developed by Douglas Lockhart, VE7APU. Using the daughter board (part number VDS-1), systems designers are now freed from the memory constraints of the original board. This translates into better operation for the packet radio enthusiast.

Some of the advantages of the AMRAD Vancouver Daughter board system are:

- * No modifications (jumpers or traces cut) required on the Vancouver board for normal operation.
- * No jumper wires to hook between the two boards (All connections necessary are done via wire-wrap sockets).
- * EPROM is expanded from 8K to 32K.
- * RAM is expanded from 8K to 32K.
- * Software programmable baud rate generator (using Intel 8253).
- * Optional use of timed interrupts for better software control.
- * Up to six 16-pin sockets, one 24-pin socket, and an are of 1.1 by 1.7 tenth-inch holes for user kludging.
- * Uses only two additional IC's (other than RAM and EPROM).
- * Requires no additional power supplies (the minus five volt supply needed for the 2708's can be eliminated)
- * Full documentation available.

To order a VDS-1 board, send \$25.00 plus \$2.25 for shipping (US funds) to:

Technetronics Systems Inc.
ATTN: Charles O. Phillips
6134 Columbia Pike
Falls Church, VA 22041

★★★★★★

UOSAT-2 ground controllers at the University of Surrey switched on the VITA/AMSAT Digital Communications Experiment for the first time on Tuesday, June 5, 1984. Current drain is within the range expected. The first major operational test of the DCE was also carried out successfully when the DCE was given control of the downlink beacon. Indications were that the ROM based bootloader was active and awaiting software load commands from the ground. The first software tests are scheduled for tomorrow. These tests will check out a portion of the DCE's 128K bytes of memory as well as testing its data transfer functions.

We know the bootloader is working because it occasionally sends a series of 'N' characters on the downlink. This means it is running, can talk to the downlink, and is seeing characters on the uplink. Since the N's aren't steady, it means the input is not locked at the same character. The bootloader prints N's when the one byte preamble is not followed by correct frame headers, data, and checksums.

RS-232 Problems

by Lyle Johnson, WA7GXD

It has come to my attention that the TAPR TNC's hardware flow control scheme has a big problem.

If ICTS is negated (tell the TNC to stop sending data to the user port), the 6551 UART may halt in mid-character. This could cause loss of a character so carefully protected by the FCS, having hazarded its way to your QTH by a difficult and dangerous, and perhaps non-Level-Two, multip-hop path (sigh).

This is not good. In fact, some folks' BBS's and other automated operations find it to be very bad indeed.

The Synertek data books are very vague about this, but seem to indicate that this is a feature, not a bug.

The Rockwell Data Book (July, 1981) has a timing diagram that confirms that the aforementioned behavior is in fact a feature.

However, the latest Rockwell Data Book (Synertek is still vague, and Commodore now uses the software approach in their Vic-20 and C-64 machines), 2nd Edition, 1984, clearly and specifically shows a timing diagram that indicates the "feature" has been changed!

New versions of the Rockwell R6551P properly implement ICTS flow control by completing the current transmitted character before going into the "BREAK" condition, so you don't have to bit-synchronize the handshake with your "host".

I am checking with Rockwell to find the date code for the chips that implement this change (does this imply the previously documented feature was in fact a bug?) and TAPR will arrange to get a few of these chips for field testing.

If they work as newly documented, a simple substitution is all that will be needed to make the hardware handshaking become civilized...

Stay tuned... (whew! maybe we really did implement RS-232C correctly!!!!)

★★★★★★

If you read the editorial by Dave Sumner in your June QST, then you know that the ARRL is going to be putting some effort toward supporting the growth of packet radio. In part, we have Paul Rinaldo to thank for this. The ARRL Technical Department (of which Paul is the manager) will be addressing many of the needs of the packet network. In order to complete any projects, they need to set some priorities, and in order to set the priorities, they need to know what people in the field are already doing.

The ARRL would like to begin work on a spectrally efficient high speed (9.6 or 56 kb) modem. If you are already working on such a modem, send Jeff Ward, KBKA, a message DETAILING your efforts. In conjunction with the modem design project, we will be working on RF strips for the high speed back-bone.

Also, the ARRL would like to find out if anyone is working on audio baseband 9.6 kb modems. These modems exist for phone service, but it is unknown if the average 2-meter rig can handle it.

Let the ARRL know what you are working on, and what you think they should be working on. And finally, send them any comments you might have on the proposed national packet directory.

Crossband Digipeater

by Mike Brock, WB6HHV

The need to tie packet frequencies in different bands together came up a while back in the San Diego area and the solution to this problem may be useful to other packet LANs around the country. The problem is that (believe it or not) not everyone has a two meter radio that they can use for packet. And then how many times have you heard questions to the effect of "Why don't we use 220?" and the associated comments which are "I'm on 220 but nobody else is up there". These problem can be solved in a rather simple and inexpensive way. Later on I'll suggest some other uses for the crossband digipeater.

The idea, as previously mentioned is very simple and easy to implement. What you do is to effectively parallel two radios on one slightly modified TNC. That's all there is to it. The audio lines from the radios are combined in an op amp mixer and then fed to the TNC. In order to minimize the parts required I just adjusted the audio output level of the TNC to the setting required by the radio that needed the most drive and then ran a pot across the TNC output to set the level required for the second radio. For the second PTT line I just added a transistor (junk box 2N2222) and drove that off of the 555 fail safe timer (the same place the PTT buffers on the Beta TNC are driven from). You can put a VFET here if your radio requires one, but my radio didn't need absolute ground to key it and I didn't have a VFET in my junk box. I wired this circuitry up in the wire wrap area of the Beta TNC I used for this experiment. I used a ten pin connector to interface to the radio since this is the type of connector used for that purpose on the Beta TNCs. Now with the exception of the audio output level, I can use either radio on either connector.

How does all of this work? It works rather well. The users of this special digipeater don't see any difference between it and a standard digipeater. To connect to a station on the other band he just types something like

CONNECT WB6CYT VIA WB6HHV-2

where WB6CYT is on the other band (or not, it really doesn't matter) and WB6HHV-2 is the crossband digipeater. When the digipeater sees its call sign in the repeat field, it will retransmit the packet on both bands. When WB6CYT acknowledges the packet, that acknowledgement is

also retransmitted on both bands. The only real difference the user will notice is that even if the ham he is talking to is next door, he will not hear him directly. This also means that this digipeater is susceptible to collisions at its input. This is the same digipeater problem that occurs when there are users that can't hear each other but a normal digipeater can hear both. The crossband digipeater is actually a little worse since this collision problem will occur with local stations who are on opposite bands as well as the typical distant station problem. Fortunately, most of these problems will vanish with the introduction of level three as will the need for this type of device.

One of the benefits of this scheme is that it allows two nets to occupy the same geographical area and yet not interfere with each other until someone specifically requests the cross connection. This can be very useful in areas where there is a lot of packet activity. This digipeater provides a cheap and dirty way to have two frequencies and yet makes it possible to talk with people on either band without having to have two radios/TNCs or to be constantly switching back and forth to find the people you want to talk to.

Another one of the benefits is that a pair of these digipeaters can be used to form the basis of a temporary inter-LAN link. It is temporary because this will all be replaced by level 3 implementations. This scheme makes use of the multiple digipeat extension to AX.25. The user would connect to the remote user by entering a command similar to the following

CONNECT NK6K VIA WB6HHV-2,WB6YMH-1

assuming that HHV and YMH are the crossband digipeaters. The reason for using an alternate band for the link is to allow access to the adjacent LANs standard operating frequency. In Southern California we are moving to a plan where San Diego is on 144.760MHz and L.A. is on 145.360MHz because of the level of activity. The problem with everyone being on the same frequency is that there are stations that can hear both LANs and that tends to increase the collisions and therefore reduce the efficiency of the network. Splitting the LANs eliminates this problem but means that you can't talk with the hams in L.A. any more. The crossband digipeater reestablishes the L.A. connection but only on demand.

Audio Circuits

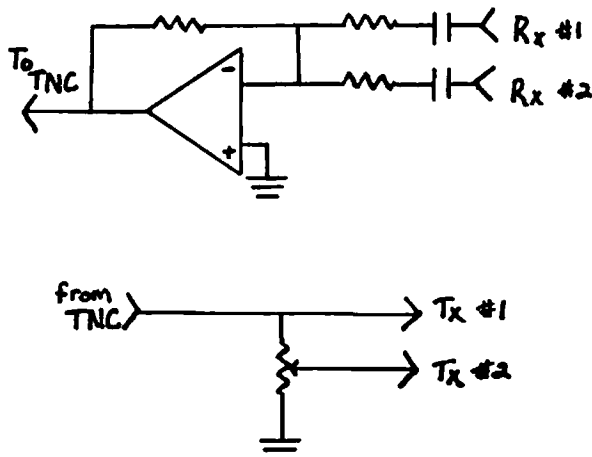

PTT Circuit

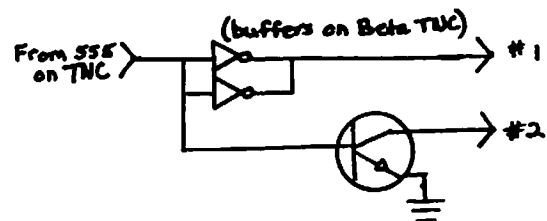

Meteor Scatter Connections

by Richard Zwirko, K1HTV

The Perseids is one of the best of the numerous meteor showers which occur throughout the year. Although this shower usually peaks around August 11th or 12th, many contacts are made via the ionized trails of these meteors a number of days before and after the peak. At 2 Meters, the duration of meteor bursts can run from milliseconds to a few minutes. Most of the early VHF meteor scatter (M/S) work on VHF was done on 144 MHz using CW as the mode of communications at speeds of 15 TO 35 WPM. As single sideband equipment became available on 2 Meters many contacts were made via meteor scatter via that mode. Voice speeds range from 250 to 350 WPM. A greater signal to noise ratio is needed for SSB, probably between 4 and 6 DB more.

Two Meter SSB meteor scatter contacts have been made by many stations 1000 miles apart running no more than 100 watts to a 10 DB gain yagi antenna. Since the transmission data rate of SSB is approximately 10 to 15 times faster than CW, a complete two way SSB contact can be made on meteor burnout which lasts from 10 to 15 seconds. Since most M/S calling sequences used by 2 Meter stations are 15 seconds long, it is possible to get a fifteen second long meteor burst and still not make a contact. The problem is to catch the meteor at the right time.

Now along comes Packet Radio with its 1200 baud transmissions. At 8 bits per character (letter), data is being sent at a rate of approximately 150 characters (30 WORDS) per second. That's about 1800 WORDS per minute or about 6 times the rate of fast human speech. In packet radio the actual data rate is a little lower because of the extra flag, address, control and frame checking bits needed to make packet transmissions possible. At the 1200 baud rate, the overhead amounts to about 130 to 150 milliseconds per packet or an effective data transmission rate of over 120 characters per second or about 25 WORDS per second. That's still really moving compared to CW or the human voice.

Almost all of the voice 2 Meter M/S work in the past has been done on Single Sideband. Since stations can't hear each other until a burst is heard and since that burst will probably be very short, tuning in a SSB station to within 100 Hz is not very easy to do. With packet radio, the tones going into its modem have to be within about 100 Hz of the required frequency. Once the frequencies have been set properly at both ends of the path there is another problem to be faced and that is one of doppler shift which occurs on many meteor bursts. By using Audio Frequency Shift Keying (AFSK) of an FM transmitter the problem of the doppler shift is reduced. However the price to be paid by using FM AFSK instead of SSB is that a much greater signal strength is needed at the receiver to produce the desired reliability. 17 to 23 dB of quieting is needed by most of the available Packet Radio modems to get good copy.

Although the 6 Meter band would produce longer bursts and less doppler shift than 2 Meters, most Packet Radio experimentation on VHF is being done on the 145 MHz band. There are also many more FM transceivers on 2 than on 6 Meters so tests were run during the 1984 Perseids meteor shower to prove (or disprove) that FM can be used as a mode for meteor scatter Packet Radio communications over a path of 900 to 1200 miles on the Amateur 2 Meter band.

Packet Radio stations on the east coast of the U.S. attempted to communicate with similarly equipped stations in the mid western United States using the following standards:

- 1) FREQUENCY = = = = 145.050 MHz
- 2) E.R.P. = = = = 1000 Watts erp (minimum)
- 3) Transmission Sequence = Random (beacon mode)
- 4) Transmission Mode = = = FM AFSK
- 5) Suggested Packet mode parameters for TAPRS boards are listed below.

MTO and/or MFROM were set to ALL (This allowed you to see all Packet Radio activity on the channel).

For participating in the transmit phase of the 2 Meter Packet Radio meteor shower test additional setup recommendations were:

Set BTEXT to a brief message with at least your grid locator. See article in Jan 1983 QST page 50 for how to determine your grid locator.

Set UNPROTO to your state abbreviation so even if you go to the CONV mode and only a carriage return is typed, the result will be seen as your callsign plus state. Other TAPR boards would see transmissions of a carriage return sent by this station as K1HTV>MD, because I would have set the TO address field with the UNPROTO command to the abbreviation of my location which is MD.

Set BEACON to BEACON EVERY 1

Set XMITOK to ON (If a TAPR board is set up in this manner, the beacon text will be sent once every 10 seconds.)

If beacon messages are being copied successfully via meteor ionization and one wished to try to make a connect with the station heard it was further suggested that the TAPR board FRAC command be set to 1 (one second). Next, set the RETRY command to 0 (infinite retry) which means that the board will keep trying to connect every FRAC time to the station who's call is in the CONNECT command. It was recommended that if a CONNECT is not made within 10 to 15 minutes, that the stations either revert back to the BEACON mode or move off the 145.050 MHz calling frequency.

Stations that wished to run meteor scatter schedules with other 2 Meter Packet Radio stations were asked to QSY to another frequency AWAY from the proposed M/S Packet CALLING frequency of 145.050 MHz.

If participating stations had the capability of capturing data on disk from their Packet boards it was suggested that they do so at all times while listening on 145.050 MHz, especially during the hours when no one is in the shack.

For those not familiar with the Perseids meteor shower, it peaked this year on August 11th. It generally produces meteors at least 4 days before and after the peak day. During the peak of the shower as many as 60 meteors per hour are not uncommon.

Ralph Wallio, W0RPK, of the Central Iowa Technical Society also performed the same test on the 6-meter band at 50.505 Mhz using the same procedure(s) as described above. He started transmitting at 2045 CDST on August 2, 1984 from Indianola, IA. Over a 9-1/2 hour period, Bob Carpenter, W3OTC, in Rockville, MD, received 75 beacon packets out of approximately 3500 transmitted (roughly 2%). W0RPK was running 265W into a 5-element beam, and W3OTC was receiving with a 6-element yagi and preamp.

Also in Maryland, K1HTV and W3IWI were each sending beacon packets every 10 seconds on
(continued on page 9)

(continued from page 8)
145.05 Mhz FM (using BEACON EVERY 1 on TAPR boards) all through the night of August 3, 1984. At about 07:00 UT, the following came through at W3IWI, showing that they weren't alone:

W0RPK>BEACON:METS CAT IA EN31

Tom Clark saw it come through and began to send connect packets every 2 seconds (using FRACK 2) to Ralph. Later in the morning, the following came thru again:

W0RPK>BEACON:METS CAT IA EN31

K1HTV reports receiving a connect packet from W0RPK and W0RPK received one of W3IWI's connect packets.

The following is a text of transmissions which were part of what is believed to be the first two way Packet Radio meteor scatter contact by Radio Amateurs utilizing the 2 Meter Amateur band. The contact was made by Ralph Wallio, W0RPK in Indianola, Iowa and Rich Zwirko, K1HTV in Glenn Dale, Maryland during the peak of the Perseids meteor shower on August 12, 1984.

The packet transmissions of W0RPK, received by K1HTV were captured and saved on a disk file. Both stations were using TAPR terminal node controllers (TNCs) and operation was in the unconnected mode. Using the TAPR's UNPROTO command, either a call sign or a signal report was put in the TO address field of each packet. With the TNCs in the conversation (CONVERS) mode, a series of carriage returns (using the repeat key) produced a barrage of packets sent at the rate of over five packets per second. Thirty second transmission sequences were used with the westernmost station transmitting the first half of each minute. Both stations used Frequency Modulated AFSK.

(Transmissions began at 03:00 UTC with signals being printed by K1HTV within the first 15 minutes.)

cmd:W0RPK>K1HTV:
W0RPK>K1HTV:
W0RPK>K1HTV:

(In the first 53 minutes of the schedule eight bursts were heard, lasting anywhere from a fraction of a second to about six seconds. None of them produced copiable data. Then at 03:54 UTC an overdense meteor ionization produced a long burst of 23 packets of S6 reports. Signals from W0RPK during this burst were strong enough for packet reception for only four seconds of the 12 second long burst. It looked like this.

cmd:W0RPK>S6:
W0RPK>S6:
W0RPK>S6:
W0RPK>S6:
W0RPK>S6:
etc.

(23 of these packets were received in this one transmission. K1HTV then began transmitting reports of S5RRR to W0RPK. In the next 90 minutes, between 04:00 and 05:30 UTC, eleven bursts were heard but no data was copied. Then at 05:45 UTC a single packet containing the "Rogers" was copied.)

cmd:W0RPK>S1RRR:

And with this transmission the first two way Meteor Scatter Packet Radio contact on the 2 Meter Amateur band was completed.

During the 2 hour and 45 minute period of time that it took to make the 2 way packet QSO, activity was monitored on 3818 KHz, the primary frequency used to arrange meteor scatter

schedules. Numerous 2 Meter M/S QSOs were reported being made on SSB in the range of 800 to 1200 miles. The majority of these were completed in less than a half hour. It is not surprising that it took so much longer to complete the packet QSO. Although the data transmission rate of the packet radio transmissions was about 8 times as fast as the SSB rate, the signal to noise ratio needed for FM AFSK wasn't often realized on the meteor bursts encountered. The duration of meteor bursts vary as the reciprocal of the square of the frequency ($T=1/F^2$), and the received signal strength of meteor bursts vary as the reciprocal of the cube of the frequency ($S=1/F^3$). It is very apparent that the 50 MHz or 29 MHz amateur bands would be a much better choice for any future Amateur Radio packet meteor scatter system. There are a number of other modulation schemes which could be used to improve signal reception.

This whole exercise of attempting to make the first meteor scatter packet radio QSO was done, as has been done many times in our hobby, to prove that it COULD be done. Now let us get on with the experimentation on improving the WAY that it is done, with better hardware and software.

The following is a circuit that shows the CONNECT status of your TNC on remote LEDs. The parts needed are a 74145, two TRI-COLORED LEDs, four 330 ohm resistors, (kit only, 25 pin female plug). Optional: red LED & resistor for FRMR condition, piezo electric beeper, switch, 1.8K resistor, and PNP switching transistor for alert circuit. The following shows where to connect wires between the parallel port on the kit or the 6520 on the beta board (or kit), to the 74145.

74145 pin	Kit port pin	6520 pin	function
16	23	24	+5 volts
8	25	1	ground
15	15	2	PA0 to A input
14	2	3	PA1 to B input
13	16	4	PA2 to C input
12	25	1	D input to ground

On the 74145, pull up pins 2, 3, 5, & 6 to +5 volts thru the 330 ohm resistors, then connect the two LEDs as follows:

LED1 flat to pin 3, other to pin 2,
LED2 flat to pin 6, other to pin 5.

If you want a CONNECT alert circuit (pager), connect the base of a PNP switching transistor to pin 6 of the 74145 thru a 1.8K resistor. The emitter thru a switch to +5 volts and the collector to the sonalert or a simular beeper, grounding the other side of the beeper.

How it works: The 74145 is an open collector BCD to 1 of 10 decoder. The TNC provides a BCD encoded output from the parallel port that after decoding by the 74145 provides the following states:

Pin 2 active low = DISCONNECTED
Pin 3 active low = CONNECT attempt in progress
Pin 4 active low = FRMR condition
Pin 5 active low = DISCONNECT in progress
Pin 6 active low = CONNECTED

LED1 is red on DISCONNECTED, green on CONN in progress. LED2 is green on CONNECTED, red on DISC in progress.

Comments or queries can be made to: Phil Allbright, KD0EB, 3852 Neosho Ave. St. Louis, MO, 63116 (an S.A.S.E. would be appreciated).

23CM Bandplanning In C.A.

by Harold Price, NK6K

Southern California has one of nation's largest densities of 144, 220, and 440 MHz transmitters. The southern California metropolitan area of 200 miles north-south by 50 miles east-west contains 10 million people. There are more than 50 mountain peaks in use by amateurs, ranging from a few hundred to 10,000 feet above sea level. There are hundreds of 144 and 220 machines and more than 300 440 MHz devices on various peaks. Some of these are "closed" machines which are not listed in the various repeater directories. There are five crossband ATV repeaters, with inputs on 70cm and outputs on 23cm. There are long waiting lists for coordination on all bands. "This band closed, please move up" signs are posted.

Into this fray comes a new mode, digital communications. The 23cm band (1240 - 1300 MHz) is the lowest band with room for wideband data (1.5 Mb, 3 MHz) in our area. On August 25, 1984, a meeting sponsored by the local frequency coordinating group (SCRRBA) was held to discuss the 23cm band. An ad hoc committee of NK6K, WA6JPR, WB6YMH, and WB6HHV attended the meeting to present the digital mode's point of view. The following paper was prepared for distribution at that meeting. A band plan was agreed on and will be in place in southern California for the next three year, at which time another band planning meeting will be held.

High Speed Digital Communications in the Amateur Radio Service With Special Attention to Activity in Southern California On the Occasion of the 23cm Band Planning meeting August 25, 1984 or "Who are these guys, anyway?"

Summary

Digital Communications in the Amateur Radio Service, of which "Packet Radio" is the current popular incarnation, has just entered a period of explosive growth. In the past year, packet radio has grown from a small number of isolated experimenters to a well coordinated group of 1700 active users nationwide. The growth rate is increasing as more amateurs are exposed to the digital mode. As has been the case in the past for other modes of communication, the Southern California area is in the forefront of continued experimentation and innovation in amateur digital communications.

Digital mode Spectrum needs on the 23cm Band

Medium bandwidth: These channels will be used for heavy local activity. Bandwidths will be in the 100 kHz range. The LA to SD corridor already is sufficiently crowded to warrant this type of service. Equipment requiring this bandwidth is being designed in several areas of the country.

High bandwidth: Used for major trunking between high density areas. The SF <-> LA <-> SD network will certainly support at least one such path with in 5 years. A 1.5 MHz digital channel has been tested in the Bay area. Bandwidths nearing 1 MHz have been used experimentally in LA. A duplex pair using several point to point digital relays is a likely eventual goal.

We see a need for a full duplex 6 MHz channel pair. This will consist of several channels of varying width as technology and load conditions dictate. This will allow room for "production" networks, links, and gateways, as well as room for experimentation and future expansion.

Since the exact data rates and bandwidths to be used have not yet been standardized, it would be disadvantageous to attempt to set aside digital "channels" at this time. Instead, a block of spectrum should be set aside for "digital communications", with exact bandwidths and spacings within the block to be left to the regional digital coordinating group. Frequency is just a small part of the total coordination problem for digital channels, with signaling rates, protocols, data modulation, network addressing, and other parameters all playing a part in adjacent channel and shared channel assignments. An initial unchanneled approach will lead to more effective use of the frequency blocks set aside for digital use.

Background

Prior to 1980, digital transmissions on the amateur radio bands were primarily limited to "RTTY", or more correctly, Baudot transmissions. Growth in this mode has remained steady through the years, with a recent spurt caused by the ubiquitous microcomputer. Because Baudot transmissions are limited by convention, equipment, and the FCC to low signaling rates, the bandwidth requirements are proportionally low, fitting nicely into even the DC bands.

After 1980, when the FCC permitted the ASCII computer code on the amateur bands, the fuse was lit. A digital boom was soon to follow. The reasons were simple. First, most computers speak ASCII as a native tongue. ASCII allows 128 different characters, Baudot less than 60. ASCII could be sent much faster, by law 16 times faster on 144 MHz, and 256 times as fast above 420 MHz.

At these speeds, and with the greater level of flexibility offered by a larger character set, something called "overhead" became more palatable. Overhead, extra characters sent in addition to the actual conversation or message, allows several things to occur. First, it provides for "correctness". Information corrupted by static, multipathing, fades, interference, or acts of God could be detected and either corrected or simply retransmitted. Second, it provided the capability of networking, or automatic message routing.

To enable networking, the information being sent is broken down into small parts. Each part has some overhead added, the call sign of the station sending the message, the call sign of the station receiving the message, and a list of stations which will repeat the message, passing it through the network.

Finally, breaking the message into small parts allows near simultaneous sharing of a single frequency by several stations, each carrying on conversations with different stations in different parts of the network. Each individual station would see no interference, as if he and the party he was speaking with were the only users.

This can be likened to an inter-state network of linked voice remote bases/repeaters. Twenty or more users would be carrying on conversations traversing the entire length of the network, accessing the network through different or the same mountains, with the network automatically switching links on and off; sentence by sentence, correctly routing each word to the correct party. Each user thinks he has sole use of the net, and each voice is as clear as if it were coming off a compact-disk digital audio player.

(continued on page 14)

The above scenario compares to SSB on 20 meters in the same manner as current amateur digital techniques compares to traditional RTTY.

Packet Radio, a form of digital communications, came to Southern California in 1982. It was experimental, based on work done in San Francisco and earlier work in Vancouver, Canada. By the end of 1982, there were six active users of packet radio in Southern California, four in LA and two in San Diego. In 1983, Packet Radio took a quantum leap. From a nationwide base of less than 100 active users, packet jumped to 300 users, 30 in Southern California. By August of 1984, packet had grown to 100 users here, and 1700 in the US and Canada, with small but growing enclaves in 14 other countries. Each of these users has compatible digital communications equipment, enabling data exchange between incompatible computers. More than 85% of these hams built their own packet radio "controller", either from their own design or from a bare PC board and a large kit of parts. Preassembled "Plug the AC cord in the wall" equipment has only just arrived on the scene.

Packet growth shows no signs of slowing down and is continuing to grow at an increasing rate. What does this mean in terms of spectrum utilization by the digital mode in the near future? In 1982, the FCC again raised the digital speed limit. Bandwidths are given now instead of just signaling rates. The bandwidth on 70cm is 100 kHz, above 1215 MHz bandwidth is unlimited.

Currently, packet radio is centered on a pair of frequencies on the two meter band. Coordinated as a digital communications pair by TASMA in the late 1970s, 145.36/144.76 currently supports the bulk of packet activity. Arranged as two parallel paths for experimentation and load sharing, the pair supports seven digital repeaters, a mailbox system and two CP/M computer systems. Usage statistics kept by the computers show more than 40 users active on a weekly basis in the LA and SD areas. Other groups in Santa Barbara and Twenty-nine Palms will soon be linked into the network.

In a continuing experiment, a full duplex RF repeater is in use on 146.745/146.145. This pair supports a mailbox facility and an additional set of users.

The initial experiments on two meters has shown us that although theoretically possible, 100 users can not effectively share a 15 kHz channel. Studies have shown that the maximum data throughput of a shared channel is 18% of an unshared channel. We have also seen peak demands on our prototype network of four concurrent users running at 120 characters/sec. Using the figures of 480 characters/second divided by 18%, the LA to SD path requires a data rate of 26kB. Thus, we could fill a 50 KHz channel with data, not counting guard space on either side, tomorrow.

In the near future, these narrow bandwidth channels will serve as feeders, moving data from sparsely populated areas to high density gateway areas. An additional channel on 441.5 MHz has been coordinated for this purpose as well.

We are solving the congestion problem now by operating less, not something a ham picks as first choice. Activity will continue to grow. As more high speed linking occurs in our area and between our area and others, multiple channels will be required. Another expanding force on bandwidth will be new technologies. Just as the current activity could be envisioned but not implemented using RTTY, new digital applications are almost attainable but out of reach with current data rates. Multiple concurrent digital voice and data streams require wider bandwidth. Wideband experiments are already being performed in various areas of the world, 9600 baud in

Ottawa and St. Louis, 56 kb in Florida, 100 kb in Sweden and soon in New England, 1 Mb in LA, 1.5 Mb in the Bay area.

Room to experiment and room to grow are required to help expand the newest amateur radio mode. A nationwide voice network of the type used in the example above, implemented on a digital network, might not be that far off. Who would have believed, 20 years ago, what hams are doing now? Hand-held color TV linked thru a repeater, data at 120 characters a second from LA to New Zealand thru an amateur satellite 22,000 miles high, hand held 70cm chats between LA and Texas.

"Ok Fred, the mouse beamed over in one piece but he's not breathing, crank up the power and try your mother-in-law".

★★★★★

Gary Kaatz, W9TD looked over Lyle's article on link rate capabilities and reported link operation at 9600 baud with his Beta TNC.

The Beta TNC does not have a high speed clock option and is limited to 4800 baud. In order to get the x32 clock for the WD1933, I divided the 6551 baud rate clock of 1.8432 MHz by six in a 74LS92 to provide 307.2 KHz to the WD1933 (32*9600). I tested using 9600 baud for the terminal rate and used a digital loopback, to allow connecting and digipeating through myself.

There was no problem in sending short packets with up to eight digipeaters as long as I waited for the packet to be ACKed. This was not the case when the link was overloaded. If I used only three digipeaters and sent a long packet (240 characters), the TNC sent it once then stopped. Sometimes after things appeared to have stopped, hitting another carriage return would induce the previous packet to continue. Other times the TNC would just not ever transmit again, requiring a software reset to recover (RESET command). With seven digipeaters, I could even cause the TNC to "go off into the woods" by rapidly sending several one character packets before the first was ACKed. Once, the TNC erased the NOVRAM during this test. Even at a link rate of 1200 baud, I observed the tendency to stop transmitting.

I then borrowed a kit TNC in order to monitor the activity using TRACE (I used the high speed clock option and found that it worked just as Lyle reported). There were a lot of extraneous packets flying around, no wonder the TNC became overloaded. Even after a packet was received, but before the ACK filtered back, it might be sent several more times so the receiver was sending back many REJ ACKs. Even with a noiseless digital channel (a wire) sometimes the packet was not received correctly and had to retry.

I then connected the two TNCs so that they could communicate with each other by connecting the TXD of one WD1933 to the RXD of the other. With no digipeaters I could even send a long file, loading it into the kit TNC at a rate of 9600 baud and watching it at a rate of 300 baud on the Beta TNC. Using two digipeaters, the Beta TNC would eventually crash. The other way around (including the terminal rates), even with no digipeaters, the Beta TNC would lock up and would not transmit as reported above. Even though it would not transmit, it would still receive, but not ACK.

I then operated the kit TNC at the normal clock rate and generated the x32 clock for the WD1933 the same way I did for the Beta TNC. Now, when sending a file, more often than not one or the other TNC would either stop transmitting or "go off into the woods" even with no digipeaters. I can therefore only conclude that the standard TNC will not support 9600 baud links except by waiting for each packet to clear the link.

TAPR's Future

by Harold Price, NK6K

The following was placed on CompuServe in reply to the questions "What is TAPR doing about level three?" and "How far in the future do you see TAPR selling TNC kits now that there is a commercial interest in the game?"

The following views are mine alone, and do not necessarily reflect those of TAPR, AMSAT, VITA, LAPG the staff management or janitorial depts.

The TAPR folks are indeed up to something. We now have the TAPR Pascal code running happily under a simulated environment again. When I left my previous employ to work on PACSAT I lost access to the development environment we had used to get the TNC code written. The software, with only one change (a shift(var,4) changed to var shl 4) runs under TURBO Pascal on the Pronto-16 I spoke of earlier. This will vastly speed up development, which has slowed down as of late. Margaret, KV7D is expecting a little packet of joy in July, so she will be home bound during July and August. Look for great things before September.

The plan is to come up with version 4.0 of the TAPR TNC software which will allow testing of both datagram and virtual connection protocols. As I said in a message to Norm, I think the level two wars are over. With 1300 TNCs in the field from 6 "manufacturers" all running the same level two, anyone proposing a switch now is just rocking the boat. The few proposals I've seen for different level twos offer no concrete advantages over what we've got now anyway. Besides, level two is boring (now that we have one that works), the real fun is level three.

There is currently a necessary kludge in AX.25 called digipeating which is a very demented level three feature. Digipeating allows two TNCs to be connected using a third as a relay. Without this simple addition to AX.25, packet may not have taken off as it did, since digipeating allows many more users to reach each other.

TAPR took this benign dementia a step further by allowing multi-hop digipeating, ie. the two end points were connected by an ordered list of digipeaters. We picked an infinite number (8) as the total number of hops. My feeling is that the chances of a packet making 8 hops without getting trashed and then the ACK coming back thru 8 hops without getting trashed is close to zero.

After much kicking and screaming on the part of some vendors, everyone has pretty much followed suit since there are areas of the country where the packeteers are not lucky enuff to include in their number someone with his own repeater channel and a set of users who are willing to cease voice operation. If you haven't got a wide coverage duplex repeater (or even if you have), digipeating is our best bet for now.

Anyway, level two is point to point, with level two+ in current style, multihop dumb repeating. The + in level two will die a happy death when we get level three up and running. Level three links two end points thru multiple intermediate TNCs. The linking is done in an intelligent manner. ACKING is node to node rather than end to end. In level two digipeating, each intermediate point simply regenerates the packet. It does not ACK it. The final end point ACKs it, and the ACK is blindly repeated back to the starting point. If any repeat of the packet, or the ACK, is stepped on or dropped, the packet must start over from the beginning.

In level three, an ACK can occur at each step of the way. Thus, a packet may only have to be re-sent between relay points five and six, rather than starting again at point one. So why don't we get on with it, you might ask?

There are many problems involved. Flow control, network blocking, routing, on and on. To get back to the question, what is TAPR doing?

A node in a level three network will want to be connected to more than one other node. I think this is the case for most of the connection oriented protocol options. We will allow the TAPR TNC to maintain multiple level two connects. This has several implications. First, you can carry on two or more concurrent conversations. Not so good for rag chewing maybe, but great for emergency communications. Imagine a TNC in the local disaster center. Currently you can carry on a conversation with only one other TNC, with limited possibility of a priority break-in from another TNC. With all outlying TNCs connected to the central node at the same time you get closer to what you want, high reliability connections with each of the field guys at the same time.

Next, and even better, you can automatically route one connection stream to another. Here's an example. The following syntax is probably not what we'll end up with, but the idea is:

```
MYCALL NK6K
[1] CONNECT WB6YMH
    [1] CONNECTED TO WB6YMH
[2] CONNECT WA6JPR
    [2] CONNECT TO WA6JPR
ROUTE [1] TO [2]
```

At this point, your TNC is now a network node. Anything that comes in from stream [1] gets acked at level two. The data from the packet gets routed to stream [2] where it gets sent out and saved until an ACK comes in on stream [2]. The versa is also true, incoming from [2] goes to [1].

Now, wouldn't it be great if you could cause the other guys board to make a connection? If I could tell WA6JPR to make a level two connection to WB5EKU? And what we have is the level three function, endpoints linked thru multiple intermediate points. A lot of things are missing, but this simple mechanism allows testing of level three concepts without a lot of hassle on the users part. We will also design an interface (based on asynchronous LABP) between the TNC and its attached computer to allow the computer full control over the link process. This permits the use of the TAPR TNC as a level two black box, with level three functions done in your host.

Do I expect everyone to run version 4? Well, why not? The design goals of the TAPR TNC were to design in one box everything needed to experiment with the uses of packet radio. To get past the issue of level two, and on to applications of packet, and higher level protocols. I think that we have met this goal. The TAPR TNC is now in use in many counties, ZS, ZL, VK, JA, PY, PA, ON, DL. It is in use on many modes, HF SSB at 300 baud, Oscar 10 SSB at 1200 baud, OSCAR 10 PSK at 400 baud, VHF FM PSK at 4800 baud (bell 208 modems), as well as standard VHF FM 1200 baud FSK. On the other hand, version 3.1 can still be used point to point, and thru 4.0 gateways get full access to network. But just as everyone having the capability of being a digipeater added to the
(continued on page 13)

(continued from page 12)
swift growth of packet in spread out or low density areas, so will the ability for anyone to be a level three node speed growth in that area.

But I ramble. The other attribute of a network node is the ability to connect to more than one RF path at the same time. Lets assume a 1200 baud link on 2 meters and a 2400 baud link on 220, feeding a 9600 baud link on 440. Basically, the hardware arm of TAPR is designing a fancy multi-port hardware controller. Several designs have been proposed, one is motherboard with slots for plugging in a number of channel controller cards. Each channel control card is a mini TNC, handling all channel access and level two functions. The mother board passes data between channels as well as handling level three and higher functions.

We don't expect everyone to have one of these, which are called TNC-LINKs, by the way (pronounced tink link). But they will make great mountain top controllers, especially when used with the PACSAT 9600 whiz bang modem.

To answer your final question, how long do I see TAPR building kits. There are two answers, "As long as there is a demand" or "Until we can't stand the sight of them anymore". Since I'm not located in the teaming hub of Tucson, but am instead located in the outlying area called LA, I haven't been pressed into the chain gang of kit packaging, but isn't much fun. Especially when serial number 1000 has long since gone out the door. The kits are TAPR's only source of income. And when we say we are selling them at cost, we aren't kidding. An extremely small amount of each \$240.00 goes into our fund for future development, I've forgotten exactly how much. Remember, no one is on a salary at TAPR. A number that does come to mind is the cost of the cabinet kit. Your cost, \$69.00, our cost, \$67.00. Our original goal was to make packet available to a large number of people at reasonable cost, delivering as full a function device as we could. It is possible to deliver less function for less cost. It is possible to deliver the same function assembled, tested, and warranted, for a larger cost. There are several market niches out there, and we will continue to ship as long as 1) there is a niche for us and 2) we're having a good time.

The Tucson folks tell me that they have gotten some phone calls in the last few days saying they saw a message on HAMNET that TAPR wouldn't be making kits anymore now that AEA was making the PKT-1. I don't remember seeing that, but here is a message saying it ain't so. We'll keep cranking them out, with the above mentioned caveats. Is the PKT-1 worth the additional cost?

It depends on how you value your time. Take the kit, \$240, and the cabinet, \$70.00. Total cost \$310.00. You're looking at about 11 hours construction time. If you consult for as little as \$17.00/hr, in those 11 hours you've made up the difference. Like to buy the component and get on with higher function experimentation? Want the security offered by a reputable commercial dealer? Spend the money. Like to build? Buy the kit.

Only got \$150.00 but want to get on packet? Interested in local two meter FM work, or want to run a low cost remote digipeater? Buy the GLB. Got only \$150.00 but want to run 300 baud HF, oscar 10 with on board filtering, or experiment with 4800 baud? Want a 240 page manual/tutorial on packet radio? Save up some more money.

Want to do all of the above and like to roll your own? Did you get in on the \$50.00 Xerox 820 board blow out? Keep your eyes down south, a group in Florida is brewing a board that plugs into the PIO chip socket that adds dual channel HDLC hardware. Expect to see the TAPR code ported to that hardware configuration soon as well.

These quickey comparisons are vastly simplified, of course. Each of the TNCs has its own niche. As always, think about what your needs are, then spend as little as you can to get it.

Are we having fun yet? You bet!

A for-profit company would be crazy to discuss future products like this before the product is ready to ship. But we're a non-profit R&D company, trying to make packet the mode of the future. Just remember, you saw it here first.

★★★★★★

Tucson Amateur Packet Radio (TAPR), an international Amateur packet radio research and development group based in Tucson, Arizona, is proud to announce the opening of its office, effective Monday, August 20, 1984!

The office address is:

Tucson Amateur Packet Radio
1016 East Pennsylvania Avenue
Suite 302
Tucson, AZ 85714

The mailing address remains:

Tucson Amateur Packet Radio
P.O. Box 22888
Tucson AZ 85734-2888

The telephone number is: (602)-746-1166

The office hours are: 9:00 AM - 5:30 PM
(Mountain Standard Time) Monday through Friday.

The gentle voice at the TAPR end of the line belongs to Karen Makus. Karen is a non-technical person, so please don't ask her how to write a terminal program for your packet station! However, in her role as Office Manager, she will do everything she can to expedite servicing your information requests, providing spare parts support for your TAPR TNC, filling orders, etc.

Technical questions will be routed to volunteer staff for answering, so please mail such questions to the TAPR P. O. Box.

It is our goal to provide 48 hour (or faster) turnaround on all standard transactions (memberships, renewals, TNC and parts requests, general information needs, etc.) and faster service on non-standard ones. We at TAPR wish to thank you for your continued support, and look forward to being of greater service to you.

On October 7, 1984, a group of Nebraska amateurs formed the Cornhusker Amateur Packet Radio Association (CAPRA). The next meeting will be at 1300 CST on January 6, 1985 at the home of Lyman Nelson, WB0IEN, in Hooper, NE.

Hank Magnuski, KA6M, has had his new 9600 BPS switched network analogue MODEM product reviewed in the July issue of Byte magazine, Page 354. Hank is the proprietor of Gamma Technology in Palo Alto, CA when he isn't working on packet.

The new product is an intelligent MODEM built on an IBM PC card that hustles along at 9600 BPS. This is no mean trick over the telephone network and is a significant breakthrough in telecommunications capability for the PC. If you're moving much data around the country on the switched network, especially in the middle of the night, this product should prove in on a very short pay back period and find a large and growing market.

PACtivities

On 8/1/84, the Board of Directors of TSARC, the Tri-State Amateur Repeater Council, meeting in Executive session, took the unprecedented step of reversing its original position on the coordination of non-traditional modes such as packet radio, RBBS and MSO systems and simplex autopatches. TSARC had originally decided that such operations, because of their simplex, single-emitter concepts, did not really relate to the coordination philosophy already in place for repeaters using the classic two-channel input/output frequency structures and principles, and that consideration of requests for coordination would have been inappropriate.

After much discussion and deliberation, the Board voted to give full consideration to the coordination of such simplex operations as packet radio, radio bulletin board systems (RBBS), message storage operations (MSOs), mailbox systems, and legitimate simplex autopatches, and resolved to:

(1) Establish the concept of the coordination of certain specific VHF and UHF channels based on the mode of operation, as well as geographical area and physical separation considerations;

(2) Recognize, acknowledge and support the use of the frequency 145.010 as a de facto East Coast standard, and to formally recommend that 145.010 be reserved for exclusive use by stations operating packet radio systems;

(3) Recognize the requirements for a special wide-band channel coordination and allocation in the 220 MHz band, and establish and coordinate a single 100-KHz wide channel from 220.500 to 220.600 MHz for exclusive use by packet radio systems, possibly for 56 kbit/s packet radio trunk and backbone services.

This last item was given exceptional urgent emphasis and attention in view of the recent public statements by Robert Foosaner, Chief of the FCC's Private Radio Branch. In his speech at the FCC Forum at the recent ARRL National Convention in New York City, Mr. Foosaner clearly outlined the need for allocations of additional new channels in the Land Mobile Service, and that the Commission would be looking at all parts of the spectrum for suitable frequencies, including the possible re-assignment of some portions of the amateur radio band at 220 MHz. The Board noted that certain commercial interests had already filed formal petitions asking specifically that the Commission re-assign the frequencies 216 to 222 MHz to the Land Mobile Service.

It was the Board's very strong feeling that the coordination of the 100-KHz channel 220.500 to 220.600 MHz would conform to the requests and needs of amateur operators working in the most sophisticated technologies, and clearly demonstrate to the Commission that the Amateur Service's most advanced technologies were finding a home in the lower portion of the 220 MHz band, establishing maximum visibility and credibility, something that has not been noteworthy on 220.

The Board also established a requirement for the re-evaluation, and revision of existing TSARC recommended technical operating standards, including immediate efforts to study and incorporate new technical operating information appropriate to the packet radio, RBBS/MSO and other non-voice operating modes. TSARC welcomes and encourages input, comment and suggestions from other coordinating councils in these matters. Comments of a technical nature can be mailed to:

Norman Sternberg, W2JUP Vice-Director (516),
TSARC Box 125, Farmingville, NY 11738

The AMSAT/APL packet repeater in Maryland is now signing the call W3VD-5 on 145.01 running 25 watts. Reports from MD/DC users indicate very good coverage over a 30-50 mile radius.

.....
The second informal meeting of OPEC (Oahu Packet Radio Enthusiasts Club) met the first week of July. Of the known 12 Packet Stations in Hawaii, seven were in attendance. Eleven of the stations are using TAPR TNC boards. (There is one GLB out there!) There are at least two Packet Stations on the neighbor Islands.

Several months ago the video tape of Pete Eaton's talk in Iowa was obtained by KH6FIC and has been shown to the Honolulu Amateur Radio Club and other groups. This has been a stimulation for many to 'get-into' Packet Radio! How Pete managed to pack so much information in a one hour tape is amazing in itself. But then, Pete is a pretty amazing guy!

The initial OPEC group is: AH6AC Dale, KH6DD Pat, KH6FIC Jim, KH6FMT John (on Kauai), KH6GMP Gary, KH6GPI Hal, KH6JEO Tony, KH6NP Bob, KH6PS John, WB7SZC Jay, KH6WY Jack, and WH6AMX Rick. Rick is the AMSAT Coordinator for the Pacific and is among three others who have had Packet QSOs via OSCAR-10! (Blame Gary for the club name!)

The big event at this meeting was the decision to install a dedicated DIGIPEATER (hopefully on one of the Mt. Peaks in an attempt to cover the entire State). Enough money was tossed into the Calabash Bowl that a TNC has since been ordered by Dale, AH6AC, who will assemble and test it. A 2-meter rig was offered for DIGIPEATER use and I am sure an antenna will make an appearance. In any event a good LAN should be up and running soon!

Most, if not all of us, use personal computers as terminals; and most use additional software rather than straight 'dumb-terminal' configuration. There are at least four of us who use 4800 baud terminal interfaces and that makes it all the more interesting! Several are using Ascii Express "Professional" and that goes quite nicely with the TNC. In fact, Dale, AH6AC, is leaving his Apple on all day as a BBS which permits the rest of us to upload and download files as well as use it as a Packet Mail-Box. Following the advice of Lyle Johnson and Harold Price in the last PSR concerning the setting of AWLengh to 8 and PARity to 4, we can now exchange binary as well as text files. We expect to get a bit fancier BBS by the time the digipeater is up and running! In the meantime Dale's BBS layout serves us quite well.

Only one had any admitted difficulty in getting his board up and running. That one was John, KH6FMT! He couldn't get his PTT LED to turn off. It was really giving him fits until he finally found that the DIP socket for the HEX Inverter (U21) had an internal short which of course was corrected by replacing the socket. (John will tell you that his faith in OHM's law is now reaffirmed. But for a while he was doubtful about continuity checking!)

Without exception all of us have been greatly impressed by the professional board layout, the outstanding firmware, and the great documentation provided. How it all got done without a lot of hired help and how self imposed deadlines were met is a tribute to a lot of very dedicated people.

The address for OPEC is P.O. Box 1355, Pearl City, Hawaii 96782. ALOHA NUI LOA from here.

(continued on page 15)

(continued from page 14)

The Rocky Mountain Packet Radio Association (RMPRA) was organized earlier this summer. The membership is now 40, and with annual dues of \$20 the treasury is building nicely. When we look to the expense of linking hardware and related costs, however, we need more money. One approach we are using may be of interest to other packet groups.

The largest amateur supply dealer in the region has agreed to put an assembled kit in operation at his store for demo purposes. At this time he does not stock any of the commercial packet gear. The RMPRA is supplying the TAPR TNC kit board for the demo.

We expect to boost packet activity in the area, get good exposure for the TAPR TNC, and expand our membership. We will at the same time advertise that the kit can be had in assembled form for an additional \$75. RMPRA members will do the assembly while the RMPRA treasury benefits.

The Rocky Mountain Packet Radio Association (RMPRA) is now operating, what we believe to be, the most sophisticated bulletin board around.

The system used is a packet modified version of The Bread Board System (TBBS) by Phil Becker, W80EIV. The system was donated and modified by Phil, and his distributor Dave Ebert, W7RH (Ebert Personal Computers, Aurora, CO).

Don Brown, N0BRZ, is the SYSOP. He has supplied a TAPR TNC kit, TRS-80 Model III, radio, and related equipment. It operates 24 hours per day and is capable of monitoring several frequencies as well as standard telephone BBS operation. Our Pikes Peak geostationary digipeater at 14,110 feet provides wide area access to the BBS.

Anyone interested in sampling the system we are using can call the TBBS Headquarters Board at (303) 690-4566. Don's number for the RMPRA board is (303) 452-4735 (word=8, parity=none, stop=1, terminal echo=on or half duplex, 300 baud for the time being).

Call signs and names of packeteers in the D.C. area (T = TAPR TNC, V = VADCG TNC):

K1HTV (T)	Rich	KA1GD (T)	Andy
KA1TB (V)	John	WB2KDR (?)	Jerry
K3HOI (V)	John	KE3Z (T)	John
W3AUN (T)	Bill	W3IWI (VT)	Tom
W3OTC (T)	Bob	W3TMZ (T)	Jack
K3TCT (T)	Bob	N3DCI (V)	Bill
WA3MEZ (V)	Rod	WA3WQZ (V)	Chuck
W4CQI (T)	Cliff	W4PUJ (T)	Dick
W4MIB (V)	Bill	WB4NFB (V)	Bill
WB4APR (V)	Bob	WB4JFI (V)	Terry
WB5MMB (V)	Sandy	WD5DBC (V)	Howard
K8MMO (V)	Dave	KA9NWB (T)	George
AJ9X (V)	Mike		

At the last meeting of the Minnesota Repeater Council (MRC), Rick Whiting, W0TN, agreed to conduct a study of, and prepare a recommendation for, the provision of frequencies for digital communications service in the frequency coordination policies and procedures. As a result of his study he plans to propose at the next MRC meeting that five 20 kHz channels beginning at 145.01 Mhz and ending at 145.09 Mhz be set aside for digital communications including digital repeaters (frequencies are channel centers). Coordination of specific stations on these channels is not being proposed. Assignment and use of said channels for digital services (meaning packet radio at this state of the art) will preclude their use by non-digital stations.

At approximately 0700 UTC on June 7th, 1984 a new packet station in Munich, DL3MAO, "Bernie" reported copying packets from Wes, K7PYK, in Arizona on the Oscar 10 digital channel.

Bernie reports that there are four TAPR boards on the air in the Munich area, and another four in the Hannover area. He also has learned that there is now an active group in Switzerland, near Zurich.

Junior, PY2BJO, of Sao Paulo, is interested in running a test of HF packet communication using the phenomenon of TE (Trans-Equatorial) propagation, since he has observed strong signals from the US between 2100 and 2200 UTC. He suggests the use of 28.7 Mhz with F1 1200 baud 1000 Hz shift or 29.5 Mhz with F3 Bell 202 AFSK. Junior can be contacted via his call book address or on the OSCAR 10 packet frequency of 145.832 Mhz on the downlink for setting a schedule.

Following is JA1SYK's report on Packet meetings held in JA3. He was in that area on business and attended.

On the evening of June 15th I attended a Packet meeting at the shack of JH3BJN. I arrived at his house before nine. I could meet a lot of stations who are interested in Packet Radio communications. Those present at that meeting included:

JA3RCT	Hisamathu-san	JARL Kyoto shibu-cho
JA3IAF	Ozaki-san	versed in P. computer
JR3NWZ	Nakamura-san	same as above
JF3GFH	Mashiba-san	St. of Kyoto Uv.
JG3NTF	Inoue-san	study abroad in USA
JH3UBF	Minami-san	came from Shiga Prh.

We were successful in exchange of packets from his PC-8801 MK2 to his PC-8001+PC-8012 using my Z-8530 boards. I told them everything I have known from my experiment of Z-SCC and patched 1/tipm. We discussed Modem, TNC, HLDC, Gateway, Digipeater, Mail-box and much more.

Hisamathu-san who is JARL kyoto-shibu-cho said let's do the Packet Radio in Kyoto. Nakane-san will connect his GLB-TNC and his Z-8530 board through the modem. He copied the patched 1/tipm on C-DOS and P-DOS for his PC-8801 MK2.

They returned to their home at about 3:00 AM. I expect that they will succeed with the Packet radio experiment in Kyoto area.

Re. PCBs of AFDEM-JA, Nakane-san told me that he ordered 20 PCBs from his friend for alfa-test.

KD7UW reports that packet radio is alive and well in Seattle, WA on the following frequencies:

147.600 simplex ---- main digipeater and mailbox.
145.010 simplex ---- planned for regional linking.
224.650 simplex/duplex ---- planned for linking.

We are proud to announce the arrival of two prospective packeteers into the ranks of TAPR. In July, Dan (KV7B) and Margaret (KV7D) Morrison brought home a baby girl who they named Ruth Ellen, and was followed in August by another girl, Janna Marie, born to Pat Snyder, WA0TTW, and his wife Julia.

A Fuel For Thought

by Jan King, W3GEY

The Space Shuttle has modified the method by which space-bound payloads enter orbit for the foreseeable future. The STS offers the promise of lower payload cost and the ability to carry large payloads into orbit to mention but a few of its primary objectives. For very low cost payloads such as those pioneered by the radio amateur community (the OSCAR series), the Space Shuttle poses, however, a number of severe engineering obstacles which have become major stumbling blocks to the exploitation of this valuable resource. Not unlike most free flying satellites, the communications satellites launched by radio amateurs and used in the Amateur Satellite Service are intended to meet long life objectives. In addition, to meet mission objectives for the communications service to be provided either a geostationary transfer orbit or a sun synchronous polar orbit must be attained by the spacecraft. Unfortunately, neither of these objectives can be met by the standard provisions of a Space Shuttle mission.

STS orbits, typically 296 km in altitude and inclined from 25 to 57 degrees are unstable. A small spacecraft, with a low surface area to mass ratio, will decay from such an orbit in a matter of months. This class of orbits, with a few exceptions, is also unsuitable for communications experiments of interest to the Amateur Satellite Service. It is therefore a necessary requirement for Amateur Satellites and other free flying spacecraft seeking stable orbits to carry a propulsive capability if launched by the Space Shuttle.

Having accepted the burden of a propulsive system as an added spacecraft complexity, yet another problem becomes apparent. Classical propulsion systems employed by satellites are characterized as hazardous devices. Due to the manned presence on board Shuttle safety considerations are necessarily more stringent when using this method of launching a spacecraft. The added complexities and paperwork resulting from the inclusion of hazardous devices on board Shuttle launched satellites conflicts with the low cost nature of these programs and may make such payloads totally impractical or viable only if launched by alternative methods. This problem is exacerbated by the fact that most orbit alternatives can be reached from Shuttle orbits only by multiple delta-V maneuvers. This requires multiple solid rocket engines or a restartable engine on board the satellite, further multiplying the safety hazard problem.

A solution is sought to the "Shuttle Dilemma." The Shuttle Dilemma may be defined as follows:

(1) A Shuttle payload is always two burns away from the desired orbital elements when separated from the cargo bay.

(2) The cost of NASA safety approval for a propulsive device used aboard Shuttle by a low cost user is approximately a factor of three higher than the entire cost of the payload itself.

(3) As a rule of thumb, the mass of the paperwork necessary for NASA approval of a hazardous device for a Shuttle flight is greater than or equal to the mass of the payload.

While the above may seem humorous, these statements are all too true and must be dealt with squarely by would-be Shuttle low cost payload designers.

A propulsion system that would solve the Shuttle Dilemma could be expected to have the following characteristics:

(1) The propellant used should not be a chemical, pressure or explosive hazard as defined by NASA or the USAF (ref. AFETRM-127-1).

(2) The loading of propellant into the spacecraft should not constitute a hazardous activity. No special safety equipment should be required.

(3) No portion of the propulsion system should contain hazardous devices of any kind. Certain exceptions to this rule might be taken to include category B electro-explosive devices such as pyrotechnically operated valves.

(4) No portion of the propulsion system should be pressurized or become pressurized even remotely while the satellite is on the ground, during powered flight or during astronaut activities in orbit, including those conducted to separate the satellite from the Shuttle.

(5) No portion of the propulsion system should be susceptible to damage due to the environment of the Cargo Bay during powered flight or in orbit prior to or during separation of the satellite.

The Radio Amateur Satellite Corporation (AMSAT), having had practical experience with both liquid and solid propulsion systems on board low cost satellites believes that the above requirements will prove to be virtually mandatory for low cost payloads flown by the Space Transportation System. Two methods have been considered for some time by AMSAT that appear to meet the above five conditions and produce satisfactory performance for space applications. Both involve using water as a fuel and both have been considered by other groups from time to time as methods of space propulsion.

PROPULSION VIA WATER ELECTROLYSIS:

The propulsion of a space vehicle via hydrogen/oxygen fuel produced from the electrolysis of water is far from a novel idea. Hughes Aircraft Company, Space Systems Division documented the results of an internal research and development IR&D project which developed a working model of a water electrolysis rocket during the first half of 1964 (1,2,3,4). Using this technique a single pressure vessel acts as storage for the water and electrolyte, as an electrolysis chamber and finally as a pressure bottle for the combined electrolyzed gases. The premixed gas may be fed via a single line into the injection chamber of a small rocket engine or thruster. In their final report on this technology Hughes stated, "The Water Electrolysis Rocket has been explored in sufficient depth to verify the feasibility of the concept. Furthermore, it has been determined that this system offers significant advantages over other presently available reaction control systems. Among these advantages are:

- (1) Higher specific impulse
- (2) Lower system weight
- (3) Lower power requirements
- (4) Extended life in space
- (5) Improved system reliability
- (6) System simplicity

(continued on page 17)

(continued from page 16)

It is interesting to note that at the time of the writing Hughes did not consider the safety advantages of the system which are of prime interest to AMSAT. The specific impulse of a small electrolysis motor of the type required for a low cost satellite mission is between 330 and 360 sec. This is considerably better than either an equivalent solid or bipropellant liquid motor system (270 and 305 sec. respectively). Preliminary investigations by AMSAT suggest that the power required to electrolyze one kilogram of water is approximately 5,000 WH.

It is not known why Hughes did not continue to develop this technology to the point of commercial introduction. Clearly, however, mono-propellant hydrazine systems replaced other methods for reaction control starting about the same time as the Hughes research on water electrolysis motors. Since this work was done there have been dramatic improvements in both electrolysis electrode and thruster technologies. AMSAT has also conducted preliminary studies on an advanced method of drying the hydrogen and oxygen gas which should lead to improved thruster performance. This was one problem reported by the Hughes research team.

PROPULSION BY STEAM EXPULSION:

A second method of exploiting water as a safe propellant is by means of a small steam engine integral to the thruster in a water fed propulsion system. Water is allowed to superheat in a small chamber adjacent to an expansion nozzle. Thrust is produced by the acceleration of water molecules as they exit the nozzle. The specific impulse of this technique is far poorer than the electrolysis method (107 sec.), however, the system complexity is very low indeed and the energy required to liberate a kilogram of water into steam is only 750 WH, considerably less than with electrolysis. The specific impulse for a motor of this type can be shown to be governed by the equation:

$$I_{sp} = \sqrt{2 C K T_b (1 - \frac{P_{exit}}{P_{chamb.}})^{n-1} / (C-1) n m}$$

$$\left| \frac{2 C K T_b (1 - \frac{P_{exit}}{P_{chamb.}})^{n-1}}{(C-1) n m} \right|$$

where:

- C = Heat capacity of propellant
(water = 1.3)
- K = Boltzman Constant
(1.38E-23 J/K)
- T_b = Gas Temperature
(approximately 400K)
- n = molecular weight of propellant
(water = 18)
- m = mass of a hydrogen atom
(1.66E-27 Kg)
- P_{exit} = Nozzle exit plane pressure
(assumed = 0.01 Bar)
- P_{chamb.} = Thruster chamber pressure
(assumed = 5.0 Ba)

As can be seen, the specific impulse depends inversely on the molecular weight of the fuel used, taken to the 1/2 power. This favors the use of low molecular weight fuels. As can be seen water is nearly optimum for an engine of this type particularly when the other physical properties of this fluid are taken into consideration in a practical system.

While, on balance, a system using steam as a propulsion technique is far from optimum with respect to Isp it is simple enough to be included on even GAS CAN mission and can solve a reasonable number of propulsion problems for small spacecraft. Figure 1 reviews the performance of this system for a variety of missions of interest to AMSAT and gives a comparison to the electrolysis method.

ORBIT CORRECTION TECHNIQUE USING WATER PROPULSION METHODS:

A salient characteristic of both propulsion techniques reviewed is that they take electrical energy from the solar arrays of the spacecraft and convert it into potential energy (either in the form of stored gas to be burned or in the form of stored electrical energy). Thrust is best produced in a burst mode rather than with a continuous firing. This is a typical operating mode for a reaction control system (RCS) but is somewhat unusual for an orbit transfer maneuver. In effect, time is traded against the burn duration (power production rate of the satellite) so that a reasonable compromise for the total duration of the propulsion phase of the mission is reached. An important consideration for such a mode of operation is that the total delta-V achieved per day during the maneuver must be greater than the deceleration per day due to drag in the Shuttle base orbit. The orbit transfer strategy for circular orbits with a spinning spacecraft is shown in Figure 2. Two small thrusters at either end of the satellite are employed. Firings always occur at the line of apsides. Alternate thrusters are used so that a first firing occurs at perigee thus raising apogee and a subsequent firing occurs at apogee now raising perigee. Mini-Hohman transfer maneuvers are repeated until the desired circular altitude is reached. Elliptical orbits can be achieved with a single thruster fired at consecutive perigees thus continuously raising apogee. Inclination changes with this technique are also possible and are most efficiently applied when apogee also coincides with the ascending node of the orbit.

SUMMARY:

The techniques reviewed have been considered in the past by space research projects and by commercial spacecraft manufacturers. While these propulsion technologies have never been reduced to commercial practice, sufficient study has been done to verify their applicability to space missions. If the STS is going to fulfill its mission as a launcher for ALL space interests then some acceptable methods of propulsion must be found for smaller payloads. These methods must take into consideration the low cost nature of such projects and the very stringent safety constraints imposed by NASA on all STS users. In view of the above AMSAT believes that water propulsion technologies should be revisited because they have the potential of solving the "Shuttle Dilemma" for a class of users that can bring significant benefit to the space program as a whole.

REFERENCES:

- (1) Newman, Daniel D., Study of the Water Electrolysis Propulsion System- Final Report, Engineering Record No. 151, Hughes Aircraft Co., S.S.D., Propulsion and Power Systems Laboratory, 5 June 1964.
- (2) Water Electrolysis Rocket, Hughes Aircraft Company Proposal, 63H-7438/9419 (Dec. 1963).
- (3) Electrochemical Service Unit, Hughes Aircraft Company Proposal, 64H-2115/A3951-001 (April 1964).

Thoughts On Level Three

by Lynn W. Taylor, WB6UUT

Yea, from the table of my memory
I'll wipe away all trivial fond records.
-- Hamlet (Act I, Scene 5, line 98)

According to the ISO Open Systems Interconnect model, the network controllers are responsible for the first three of the seven protocol layers in a packet switched network. Layer 1, the Physical level, is responsible for the physical aspects of communication (radios, modems, HDLC, baud rates). Layer 2, the Data Link level, is responsible for taking the physical medium and making it error-free, and dividing it up among the users. The third layer, called the Network, or Communications Subnet level determines the host-subnet interface and how packets are routed in the subnet. Levels 4 through 7 deal with issues that are beyond the scope of this paper.

Routing is one of the key issues when defining a Communications Subnet Level protocol. The various routing algorithms can be divided into two categories, centralized (where some central station must know or discover the network topology, and serve as a clearinghouse for routing) and decentralized (where each TNC can handle at least part of the routing task). Centralized algorithms must be designed to recover when the master station crashes, and each station must know how to reach the router itself. Decentralized algorithms require each station to know how to pass traffic to other stations in the net; to accomplish this, the TNC needs to find out something about the network topology.

I am going to discuss two specific routing algorithms, the advantages and drawbacks of each, and why I believe we should select a decentralized algorithm for Amateur use. None of this material is original, and most is discussed at some length in the computer science literature. Some of the combinations of this information are new, particularly as they relate to the specific problems of Amateur usage.

The first algorithm has a couple of advantages, and one major disadvantage. This algorithm does not require any special knowledge of the network topology, other than a list of stations that the TNC can hear. When the TNC receives a packet addressed to someone other than itself, it simply passes it on to everyone it can hear except the station it received it from. The algorithm is appropriately called Flooding.

Flooding is easy to understand, and easy to implement. The problem comes when the load on the network increases. Since each packet will pass through every single node in the network, and many of them more than once, the amount of traffic generated by simply saying "Hi" can be staggering. Also, steps must be taken to prevent packets from looping forever through the network. The simplest case of this is a 4 station net (A, B, C and D) where all 4 stations can hear each other. If A originates a packet for D, it passes it to all 3 stations it can hear. B passes it to both C and D, where D accepts it, and C passes it to A and D. D has already got the packet and ignores the duplicate, while A passes it to B and D. Again, D discards it, and B passes it around. At the same time, packets are flowing in the opposite direction around the same loop. While this simple case could be easily fixed, it becomes more complex in a larger net. One solution is to limit the life of any given packet to a certain number of hops, but this still generates a lot of unnecessary traffic.

A better algorithm would require each TNC to have a table giving the address of each node in the network, some measure of the distance to that station, and the address of the next station along a path to that station. A hypothetical 5 station net, and each node's tables is shown below:

```
A <----> B <----> C <----> D <----> E
B 1 B   A 1 A   A 2 B   A 3 C   A 4 D
C 2 B   C 1 C   B 1 B   B 2 C   B 3 D
D 3 B   D 2 C   D 1 D   C 1 C   C 2 D
E 4 B   E 3 C   E 2 D   E 1 E   D 1 D
```

In this example, the available communications paths are shown by arrows (i.e. A cannot communicate directly with C). Note that each station knows how far away all the other stations are, and who is the next station in the chain. If A wants to talk to D, A knows to pass traffic to D, and it will take 3 hops to get there. It is up to B to know who to pass these packets on to.

The problem with this method is easy to see -- where do these tables come from? In the proposed WestNet protocol, which defines a long-haul network for linking geographically separated LANs, a similar algorithm is used which assumes all nodes internal to the network will stay on. In other words, this network is static (because all the nodes are dedicated devices to be installed on mountaintops). In a local network, stations (nodes) tend to appear and disappear frequently.

In a dynamic network, the answer to the question must be "from the network itself." This further divides into two problems: how does a new station get it's initial table, and how do we make sure the table each node has is up to date. To clarify this problem, lets add station F to our earlier network:

```
A <----> B <----> C <----> D <----> E
|                                     |
|-----> F <-----|
```

In this example, A should now pass traffic for E through F, while traffic for D can follow its previous route, or as efficiently through E and F. If all stations listen for new stations on the air, and F comes on and sends an "I'm here" (or CQ) packet, A and E can detect F's presence, connect with F to make sure they can communicate, and pass copies of their routing tables. By taking the best information from both tables, F can build it's initial table:

```
A 1 A
B 2 A
C 3 E
D 2 E
E 1 E
```

There are two equally good paths from F to C (through E and D, and through A and B), F selects these at random.

Also, the rest of the net need to be told about the new network topology. First, A (and simultaneously, E) tells everyone it can hear that F is one hop away from it. B checks it's routing tables, decides that this is good news, and passes the news along to everyone it can hear, etc. This is the flooding algorithm again, with a twist; stations only pass on good news, so if a station

(continued on page 19)

(continued from page 18)

already has a path of length N, it only passes on news of a path of N-1. In other words, when B announces to A and C that "I'm 2 hops from F", C is glad to hear, while A could care less, since A is only 1 from F, while C didn't even know F existed. C will wind picking the first path to F it hears about, since it has 2 paths of length 3 to F. This also means that C might use a different path to F than F would use to C; this does not matter since each have the same length.

F would also pass on the news of it's complete routing able, since the whole table is news to it. This way, A learns of the new path through F to E and E learns about it's new paths. The new tables would look like this:

B	1	B	A	1	A	A	2	B	A	3	A	A	2	F
C	2	B	C	1	C	B	1	B	B	2	C	B	3	D
D	3	B	D	2	C	D	1	D	C	1	C	C	2	D
E	2	F	E	3	C	E	2	D	E	1	E	D	1	D
F	1	F	F	2	A	F	3	A	F	2	E	F	1	F

```

A <----> B <----> C <----> D <----> E
|
|-----> F <-----|

```

```

A 1 A
B 2 A
C 3 E
D 2 E
E 1 E

```

Adding a node to the network is easy compared to what happens when a node leaves the net. Having a node tell the net it's leaving is impractical, because that node may not be able to tell the net because of hardware failures, power failures, or propagation changes. One solution would be for a node to report to the rest of the net that node X is unreachable whenever it can't pass traffic on to X. This bad news would be passed through the net until it reaches X, which would then tell those stations it can still reach that it is indeed still reachable, generating a new set of entries in the network tables.

As an example, A is passing traffic for E through F when F goes off the air. A, realizing that it can't pass traffic through F announces to B that E is unreachable. B passes this news to C, who passes on to D, and eventually to E. At this point, E has been erased from everyone's routing tables. E would then tell D "I'm still accessible", D reports to C that "E is still 1 hop from me", and the good news passes through the net (and contradicts any bad news still circulating). A may now use the longer path through B, C and D, and the network has recovered from the loss of the path to E through F.

The problem of updating the routing tables is the most serious drawback of this algorithm, and I am not suggesting that the method I have explained above is the best. In Computer Networks by Andrew Tannenbaum, he points out that "good news travels fast" while bad news may take awhile to propagate through the network, especially where looped paths exist. By completely eliminating a station from the network tables and re-inserting it, many of these kinds of problems may be avoided.

I have explained two decentralized routing algorithms. These algorithms allow the nodes themselves, on an equal basis, to decide how to route data in the net, and dynamically alter the routing when the network composition changes. What are the problems involved in a centralized algorithm?

Centralized algorithms require a single station to have complete knowledge of the network. To do this, the master station must probe the network, and pass on it's discoveries to the rest of the net. The master must either be a unique station type, or, in a homogeneous network, a station must be selected to be the master. A new station, when it comes on the air, must be able to tell the master it is on, and, if it can't reach a master, would most likely become one. Problems exist, in the case of two networks "growing" together (more than one master), and when the master fails. Depending on the implementation, a network may continue to operate without the master based on old information the master distributed, or collapse when the master disappears. Either solution would be undesirable.

I have shown that a properly designed decentralized system will not suffer unduly from the loss of any single critical station, and recover from the loss of any node in a reasonable manner. Centralized systems rely on the master station discovering the complete network topology, finding changes due to propagation, etc. and distributing this info. Since Amateur packet nets are very dynamic, it is probable that the master will be lost, causing the net to crash, or continue on without any direction.

While I feel the decentralized approach is best, the possibility of reasonable mechanisms for operating centralized networks, hybrid networks, rings, token passing schemes, and others are all worth investigating. My main purpose is to serve as a catalyst for further discussion.

★★★★★

"Join The Packet Revolution" has been our slogan for some time and most of you are now a part of that revolution. How do we know? Chuck Green, NØADI, reports that he just put serial number 1417 on a TNC PC board!

A revolution requires people dedicated to a cause; we have that. A successful revolution requires a growing number of people supporting that cause. It seems to us that the above number is a good indication that we also have that!

Have you noticed an increase in Packet activity in your area? Many areas of the country are experiencing a rapid growth rate. More and more people are asking "what is Packet Radio?" or "what is that abrasive sound?", etc.

An increasing amount of coverage in the national Amateur Radio publications has also heightened interest. Many local clubs are looking for people who know what Packet Radio is to give a demo and/or presentation at a regular meeting. Why not take your packet station to a local club meeting (clear it with their program chairman first) and give a demo? It is even more effective if you take two stations although a pre-arranged sked with someone at their home QTH is good.

Digipeating through another station back to yourself, although not very practical in normal situations, makes for an interesting demo of digipeating. There are lots of other interesting ideas for demos that I am sure you can think of. You will find that a simple demo and/or presentation on Packet Radio will quickly result in requests for more. You will also find that the result will be an increase in Packet Radio activity in your area.

If you do plan such an activity, write TAPR well in advance so we can send you some literature to give those who show interest. We hope you will give this a try, it really is a lot of fun.

Satellite Coordination

A meeting of many of the national groups interested in the construction of amateur satellites was held during the period June 30 through July 3 at Hotel de la Bere in the vicinity of Cheltenham, England. In attendance were the following invited representatives: Ian Ashley ZL1AOX, Dick Daniels W4PUJ, Robin Gape G8DQX, Bandi Gschwindt HA5WH, Werner Haas DJ5KQ, Gordon Hardman KE3D, Phil Karn KA9Q, Jan King W3GEY, HansPeter Kuhlen DK1YQ, Karl Meinzer DJ4ZC, Harold Price NK6K, Randy Smith VELSAT/VE6, Martin Sweeting G3YJO and Dave Woodhall ZS6BNT. Not in attendance were invited representatives from the technical groups of JAMSAT and RACE.

On the agenda were the following main items:

- (1) Review of AO-10 performance and future scheduling of spacecraft operations.
- (2) Review of the PACSAT mission.
- (3) Review of the UO-11 spacecraft status.
- (4) Review of the Ariane-4 launch opportunity.
- (5) Review of new technologies required for future amateur satellites.

Due to the final orbit obtained by AO-10, a set of operating procedures were required that would deal with the upcoming eclipse and sun angle constraints expected over the next two year period. The schedule selected is responsive to the reduced power per orbit and the requirement to off-point the satellite from its optimum attitude in order to minimize thermal and power effects caused by poor sun angles. At the same time attempts were made to respond to a variety of user operating requests.

A modified general beacon (145.812 MHz) schedule was also adopted the more equally shares time between Morse code, 50 baud RTTY and 400 BPS PSK telemetry and reduces the time between successive transmissions of any type.

The details of these schedules will be announced by usual amateur satellite society sources within the next few weeks. They will be in effect by early August as this is the time required to finalize the spacecraft maneuver and implement the needed software.

Regarding future changes to the satellite's schedule, the amateur satellite technical group present adopted the following proposal for review and adoption by the world wide amateur satellite societies:

PROPOSAL FOR THE FORMATION OF AN INTERNATIONAL AMATEUR SATELLITE SERVICE COORDINATION COMMITTEE.

This group, recognizing that:

- (1) The launch of a satellite system represents the creation of a significant resource for the use of all radio amateurs;
- (2) The mission requirements of the groups providing a new satellite system are of primary importance;
- (3) The operational aspects of the amateur satellite service must be carefully identified, planned and managed; and
- (4) The freedom of the individual national and international groups to negotiate and plan new missions independent of external constraints must be maintained,

Proposes the formation of an international amateur satellite service coordinating committee, whose mandate shall be to:

- (1) Establish technical and operational standards for the amateur satellite service;
- (2) Plan and coordinate the orbital operations of each portion of a system which may be released by the groups which launched the system; and
- (3) Interface with the International Amateur Radio Union to ensure that the best interests of all radio amateurs are given due consideration in this planning process.

And further proposes that membership in this committee be limited to those groups who have as a primary interest the provision and utilization of amateur satellite services, as evidenced by their charters or constitutions, and to such further groups as the committee shall determine advisable.

No decisions regarding PACSAT were taken by the assembled group. Considerable discussion was held concerning the need for coordination of packet radio standards world wide. Considerable concern was raised that the JAS-1 packet experiment is unlikely to be compatible with the PACSAT standards on the basis of data rate and modulation type. In general, it was felt that more work was necessary to adopt true international standards for this mode of communications.

No decisions regarding UO-11 were taken by the assembled group. M. Sweeting reported that the spacecraft would be put into service and the experiment program initiated as soon as the boom deployment was complete which was expected in approximately two week's time. [Boom was deployed successfully 27 July.--Ed.]

The Ariane-4 launch opportunity was reviewed. ESA has offered AMSAT-DL a firm launch contract for 290,000 European Accounting Units on the Ariane-4 test launch. The contract is expected to be signed in late July.

Three candidate missions were discussed. These included an Astroid encounter probe, an advanced Phase-4 satellite system concept and a modified Phase-3 satellite. The first two candidates were given lower possibility of success due to time and fiscal constraints. This is particularly true due to the high launch cost being imposed by ESA on this launch. The Asteroid encounter probe was not discussed further. The Phase-4 concept presented by W3GEY was given serious consideration for future opportunities and W3GEY, DJ4ZC and G3YJO will continue to discuss and define this concept.

The Phase-3C satellite to be incorporated on Ariane-4 will contain all of the hardware included aboard AO-10 but with the following additions or modifications:

- (1) A modified kick motor using a plasma propulsion technology.
- (2) A modified Mode-L transponder with improved efficiency.
- (3) An S-Band beacon experiment.
- (4) A packet radio and beacon unit.

The latter unit will be a store-and-forward device with approximately 1 megabyte of memory. In addition, it may have a mode of operation allowing straight regeneration of data as would be

(continued on page 24)

Hams In Space ...

Apparently the Hams-In-Space theme will have periodic reprise throughout the second third of the decade as NASA has selected Dr. Ron Parise, WA4SIR, to fly as Payload Specialist on at least 2 future shuttle missions!

Ron was notified on 11 Jun 84 of his selection. In an exclusive interview with ASR last week, Ron indicated he had applied for the position in Sep 83 and was delighted at his success. He is anxious to include Amateur Radio activities in the mission although he cautions, "This will be a crew-intensive mission" referring to the projected March 1986 planned launch of Mission 61F. The 61F mission will be a further flight of the Spacelab series.

Dr. Parise is an astronomer with a PhD from the University of Florida (1979) and is 33 years old. He has been a licensed amateur since he was 11 having held prior calls WNBJBR and WAGMHD. Ron is a native of Warren, Ohio, is married and has a young son. He and his wife, Cecelia, are expecting another child.

The newest astronaut-selectee is employed by Computer Sciences Corporation in their Systems Sciences Division and currently lives in Silver Spring, Maryland not far from AMSAT Headquarters. Ron is an active AMSAT member and frequently gives talks and presentations on science aspects of OSCAR. He has been AMSAT's Science Coordinator for the UO-9 mission. Computer Sciences is under contract to NASA and in fact Ron works at the Goddard Space Flight Center at Greenbelt, Maryland.

The 61F mission will carry the ASTRO 1 experiment in its Spacelab section. This experiment is sponsored by NASA's Office of Space Science Applications and involves an ultraviolet imaging telescope. Ron helped design the instrument and will be aboard to operate it and collect data. He also is involved in two later follow-on experiments known as the "Hopkins Ultraviolet Prime Focus Spectrometer" developed in conjunction with Johns Hopkins University and the "Wisconsin Ultraviolet Photo Polarimeter" developed in conjunction with the University of Wisconsin. ASTRO 2 (Hopkins Spectrometer) is due for launch in Nov 86 while ASTRO 3 (Wisconsin Photo Polarimeter) is slated for Jul 87. Ron indicates his contract with NASA calls for him flying two missions and being a backup for the third.

Regarding his operating Amateur Radio from the shuttle Ron says he is "enthusiastic" and looks forward "to bringing some radios aboard". Ron says he will support proposals to NASA for Amateur Radio activity on the missions he will be flying but because of intense preparations for the science aspects of the mission, will be unable to spearhead the proposal effort. He indicates full support for the premise without hesitation, however.

The Amateur Space program has its roots firmly planted in space science. AMSAT is a remarkable alloy of scientists, engineers, educators and layman reflecting the very best in Amateur Radio. We are justly proud that "one of our own" has been selected to carry space science further along new paths and will be carrying Amateur Radio along just to keep in touch! Congratulations to Ron, WA4SIR! (And to us, too).

Dr. Tony England, W0ORE, is due to fly the shuttle in March 85 and an ambitious proposal was jointly submitted by ARRL/AMSAT recently to permit Tony to follow the lead of Owen Garriott, W5LFL, and Owen's historic 1983 premiere Ham-In-Space effort.

★★★★★★

JAS-1 Update

JAS-1 is now in its EM/PM phase. JAMSAT has to complete FM #1 modules by the end of August (this year!), when NEC will commence tests to see if JAMSAT made units fit to "buss" of the satellite they produce. Final acceptance test including thermal vacuum test is scheduled in February next year. Test for FM #2 will be some six months later.

JAS-1 makes use of the only micro-computer system in it as IHU as well as PACSAT like "flying mailbox".

JK1VXJ successfully made "no ROM bootstrap loader" for NSC-800 up and running late in April. It was a great milestone for us, since we had regarded that the most critical-path in development of the micro-computer system of JAS-1.

We have received PCBs of the memory system for FM#1. They will be populated shortly. 48 chips of 256K DRAMs will be put into 1 flight model. We have mostly completed series of radiation tests on NMOS (256K DRAM) and high-speed CMOS. The former survived well up to 5000 RADS. In fact, we can't tell "radiated (5000 RADS)" chips from "new" ones. It was beyond our expectation, or imagination. On the other hand, some high-speed CMOS devices were found "dead" at 5000 RADS.

These results made us worry a bit. Design of anti-radiation system in JAS-1 was based on our belief that the most fragile component should be N-MOS DRAM, not high-speed CMOS. DRAMs were "expected to die" at around 1000 RADS.

It was made clear that high-speed CMOS or NSC-800 (which is said to die at around 500 RADS) needs more shielding than DRAMs. In order to give longer life to JAS-1 than previously planned, we decided to change the measure of selective-shielding on chips of these types.

A semiconductor designer in JAMSAT was also surprised at the results mentioned above. Per his request we made another series of radiation tests on 18 NMOS DRAM chips, up to 50,000 RADS. We'd soon know their real break-down point. The result of these tests would be of some use for PACSAT and Phase-3C, which might also employ NMOS DRAM of this sort.

Development of H-1 rocket has been paving the way as expected. There should be no delay of launch, which is expected to be on 4th. February 1986.

A potential "source of problem" (which I personally suppose to be) stems from the failure of BS-2a, our initial DBS for public on 12 GHz. It was launched in February this year. As you might have known, two (out of three) TWTs in that satellite have gone out of order within three months. Our national broadcasting organization was hence obliged to commence the service only with one channel instead of two.

Because of nature of the failure, they now seem reluctant to launch its back-up satellite of the same design (including Thomson-CSF made TWTs) as scheduled in August next year. If they want to postpone the launch in order to make some modification, (since we can only launch satellites twice a year, in February and August) there is a good chance that the launch of BS-2b would be made in February 1986.

In that case, demonstration flight of H-1, which will put JAS-1 into orbit should be delayed. NASDA can not prepare two launchers (N-II for BS-2b and H-1 for JAS-1 in this case) for the same period.

★★★★★★

Packet - A Software Approach

by Bob Richardson, W4UCH

Writing a squib about the software approach in the Tucson Packet Status Register is much like the Little Red Hen's acceptance of Brer Fox's invitation to dinner. There is no question that it will be an outstanding gourmet meal. There is little doubt as to exactly what the intended entre will be. I am unsure whether to feel like the Little Red Hen or a wolf in a chicken feather suit. No never mind, let's press on.

Seriously, packet radio is a house of many mansions. There is room for all types and varieties of radio amateurs from those who like to grind their own crystals (and mine their own galena), up to and including those who prefer to purchase one of Mike Lamb's (Advanced Electronic Applications, Inc.) superb factory built and tested PKT-1 packet radio controllers (from the TAPR design). Let me tell you about the joys of the "mining galena" approach to packet radio. Really, it is not quite as fundamental an approach as all that since we will be using a store bought Model 1, 3, or 4 TRS-80 microcomputer and we will not reinvent the wheel by recasting in silicon the EXAR 2206/2211 AFSK modulator and demodulator chips.

In late 1981, early 1982, we became fascinated with the packet activity of our Canadian Cousins across Lake Erie from our QTH in the southwestern corner of New York state. With two 22 element Cushcraft Boomer 2 meter antennas we were able to copy southern Ontario packet stations running the Vancouver protocol about 75% of the time with S5 or better signal levels. Considering the distance involved was is in the 80 to 120 mile ballpark, a bit of "knife edge" refraction was thrown in to help as most VE3 stations were running about 10 watts to omnidirectional antennas.

Since we had just finished writing a series of textbooks on the software approach to Morse, Baudot, and ASCII teletype programming, it was not too surprising that the idea of using the software approach for synchronous 1200 baud packet occurred to us. With the encouragement of that packet pioneer, Stewart Beal, VE3MWM, and umpteen phone call arranged schedules, we were able to develop a program that emulated in software most all of the features of the Vancouver terminal node controller at 1200 baud. It was a step by step process and consumed all of 1982 to complete the first packet software program. Our good friend, Gil Boelke, W2EUP of GLB Electronics joined the fray on New Year's Day of 1983 and from there on, our weak signal and fading problems were over as Gil is only about 50 miles distant, just south of Buffalo, NY.

The March 1983 release to the public of the AX.25 protocol was greeted with the same enthusiasm by many Vancouver buffs as bubonic plague. Many have still not fully recovered. Also, our software approach was greeted by many hardware approach buffs with similar enthusiasm at the 2nd ARRL Amateur Radio Computer Networking Conference in San Francisco during March 1983. So, what else was new?

The logic and beauty of the AX.25 protocol grows on one if one is willing to keep an open mind and look at the woods as a whole while ignoring the few brambles amongst the trees. We became a born again AX.25 zealot shortly after the San Francisco unveiling and began writing Volume 2 of the software approach - AX.25 protocol the summer of 1983. With the constant aid, abatement, and almost daily testing with W2EUP we were able to finish Volume 2 by year end, 1983.

Volume 1, Vancouver protocol, worked quite well, but had two serious drawbacks:

1. The cyclic redundancy check (CRC) was an almost exact software emulation of the IBM SDLC CRC which was done using the bit by bit approach and when long multi-frame packets were received, one or two of seconds of delay was required to accomplish the CRC check.
2. The received data was stored in memory on a bit per byte basis which was a great teaching tool; i.e., using the edit/modify mode one could display a 1024 byte screen of memory and see the flag bits, data bits with zero insertion where applicable, and closing flag(s). This was delightful, but consumed precious memory like a monster

In Volume 2 we overcame these drawbacks. The first was overcome through the help of Aram Perez who published the "Byte-wise CRC Calculations" paper in the June 1983 issue of the IEEE Micro Journal. By modifying this program for the CRC polynomial used by both the Vancouver and AX.25 protocols, the CRC check was speeded up an incredible 27 times faster than our bit per byte original approach. The second drawback was overcome by using W2EUP's brilliant real-time synchronous to 8 bit parallel byte conversion subroutine with a few of our own modifications. Only the converted data bytes between flags were stored in memory along with the last opening flag and closing flag MEM locations for each frame. The memory monster had happily evaporated into thin air or gone wherever scrolled off bytes go.

Volume 2 - AX.25 protocol first printing was shipped in January 1984 and received a kindly write up in the February 1984 QST. The QST write up plus our overseas distributors' good efforts in advertising gave it the kick off impetus any new book on such an esoteric subject sorely needs.

The 3rd ARRL Amateur Radio Computer Networking Conference was held in Trenton, NJ during April 1983. The conference proceedings include 35 pages of our software approach subroutines and is available from ARRL for \$10 postpaid if you want a truly inexpensive introduction to the subject. Other papers by many TAPR, AMRAD, et al friends, are well worth reading too. If you do not have a copy of the proceedings, you should order one from ARRL.

Volume 2 - AX.25 protocol second printing was received from the printer during July 1984. Its claim to fame, other than having obvious typos corrected, is an additional 32 page Appendix 7 added that covers:

- Overlapping WINDOWS over the main menu a la this rather popular feature on some computer programs that seem to be taking the world by storm. It does not make the program run any better, but it sure looks nice and misleads the reader into thinking we know what we are doing.
- Multiple repeater input if desired. Up to 100 repeaters may be input if this feature suits your fancy. Conversely, up to 100 repeaters in the extended address field are automatically decoded and forwarded if your call and SSID are there.
- Optional automatic beacon mode in addition to the optional auto connect/disconnect mode. This idea is a direct steal from 'TAPR' and a nice to have feature. With both the beacon & auto modes toggled 'ON', the program in your absence will

(Continued On Page 23)

TAPR

Official Supplier of TNC's To The 1984 Olympics

by Ted Harris, N6IIU

The 1984 Olympic Soccer matches were the first use of Packet Radio during an Olympic event. The Olympic Committee wanted delivery of phone messages over a two mile distance.

The Palo Alto Chapter of the Red Cross was already involved with the Olympics and decided to help solve the problem. When the subject of hard copy messages via a radio circuit was discussed loud cries of; "we don't know how to run computers," "we don't want a complicated system," and "how much will it cost" were heard. When told

this was a free experiment, they seemed resigned to the willingness of this group of radio amateurs to do anything to solve problems.

Once installed (and after only short five minute training sessions) the system worked flawlessly until a secretary came over and said, "I thought you said this thing worked. Well it's broken, hurry up and fix it. We depend on it!" The board was swapped and the system returned to 24 hour a day operation for 11 more days. Over 1300 messages were sent with many hours saved.

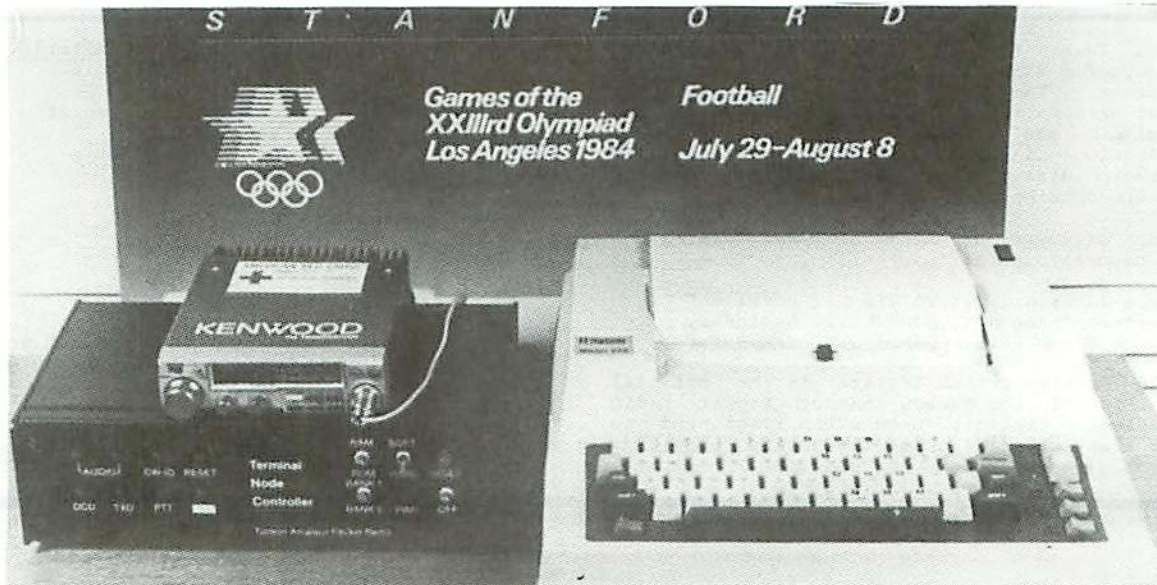

(Continued From Page 22)

transmit "THIS IS WIABC IN AUTO AND BEACON MODE. IF YOU WISH TO LEAVE A MESSAGE, FIRST CONNECT, LEAVE THE MESSAGE, AND THEN DISCONNECT. WILL BE BACK AT 8:30 PM." When NOT connected, the beacon timer will retransmit the beacon message every 5 minutes or at any interval you wish. If someone connects to you in auto mode and is not active for a 5 minute period, the program will automatically disconnect and restart the beacon timer countdown.

- Addition of a simple subroutine for loading the user's call letters into the concatenated program one time only. The permanent program is then dumped to disk one time only. No Gridley, you do 'NOT' have to be an assembly language programmer to use the program, but you MUST know how to insert the disk into one drive and close that disk drive's door. Figure 1 illustrates the main and shift menus of the program without the new windows overlay.

The future of the software approach looks rather promising from three directions.

1. Remote low power repeaters as in satellite or in mountain top repeaters. Using a CMOS version of a Z-80 with CMOS ancilliary chips and memory offers an order of magnitude or more reduction in total power consumption over the hardware approach with its own dedicated packet micro-computer, sometimes called a packet controller.
2. Parallel, data-flow, and/or pipelined non-Von Neuman computer architecture using dual micro-processors on a single chip, but sharing the same accessible though segmented memory, offers

the software approach full duplex operation, if that is your pleasure. The dual 6502 micro-processors on a single chip are now available and the dual Z-80s on a single chip are not too far down the pike.

3. The new Z-800 microprocessor with its built in cache memory and pipelining offers the software approach the capability of running 9600 baud initially with its 10 MHz clock and growing to 19.2K baud in about a year when the Z-800 clock grows to 25 MHz. Incidentally, the only thing better than one Z-800 are two Z-800s. With two of these rascals sharing a single memory, yes it is easily implemented, you can virtually re-invent the world in your own image if you wish. About the only limit is your own imagination.

Want to dig deeper into the software approach? If so, our 280 page Volume 2 - AX.25 protocol is available for \$22 (US) postpaid in the U.S. and Canada from: Richcraft Engineering Ltd., #1 Wahmeda Industrial Park, Chautauqua, NY 14722 or phone (716) 753-2654 for COD orders. For overseas orders and/or forthcoming French and German language editions, write Richcraft.

Here at Richcraft on the shore of beautiful Lake Chautauqua we have the highest admiration for the Tucson Amateur Packet Radio group led by Lyle Johnson, WA7GXD. TAPR's dedicated team has virtually accomplished the impossible with only invisible assets. Nevertheless, those invisible assets of truly hard work, dedication, and selfless contribution to the advancement of amateur packet radio have been of inestimable value and earned the TAPR team the world leadership they so richly deserve.

(continued from page 20)

of use by gateway nodes internationally. The same unit will be capable of using the large memory for storage of beacon messages which will be transmitted in 300 or 1200 bps FSK or PSK. The packet mode is expected to use 2400 bps PSK.

The Phase-3C satellite will be constructed by all of the groups attending the meeting. Work assignments were made so that progress on the new satellite may begin immediately.

A variety of spacecraft technologies were discussed during the last day of the conference. The intent was to identify technologies needed for future amateur satellite missions. Included in the presentations were propulsion technologies, attitude control technologies and improvements in ranging/orbit determination technology.

The Tucson Amateur Packet Radio Corporation is a nonprofit scientific research and development corporation. The Corporation is licensed in the State of Arizona for the purpose of designing and developing new systems for packet radio communication in the Amateur Radio Service, and for freely disseminating information acquired during and obtained from such research.

The officers of the Tucson Amateur Packet Radio Corporation are:

Lyle Johnson WA7GXD ... President
Heather Johnson .. N7DZU Secretary
Chuck Green NØADI Treasurer

The Packet Status Register is the official publication of the Tucson Amateur Packet Radio Corporation. Explicit permission is granted to reproduce any material appearing herein, providing credit is given to the author and TAPR.

It was felt by most of the participants that the meeting accomplished its intended objectives and was much needed. The conference again demonstrated the value of international cooperation and participation as the amateur satellite service matures.

★★★★★★

(continued from page 5)

That's the list as I know it to be. Submit any others to the TAPR PO box. Now that we've got a secretary, hopefully they won't get lost.

Remember, the TRACE command is handy for looking at the protocol and seeing exactly what the TNC sent/received, including user data. Please include hardcopy of traces for protocol error reports.

★★★★★★

PSR Mailing address: (For PSR editorial material)

Minnesota Amateur Packet Radio
c/o Pat Snyder, WAØTTW
University of MN Computer Center
208 Union Street S.E.
227 Experimental Engr. Bldg.
Minneapolis, MN 55455

via CompuServe: 70225,1252

TAPR HF Net:
21.280 MHz 7.158 MHz
1900Z Sundays 2100Z Sundays

The Packet Status Register is edited and prepared by the following members of the MAPR group in the Twin Cities using material contributed from wherever we can get it:

Pat Snyder WAØTTW
Paul Barnett NØCRN

Tucson Amateur Packet Radio Corporation
P.O. Box 22888
Tucson, AZ. 85734

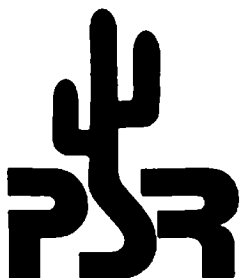

Check YOUR address label for membership EXPIRATION date !