

# Packet Status Register

March 1987 #26



## Tucson Amateur Packet Radio Corporation

### PRESIDENT'S CORNER

Lyle Johnson, WA7GXD

#### Packet and HF

There seems to be a lot of controversy these days about appropriate modem technologies to use for HF packet work.

In this case, fortunately, much of the controversy can be resolved by careful investigation from a technical standpoint.

In the January/February issue of PSR, Dan Morrison, KV7B (who designs modems and other signal processing devices for a living), and Eric Gustafson, N7CL (who is a careful measurer and observer of radio-based phenomena and is an electronics design engineer by profession), reported on some potentially significant findings they reached regarding HF packet operation.

The summary of the two articles includes the following points:

(1) EVERY MODEM TESTED WORKED BETTER WITH A 500 HZ IF FILTER IN THE RECEIVER'S PASSBAND.

This is for a variety of reasons, the most notable being (a) the S/N ratio is improved (b) the passband matches the spectra of the 300 baud 200 Hz shifted packet signal and (c) interfering signals are kept out of the receiver's AGC system.

Note that tested modems included the phase-locked-loop (PLL, in this case the XR2211 found in every TAPR and TAPR-clone TNC), all-digital units (specifically the AMD7910, found in the various Kantronics Packet Communicators) and the filter/slicer types (in this case, the AEA PK-232).

(2) COLLISIONS ARE A MAJOR REDUCER OF THROUGHPUT ON HF.

Collisions are caused when a TNC decides that no other station is transmitting, so it goes ahead. TNCs depend on accurate data-carrier detect (DCD) information from the modem. PLL demodulators are the most reliable providers of DCD related to packet signals, and better able to reject other signals as QRM (eg, foreign broadcast stations on 40 meters).

(3) Extensive testing in a well-documented manner, operating equipment in strict accordance with manufacturer's instructions, has provided evidence that the lowly TAPR PLL modem, when properly adjusted, will outperform any and all Amateur HF packet modems when operated as described in the articles!

(4) A TUNING INDICATOR IS A NECESSITY FOR GOOD HF PACKET OPERATION (not channelized BBS use, but "real Amateur radio QSO" style operation).

The AMD7910 modem does not provide good hooks for such a tuning indicator. The dual-filter type modems usually have such indicators built-in. The TAPR tuning indicator plugs right in to the TNC 1 and TNC 2 (and clones).

(5) ONE OF THE SECRETS OF SUCCESSFUL HF OPERATION IS TO QSY TO A "CLEAR" CHANNEL.

DO NOT TRY TO HOLD A PACKET QSO ON 14.107, or 14.103, or any other busy frequency. Just because packet users CAN share a channel does NOT imply that packet users must share a channel, or even that they should! The "hidden terminal" is a big problem on HF packet due to ionospheric propagation. Clustering on a single frequency will only aggravate the problem.

So, if you want to have enjoyable HF QSOs on packet, rather than endless frustration and more retries than you can easily count, the rules are simple:

- 1) Get a tuning indicator;
- 2) Get a narrow IF filter in your receiver, selectable in the SSB (or FSK) mode;
- 3) If you see a CQ (or send one) on a busy channel, get the other station to QSY to a clear spot BEFORE you exchange name, QTH, etc;
- 4) ENJOY!

Lyle

PS - I'll be talking about HF packet operation, and answering questions about this topic as well, at the Friday afternoon Packet session at Dayton this year. See you there!

- PRM -

TAPR ANNUAL MEETING  
February 21, 1987  
Tucson, Arizona

Reported by Scott Loftesness, W3VS, [76703,407]  
Distributed via HamNet on CompuServe. Distribution  
of this copy via the Amateur Radio packet network is  
encouraged.

### 1. Introductions

Individual introductions were done -- about 60  
people were in attendance at the beginning of the  
meeting with another 20-30 joining later in the day.  
Packeteers from the east coast (Massachusetts,  
Virginia, Florida, etc.) to Hawaii were present at  
the meeting.

### 2. Elections (new directors)

Harold Price, NK6K, and Tom Clark, W3IWI, were re-  
elected to the TAPR Board of Directors. Three new  
directors were elected to the TAPR Board: Dianne  
Marshall, AL7FG; Bob Gregory, KB6QH; and Dave Toth,  
VE3GYQ.

### 3. Officers

TAPR officers for 1987 are:

President: Lyle Johnson, WA7GXD  
Exec. VP: Tom Clark, W3IWI  
Secretary: Dianne Marshall, AL7FG  
Treasurer: Terry Price, N6HBB

In addition, Dianne Marshall was appointed Business  
Manager of TAPR.

### 4. Tribute to Pete Eaton, WB9FLW

(Note: Pete was unable to be in Tucson due to  
illness.)

A plaque was presented by Andy Freeborn to Pete  
Eaton, retiring TAPR board member and Executive  
Vice-President, on behalf of the TAPR Board of  
Directors with the following inscription...

PACKET PETE

During the period of 1982 to 1987 Peter J. Eaton  
made outstanding contributions to the hobby of  
Amateur Radio.

In his position as Executive Vice President of  
T.A.P.R. he was instrumental in guiding many facets  
of development of packet radio during its pioneer  
years.

His unselfish personal sacrifices, dedication,  
technical competence and management abilities were  
of major importance in the development of a new  
amateur communications mode.

Worldwide users of this new communications mode will  
forever enjoy the results of his efforts.

Presented to Packet Pete Eaton on behalf of amateur

radio operators worldwide by the Members, Directors,  
and Officers of Tucson Amateur Packet Radio with  
deepest appreciation.

February 21st, 1987  
Tucson, Arizona

### 5. Packet Radio Magazine - Gwyn Reedy, WBEL

Jan/Feb issue just mailed (will be 40 pages rather  
than 20-24 pages), more packet groups joining and  
providing their local input to the magazine,  
circulation holding steady at about 2,000, still in  
process of applying for 2nd class postage permit  
which will help speed delivery (currently sent via  
third class). Gwyn has not deleted anyone from the  
mailing list yet -- if an issue doesn't arrive, it's  
probably the mail that didn't get through! If you  
don't get the issue, let them know and they can send  
a replacement. Done under the sponsorship of FADCA  
- although separate financially. Bob WA6ERB asked  
what type of input from the clubs was desired. Gwyn  
commented that he doesn't get a lot of specific  
feedback on what people want. People do call if  
they don't get their issues - so they do care about  
getting the magazine. Gwyn added that the size  
limitations (1-2 pages) really make it a place for a  
club to discuss what they are doing and to share  
that with the rest of the packet world. It's not  
especially effective if just directed to their  
particular club members. Gene, KH6PP, asked if  
unsolicited contributions would be welcome. Gwyn  
says yes -- although the problem currently is that  
there is more material available than can be printed  
with the current financial structure. He is  
especially interested in less philosophy and more  
good technical material. A question was asked about  
sending sample copies. Gwyn is willing to do this  
but he can't do so on a free basis (costs over a \$1  
to do so).

### 6. Packet in Government - Al Danis, WA6HGF, Chantilly, VA.

Al shared where the amateur radio contribution has  
gone. Amateurs are clearly leading the way at the  
highest levels of government -- as opposed to the  
usual comments about amateur radio being in the dark  
ages. Al's background is Army communications. The  
link between voice radios used for tactical  
communication and computers has been listening.  
Concerns about monitoring has resulted in voice  
radios moving to digital scrambling -- they are  
digital radios. But can't run standard Bell 202  
modems over these radios - must go in on digital  
ports (typically 16kbps). In the UHF spectrum,  
communications satellites are used but contain high  
noise levels and high error rates. Had to go to  
forward error correction to make effective use of  
these facilities. Also had problems with the  
relatively long delays (satellite, scramblers,  
etc.). "Tempest" requirements to limit RF radiation  
were tough challenges -- requiring placing the  
packet TNCs in hardened steel boxes. Al brought two  
of these Tempest shielded boxes containing TNCs (one  
based on the TNC-1 and the other on the TNC-2). The  
technology is being used to computer communications  
for critical communications within the government.  
Phil KA9Q commented that since the government users

of packet are so grateful, could they exert a little influence with the FCC supporting amateur radio (for example, commenting on the recent 220 MHz rulemaking proposal). The future: ease of use, lighter and smaller units, etc. Al estimated that it would have cost the government \$5 million to have done this development -- if they had even known that the technology was possible/available (vs. paying \$185 for the original TNC-2 that Al purchased). Sell for \$5,000 in quantity 1, 200 units in the field today, expect many, many more to be in the field in the next couple of years.

#### 7. TEXNET - Bill Reed WDOETZ, Dallas TX

(TEXNET is being developed by the Texas Packet Radio Society)

Bill had briefly discussed TEXNET at last year's TAPR meeting -- and a lot has happened in the last year. See the several reports on TEXNET in the December issue of PRM.

#### 8. NET/ROM - Mike Busch, W6IXU

Mike is well known in California for the W6IXU mailbox he operates from Arroyo Grande, California. Mike works with Ron Raikes, WA8DED (Ron is well known for the "DED" ROM's for the TAPR TNC-1). Mike and Ron work together professionally (for their company Software 2000 Inc.) writing professional networking software. They were looking for a break from their commercial activities and decided there was an opportunity to make a contribution in amateur radio networking.

NET/ROM is replacement firmware for the TAPR TNC-2 which transforms the TNC-2 into an NNC. It is designed for hilltop use (not for users at this time) and is intended for use by any AX.25 user station. It supports dual and multi-port nodes. It is written in C providing easy portability. NET/ROM's alpha-test version has been running in California on the 145.01 MHz long-haul digipeaters since January 11th. The beta-test version is scheduled for implementation in late February and will include a 220 MHz backbone plus use of a satellite "wormhole" to Virginia. The first generally available release, 1.0, is planned for general distribution in early April. It will be a commercial product, copyrighted (and not to be copied), and source code will NOT be available. Prices will be \$65 for the initial copy plus \$35 for additional copies for the same callsign owner. Product support will only be available via CompuServe (telephone support will not be available).

NET/ROM was developed to address the serious performance problems being encountered using AX.25 over long paths. NET/ROM implements true store and forward packet switching technology. Mike observed that there hasn't been any significant progress in 3 years, that networking efforts were going very slow and not really addressing the real problems. In addition, there is potential for commercial use of this technology - and amateur use provides an excellent test-bed.

NET/ROM requires an almost off the shelf TNC-2 (32K RAM is required). Running at the higher (4.9 MHz) clock speed is strongly recommended -- especially when running at 9600 bps. An upgrade of U3 is also recommended. A single wire addition is also recommended (it brings out a line from the TNC to a spare line (pin 23) on the RS-232 port).

NET/ROM is designed to be very easy for end-users to learn. A "connect" command is provided similar to that on the base TNC. A "nodes" command identifies nodes on the network. A "users" command (new in the beta version) is also provided which displays everything going on at the node (who's online, who they are talking to, etc.). Additional control operator commands are provided: "sysop" provides support for remote administrators to control a node; a special version of the "nodes" command to permit manual alteration of the network routing tables; a "parms" command is provided to permit the user (sysop) to control detailed parameter changes; an "ident" command permits assignment of a mnemonic code to be assigned to a node.

NET/ROM does include support for existing AX.25 technology including the digipeater functions.

NET/ROM includes automatic adaptive routing. Both manual and automatic updates are done to the network routing tables. A user requests access to a node and NET/ROM selects the "least cost" routing to the node. Dynamic re-routing is also provided -- i.e. a connection will be maintained in spite of a network failure occurs along the way. Nodes can have both callsigns and mnemonic node identifiers -- and the mnemonics can be used as aliases or synonyms for the callsign in any context. The mnemonics are NOT used on the air -- only the callsigns are used on the air.

NET/ROM implements two levels of error and flow control. The normal link layer error and flow control is provided. An end to end flow control at the transport layer is also provided. This is intended to prevent one circuit (user) from "hogging" all the bandwidth. An 8 frame sliding window protocol is used for error control. It implements a selective retransmission facility -- where only the frame in error needs to be resent.

Deferred disconnect logic is implemented in the beta version. It addresses a problem with a disconnect over a long path and handling of inflight information frames. Following a disconnect, NET/ROM will attempt to wait for the all inflight information frames to be received -- or wait for fifteen minutes with no forward progress on the inflight frames.

#### 9. HF Modems - Eric Gustafson, N7CL

Eric has been doing a series of tests to 300 bps, 200 hz shift HF modems (see December '86 issue of PRM for more background). The results were published in the January/February '87 issue of PRM.

Eric's tests indicate only an 8% difference between the best and worst modems -- not a major difference in performance. His tests included the PK-232, the

PM-1, the AMD7910, and a reference demodulator using the Exar PLL chip.

Bottom line: spend your money first on an IF filter for your radio and on a tuning indicator! Modem differences aren't as significant as getting the IF bandwidth down.

#### 10. TCP/IP Networking - Phil Karn, KA9Q

The TCP/IP protocols (also known as the Internet protocols) were developed to unify multiple systems/networks into a single network (from a user's perspective). TCP/IP was funded by DOD and has become a government standard. It also has become one of the defacto standards for commercial networking.

The notion is that network gateways are provided to actually accomplish the network interconnection. The approach has been to pick the least common denominator and use that to implement the network. It provides a uniform addressing scheme independent of any particular subnetwork. Fundamental transmission unit is the "Internet Datagram". IP Datagrams are switched by IP Gateways.

Phil reported on his TCP/IP for amateur application development work.

#### 11. PSK Modem - Tom Clark, W3IWI

Tom has been working on a new 1200 bps PSK modem, designed for use with the Japanese JAS-1 amateur satellite. Tom reported on the design work (which has been completed) and announced that "95% complete (no cabinets or mechanical parts provided)" kits for building the modem will be available from TAPR soon at a cost of less than \$100. TAPR will be making an official announcement about modem availability, prices, etc. shortly.

Tom had a complete demonstration of the modem set up in the meeting room using the two initial prototype units of the modem.

#### 12. TAPR Treasurer's Report - Terry Price, N6HBB

Terry presented the annual treasurer's report for TAPR. 1986 was essentially a "breakeven" year for TAPR with net income amounting to \$1,370.

#### 13. Generic 'C' BBS - Dave Toth, VE3GYQ

Dave and Hank WORLI have been doing development work on a Packet BBS written in a portable development language suitable for porting to a variety of host computer systems. The BBS is getting close to an initial "production" release. Beta test versions have been available in the CompuServe HamNet DL9 Data Library and "testers" have been encouraged to download the code and implement it on their own systems. Feedback on problems and suggestions for improvements are encouraged. The bulk of the work to date has been done on the IBM PC using the Microsoft C Compiler, but additional ports are being done by others for the Apple Macintosh, OS9 and other systems.

#### 14. PAKGRAM - Jay Nugent, WB8TKL

PAKGRAM is a program (written in 8080 assembler running on CP/M) intended to provide easier, automatic, and unattended operation for handling radiograms when sent through packet networks. Jay has defined a standard message definition protocol. Jay gave an update on his activities over the last year.

- PRM -

FCC - continued from page 5.

number of club members, geographical area served. If you are an individual, perhaps your technical qualifications and/or experience will help.

The second paragraph usually sets the stage with background and an outline of your position. Referencing the Known position of others (the ARRL or other organizations) can help to show the unified stance of amateur radio or conversely, the unified stance of the opposition. The argument itself may be part of this paragraph if not too long or may follow in as many pages as needed.

The final paragraph should summarize your position and clearly state what you want the Commission to do. (no, not in those words!) On long documents, you may consider a summary as the second paragraph, with the final paragraph as the suggested FCC action.

Respectfully submitted,

name or name of club

address

Signature and title

date

- PRM -

HAPN - continued from page 6.

3. The instructions will include an updated DISK1 with AX25 software that allows switching between 1200 and 4800 baud under program control.

4. We suggest participants to send a check or money order to HAPN of 50\$CAN or 40\$US for cost of the parts, diskette update, instructions and mailing.

5. For participants returning worthwhile feedback within 8 weeks (10 weeks outside of Canada) we give a 15\$Can (10\$US) refund. If feedback is not received within this time the money will go into the general club funds.

We hope that you can participate and share in the excitement of building something to the advancement of packet radio and your fellow hams.

- PRM -

# Packet Status Register

#27

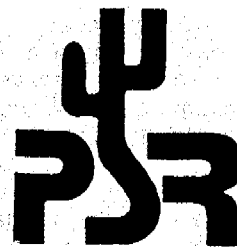

## Tucson Amateur Packet Radio Corporation

### President's Corner

Lyle Johnson, WA7GXD

Although TAPR didn't have a booth this year, packet certainly had a strong presence at the Dayton Hamvention.

AEA and GLB each had prototype units of their new 220 MHz high-speed packet radios.

The AEA unit is synthesized in 5 kHz steps, has adjustable power output from about 5 to 30 watts, and even has a microphone jack for those who wish to operate in analog modes... The demo unit runs at 9600 bps, but an AEA representative stated that the units would be able to run at 19.2 kbps by the time they ship, which was estimated to be sometime in mid-summer. The prototype units at the booth weren't connected up.

The GLB unit, dubbed NET/LINK, is crystal controlled, runs about 2 watts output, and was running data at 19.2 kbps. For the astute observers with high-speed pencils and notepads, the demo units were sending source files for the code in the new PK-2 packet controller...

Not to be outdone by the commercial interests, the GRAPES (Georgia Packet group) guys showed up and demonstrated a 56 kbps system running TCP/IP on 440 MHz. Their design is based on a 29 MHz transceiver and a commercial transverter to go to the band of your choice.

The Technical Excellence Award was given to Hank Oredson, WORLI, for his work in advancing the art of message handling in packet radio. This makes two out of the first four Technical Excellence Awards for packet radio! Unfortunately, Hank was unable to attend the Hamvention, so I stood in for him at the banquet and accepted the award on his behalf. Congratulations, Hank!

The PSK Modem project is about wrapped up for the initial batch of 200 units. Anticipated shipping date is sometime in May, with the first 200 units priced at \$100 plus \$10 S and H in the U.S.A. The price will then be revised to reflect our actual costs (the first units' pricing is based on estimated costs, which are usually lower than the actual costs -- ask any defense contractor...) and the next 200 cranked up for a probably June shipment. Of course, the second batch date could slip if we find any major problems with the first units.

The PSK project has been a pretty intense effort, with Tom, W3IWI, doing the prototype work and then Eric, N7CL, doing four (!) layouts as the design was refined and parts arrived. As of this writing, about 98% of the parts have arrived and the PC house is busy cranking out PC boards. The assembly and test documentation is about 80% completed, and the theory and interface sections of the manual are "in progress."

Shucks, maybe we should adopt the Software Creed, Article V, which states, in effect, that there should be no user documentation. If it was hard to design, it should be hard to use!

The weekend of May 20 the ARRL Digital Committee will be meeting. If you have any inputs for mods to AX25 L2 V2.0, or any other matters you would like considered, please send them in today to either myself c/o the TAPR PO Box, or directly to Paul Rinaldo, ARRL, 225 Main Street, Newington CT 06111.

In closing this month, I would like to point out that we again have the K9NG 9600 bps modem boards in stock at the office, along with plenty of Tuning Indicator kits.

Lyle

- PRM -

### TAPR MEMBERSHIP APPLICATION

Tucson Amateur Packet Radio Corporation  
P.O. Box 22888, Tucson, AZ 85734

Name: \_\_\_\_\_  
Callsign: \_\_\_\_\_ License Class: \_\_\_\_\_  
Address: \_\_\_\_\_  
City & State: \_\_\_\_\_ ZIP: \_\_\_\_\_  
Home Phone: \_\_\_\_\_

I hereby apply for (select one) full/associate membership in Tucson Amateur Packet Radio Corp. I enclose \$15.00 (full)/\$5.00 (associate) for one year's membership dues. I understand that \$10.00 of my dues (full members) is for subscription to PACKET RADIO MAGAZINE (PRM). Associate members do not receive any publication. The entire amount of the associate membership dues and \$5.00 of the full membership dues go to support TAPR's research and development activities in packet radio. My signature indicates that I desire to become a TAPR member and to subscribe to PRM (full members only.)

Signature: \_\_\_\_\_ Date: \_\_\_\_\_

## One Final Editor's Note

In the January/February PSR section of PRM I made some clearly marked editorial comments about technical and user issues in the articles by Eric Gustafson and Dan Morrison. I sincerely apologize to both Eric and Dan for not clearing my comments with them prior to publication. This was a distinct error in judgement on my part during the rush to get the overdue Jan/Feb issue to press. They have both accepted my offer to publish their rebuttal and comments and both are presented below without modification. It is unfortunate that one of them felt the need to use this forum to question my integrity based on his unfounded assessment of my motivations. I'm sorry gentlemen!

Gwyn Reedy, PSR Editor

Editor, PSR:

Please publish this letter untouched or else not at all. In either case, this letter will be posted on CompuServe, timed to coincide with release of the present issue of PRM.

It was with shock and disgust that I read the "editor's notes" that you, as owner of Pac-Comm, wrote at the end of my article and sprinkled liberally throughout Eric's in the January-February issue of PRM. In fact, these self serving, technically incorrect comments were nothing more or less than the squeal of pain by a commercial vendor in response to implied criticism of products he manufactures. Let me address your comments in detail.

1. You state in the first paragraph of the comments following my article, "... For usage on a dedicated packet frequency, or on a multiple use frequency where transmission on top of an existing voice user is undesirable, the user may wish to consider whether detecting only other packet signals is the most appropriate method of operation."

Gwyn, the fact is that there are NO "multiple use" frequencies at any given moment. Either the voice QSO is interfering with the packet QSO or the packet QSO is interfering with the voice QSO. Packet operators shouldn't be operating on top of a voice QSO in progress. If the voice user encroaches on a packet QSO in progress and finds it unpleasant, that's his look out. In the early days of Amateur packet radio there were many experiments carried out on FM voice repeaters to see how compatible the two modes were. The universal response from all voice users knowingly or unknowingly "sharing" the repeater with packet activity was that packet was an unwanted, highly unpleasant form of interference. This feeling continues to this day among voice users, and must certainly be the case on HF, especially 40 meters. Here most SSB operators "sharing the channel" live in South America, and many of them seem totally oblivious to any other mode of operation.

There are only greater or lesser degrees of interference. Under these circumstances, to accept anything less than the best technical means for generating the Data Carrier Detect (DCD) signal serves no purpose except to needlessly increase the

offered load to the packet channel, and to QRM other packet transmissions. The fact of the matter is, the best DCD detectors in current Amateur packet TNCs are the ones based on quadrature detection in a PLL. Envelope detectors work poorly in interference (the norm on 40 meters), and are typically turned down to the point of non-operation.

The jury is still out on DCD derived from the digital PLL in TNC 2's state machine, and I would be very interested to compare its performance to that of the DCD derived from the quadrature detector in the 2211 PLL. I will offer a comment, however. Once the bit decision has been made, as is the case by the time the state machine sees the signal, a lot of information has been lost. An off-the-cuff guess then, would be that it will not be as effective as the 2211 quadrature detector DCD. On the other hand, it is an open question whether the 2211 based DCD, with the commonly used circuits, takes full advantage of the additional information available prior to the bit decision.

2. You mention two reasons for using tones other than 1600 Hz and 1800 Hz for packet modems: to use RTTY filters on packet, and because the Exar 2211 "may perform better with more signal transitions per data bit and a smaller frequency shift." In fact, the 1700 Hz center frequency was picked by TAPR for a very specific reason. It is because 1700 Hz puts the signal close to the center frequency for all the bandpass filters in the signal path in radios normally used for voice. This means that distortion of both phase and amplitude is probably less for packet signals centered at 1700 Hz than for higher or lower frequencies. I use the word "probably" because it's always possible to sell radios with particularly atrocious filters (including audio filters), which operate better closer to a band edge than in the middle of the passband. Hopefully this is the exception rather than the rule. To argue that one should use RTTY TU filters on packet is to argue for sleaze. If the filter-based RTTY demodulator is optimized for its intended mode, it will be far from optimal for 300 baud packet. The incremental cost to add a demodulator tuned to frequencies different from those used on RTTY is small. The fact is that it costs less to use a PLL than the usual complicated collection of active filters, envelope detectors, and slicers found in most RTTY TUs. The PLL also works better, according to the most unbiased and carefully thought out experimental investigations reported to date, i.e., those performed by Eric. Interestingly, the PLL demodulator is the only one which can be retuned easily to ANY center frequency, by adjusting a single pot. (Incidentally, the use of a filter/slicer demodulator in a RTTY TU is perfectly proper, as the data rate is significantly less than the tone separation.)

Your final argument for using a center frequency other than 1700 Hz, concerning signal transitions per bit, simply doesn't work out, although there seem to be several TNC manufacturers who believe this. If the loop filter and post-detection data filter in the PLL are correctly designed there should be little if any difference in error rate performance regardless of center frequency, with the stipulation that the lower tone frequency should not be too close to the baud rate (1600 Hz at 300 baud is perfectly adequate, producing about 2 percent bit

timing errors for high SNR signals). I would be interested to see experimental data backing up claims for improved operation due to an increase in center frequency.

It turns out that there IS one argument for using tone pairs near the the standard RTTY frequencies. Interestingly enough, I have never heard a commercial TNC manufacturer mention this as a reason for using a center frequency higher than 1700 Hz on packet. Yet, it may be the very reason for the original selection of the RTTY tones in use today. The argument is this: For a number of commercial receivers, if you select SSB as the operating mode (thereby setting the BFO offset frequency) and switch in your 500 Hz CW filter, the center of your IF passband will be very near either 800 Hz or the midpoint of the RTTY tone pair depending on which sideband was selected. For those of us with an IF shift control it is no problem to translate this to 1700 Hz, but there are undoubtedly a lot of rigs that can't do this. (It sure would be nice if radio manufacturers stopped dictating how the IF strip is configured based on operating mode, and restored complete flexibility to their products.)

The use of a 500 Hz filter on HF packet makes a dramatic improvement in performance under interference conditions, especially for TNCs incorporating a limiter early in the demodulator. Only Kantronics, to the best of my knowledge, has addressed this point, giving owners of one model TNC the choice of using a limiter or not.

3. The last technical issue you raise in the comments following my article concerns tuning indicators. The fact is, that there are several ways to do it. There's undoubtedly plenty of room for subjective judgements on quality and ease of use. However my (subjective) experience, and that of many people I've talked to on HF packet, is that the single-lit-element design based on PLL loop stress is superior to others in ease of operation (including its use for centering the IF shift when using a 500 Hz filter). It is also easy to implement.

Now I will address the ethics of your position in commenting as you did, Gwyn.

It is conventional and expected in the publishing industry that journal editors will return page proofs or other copy to authors when editorial changes have been made to their articles. If the author differs with the editor, these differences are either worked out or else the article is withdrawn. This has been my invariable experience, regardless of whether I was dealing with scientific or technical journals, or publishing in the Amateur press.

You did not do this. In fact, you did not even indicate to me or Eric that you had done anything by way of altering our articles or injecting your own opinions until the February TAPR meeting. At that time you sheepishly approached us and told us what to expect, as PRM had already gone to press. When you mentioned the content of your notes it became clear that misleading statements had been made, to which we would have strong objection. This is an abuse of your position as designated editor of TAPR's newsletter. As was pointed out at the TAPR board meeting in which it was agreed that PSR move to PRM, the potential for a conflict of interest on your part is ever present. At that time you gave assurances in the strongest possible language that

this would never happen. Well it has happened. I am very disappointed.

Dan Morrison, KV7B

Editor, PRM:

Please publish this letter untouched or not at all. In either case, this letter will be posted on CompuServe, timed to coincide with release of the present issue of PRM.

This letter addresses your editorial comments inserted into my article on HF modem performance in the January-February 1987 PSR which was published as an insert to PRM.

Just prior to publication of my article I received a call from Mike Lamb of AEA indicating that he had heard that I was doing some comparison tests. He asked me to summarize my findings for him and I did so. He was surprised at the results until I told him that all of the testing had been done with a 500 Hz filter in the radio I.F. strip. He then indicated to me that he was concerned that people reading the article might not realize that a narrow filter had indeed been used. I assured him that I had clearly and unambiguously included this information in the text of the article. I told him that I had already submitted the text for publication but had not as yet seen a final version of what would be printed in the magazine after editing. He said that he was concerned that this information might have been edited out and asked if it was ok with me if he called you (Gwyn Reedy) to be sure that the information about the filter used in the radio was indeed included in the article as published. I told him I was sure that you wouldn't edit out as large a block of text as I had devoted to discussion of radio bandwidth, but he was free to call and find out for himself.

At the TAPR annual meeting in February 1987 you approached me and said that you had indeed received a phone call from Mike Lamb at AEA. You said that he told you that I had agreed to the text of a "couple" of editorial comments to be placed in my article. I never entered into any such agreement, and that you would not bother to check with me is shocking, in view of the fact that all these insertions substantially modify or outright contradict points made in the article. Also, I was never given the opportunity to review the comments prior to publication. If I had, I would have insisted that they be removed or I would have withdrawn the article for publication until we could resolve our differences.

Now let me discuss the comments themselves in detail. All but one of these comments is misleading and obscures the clear technical points I was trying to make in the article.

Ed Note #1:

"Most CW filters are extra cost options and therefore may not be installed in many transceivers if the owner is not interested in optimum CW performance. Properly adjusting (or modifying) the radio to center the filter over the packet signal requires skill that new packet operators may not possess. Therefore audio filtering on the TNC device may be the best approach for commercially produced TNCs."

I am concerned that although not explicitly stated, the implication of this editorial comment is that a filter at audio is an acceptable alternative to having a filter of appropriate bandwidth in the radio. The plain fact is that this simply isn't true. There are two main reasons for this. First, due to the simultaneous use of the channel by multiple stations, the improper performance of any one station's demodulator degrades the performance of the channel for ALL of the other stations. Therefore all stations have a responsibility to configure their radio properly for the mode. Note that this is fundamentally different from the case of operation on modes like RTTY or CW. On these modes, if a decision is made by any one station to accept the performance degradation that accompanies excessive radio bandwidth, that station is the only one which pays a penalty for the decision. On a busy packet channel, everyone is forced to pay.

Second, the performance gain due to reducing the radio bandwidth is substantially larger than the gain due to reducing only the demodulator audio bandwidth. Even a demodulator with filtering at audio will perform substantially better when the radio bandwidth is appropriately limited than when it is not. CW performance is not the issue here. If the owner of the radio is interested in getting adequate performance from packet radio operated at 300 baud (A)FSK with 200 Hz shift, he or she WILL have the 500 Hz filter installed in the radio I.F. strip. This will be true regardless of any filtering done at audio frequencies.

Your editorial comment also implies that HF packet operation is an appliance operator's mode. This is not true and it will not be the case for some time to come. I am disappointed to see that some manufacturers have such a low opinion of their customers' abilities. I do not believe that the skill required to configure the radio properly for the mode is beyond the capability of the average ham who is on HF packet. It CERTAINLY is not beyond the capability of ALL of them. Anyone who feels incapable of doing the job will no doubt do the thing hams have traditionally done in this situation, he will seek (and receive) help from another ham who IS capable in this area. But first he needs to have the knowledge that this is necessary.

That was one of the main reasons for writing the article in the first place. Many radios are in operation which do allow the operator to select the appropriate bandwidth independent of the setting of the mode switch. A few which spring to mind are the old Drake twins, the KWM-380 series, any of the modern transceivers which have provision for an accessory narrow ssb filter (these tests were run on a TS-430 with a 500Hz filter installed in the SSB narrow position), the TS-440 / 940...etc. Any of the radios with variable passband tuning such as the Yaesu FT-757 can be warped around to provide a significant degree of selectivity in the I.F. strip properly centered on the packet signal. In the limiting case, if the radio is to be dedicated to HF packet operations (as many are), the narrow filter can be installed in place of the wider SSB filter. Very little skill is required to do this to ANY SSB transceiver.

Radios which provide for direct FSK while in CW mode can also be used in this mode for packet thus allowing direct selection of the CW filter. In

fact, I have worked many stations on the air using exactly this scheme. It has worked very well even though some of them hadn't yet recalibrated their shift up to 200 Hz from 170 Hz.

Centering the demodulator in the receiver passband is a problem only for those demodulators which are difficult to align or make no provision for operation on frequencies other than a few line standards. At least one commercially available TNC has user-settable modem frequencies. None of the TAPR TNCs and clones based on the 2211 demodulator have this problem either. Realignment of the 2211 demodulator center frequency in these units requires only the adjustment of exactly 1 (one) 20 turn trimpot. Since this represents a large fraction of the operational TNCs, modem frequency adjustment would seem to present very little problem for most packeteers.

Nowhere in the article do I suggest that it is detrimental to include a filter at audio. To be sure, if the radio does not have the appropriate bandwidth I.F. filter installed, and the audio filter doesn't degrade the dynamic range of the demodulator, in the absence of adjacent channel interference, a filter at audio will slightly improve the demodulator performance. However, due to AGC capture considerations, operating in the real world, a filter at audio can never be as effective as one which is ahead of the AGC detector in the radio. Unfortunately this is especially true of the typical filter slicer type demodulator since it is much more sensitive to audio level variations than are the non filter based demodulators. When an unwanted signal is operating the receiver AGC system, the result is wide variation in audio level presented to the demodulator.

Now, to the issue of extra cost... We are talking about configuring a station to operate on a new mode which is significantly different from the modes in use when most of the radios currently being used were designed. A TNC is required. This is an extra cost option costing approximately \$100 to \$400. A terminal or computer is required. This is an extra cost option costing anywhere from \$25 at the flea market for a used VIC-20 to many thousands of dollars for a full up AT or clone. I don't really feel that the additional cost of a proper filter for the radio will hinder anyone who has already decided to spend money on the above items in order to get on the mode. In fact, there is a significant cost incurred by a manufacturer when he installs a complex, or difficult to align (or both) audio filter in the TNC. I can only assume that this cost is ultimately passed on to the consumer (Please let me know if THIS is not true!). Therefore, even an audio filter installed in the TNC by the manufacturer can be considered an extra cost option. The real issue then is since an extra cost filter is needed, which is the most effective choice on a cost/performance basis.

In my case, I already owned a TNC with a modem in it. This modem was not based on filters and did not include any significant filtering at audio frequencies. On HF, the performance could be improved either by filtering at audio or by filtering in the radio. If I was to obtain a commercially available solution I could either spend on the order of \$150 for an onboard modem based on filters or I could spend \$45 on a 500 Hz CW filter to put in the radio. Needless to say, I chose the

continued on page 19 >>>



## Plug-in FSK Modem for TNC-2

(C) COPYRIGHT 1986 by Gil Mays, VK6AGC  
ALL RIGHTS RESERVED

The plug-in FSK modem design presented herein is the copyrighted property of Gil Mays, VK6AGC. You are granted permission to use this design in a non-commercial environment, and to copy it and distribute it, provided that the following conditions are satisfied:

1. No fee may be charged for such copying and distribution.
2. This documentation including the PC board artwork may ONLY be distributed in its original, unmodified state.

Any voluntary contributions for the use of this modem design and documentation presented here will be appreciated from any users who find it of value.

Whether or not you make a contribution, you are encouraged to copy and distribute this documentation to other packeteers, provided that the above conditions are satisfied.

A copy of this documentation including the PC board artwork plots may be obtained for \$10 and should be sent to:

Gil Mays, VK6AGC  
74 Moolanda Blvd  
Kingsley, WA 6026  
Australia

For documentation orders outside Australia, please add an additional \$5, and enclose an international money order payable in Australian currency.

### GENERAL DESCRIPTION

This article presents a plug-in modem PC board designed for the TAPR TNC-2 and clones and implements the Advanced Micro Devices Am7910 "World Chip" modem IC [1]. The circuit diagram for this design is shown in Fig. 1. The PC board artwork plots are shown in Fig. 2.

The Am7910 is a complete asynchronous Frequency Shift Keying (FSK) modem in a 28-pin DIL package. No external filtering is required. Signal modulation, demodulation and filtering functions are performed by digital signal processing techniques. The device contains on-chip analog-to-digital (ADC) and digital-to-analog (DAC) converters.

An external clock signal is provided by the TNC-2 and is applied to the device. All the digital input and output signals (except the external clock signal) are TTL compatible. The power supply requirement is  $\pm 5$  volts which is supplied by the TNC-2. The device can operate at rates of 300, 600 or 1200 bits per second, and is compatible with the recommended standards for Bell 103, 202 and CCITT V.21, and V.23 type modems. Five mode control lines allow the selection of a desired modem configuration.

### MODES AND MODE CONTROL INPUTS

The mode control inputs on the Am7910 (pins 17-21) select the desired modem configuration. The appropriate modem can be selected by setting the voltage on the corresponding inputs to a TTL high or a low. A DIP switch is used for this application, and allows the user to change the modem setting as desired. The individual switches are designated as follows:

S1 - MC4,    S2 - MC3,    S3 - MC2,    S4 - MC1,    S5 - MC0

These five inputs select one of thirty-two modem configurations according to the Bell or CCITT specifications listed in table 1 below. However, only 19 of the 32 modes are actually available to the user.

Modes 0 to 8 are normal operation modes. The 1200 bps modes can be selected with or without a compromise equalizer (I recommend using it for Bell 202!).

### LOOPBACK MODES

Modes 16 to 25 are loopback modes. These modes are usually used for testing the modem which permits "loopback" of the Am7910 modulator and demodulator circuits, as described below. This is required when using a full-duplex mode, such as Bell 103 or CCITT V.21, in half-duplex packet operation, as used on HF. Whenever a loopback mode is selected, the transmit and receive filters are set to the same channel frequency band so that loopback can be performed.

Loopback allows the analog output, TRANSMITTED CARRIER, and the analog input, RECEIVED CARRIER, to be connected for local analog loopback testing. Alternatively, the digital input, TRANSMITTED DATA, and the digital output, RECEIVED DATA, can be connected externally, allowing a remote modem to test the local modem with its digital data signals looped back. Do NOT connect these signals as loop back testing of the modem is not necessary!

The loopback facility is used to permit operation on HF using the 300 bps full-duplex protocols in the half-duplex packet environment. If a full-duplex mode is selected without loopback (S1 - MC4 closed!) the modem will transmit on one frequency pair and receive on another pair (Table 2).

#### MODE SELECTION

NOTE: Modes 9 to 15 and 26 to 31 are reserved and should NOT be used.

For our packet radio requirements, only four modes are used: modes 2, 3, 16, and 21. Table 1 below shows the switch settings and binary codes for these modes. Modes 2 and 3 implement the Bell 202 protocol, 1200 bps FSK half-duplex used on 2 meter VHF networks. The only difference between mode 2 and mode 3 is in the demodulator filter response.

Mode 16 is the Bell 103 Originate (with loopback), full-duplex 300 bps 200 Hz shift for HF packet operation when communicating with Kantronics type TNCs. Mode 21 is the CCITT V.21 Answer (with loopback) protocol, full-duplex 300 bps 200 Hz shift for communicating with TAPR type TNCs. This is the mode that is used most for HF packeting.

MC4	MC3	MC2	MC1	MC0	
0	0	0	0	0	Bell 103 Originate 300 bps full duplex
0	0	0	0	1	Bell 103 Answer 300 bps full duplex
0	0	0	1	0	Bell 202 1200 bps half duplex
0	0	0	1	1	Bell 202 equalized 1200 bps half duplex
0	0	1	0	0	CCITT V.21 Originate 300 bps full duplex
0	0	1	0	1	CCITT V.21 Answer 300 bps full duplex
0	0	1	1	0	CCITT V.23 Mode 2 1200 bps half duplex
0	0	1	1	1	CCITT V.23 Mode 2 equalized 1200 bps half duplex
0	1	0	0	0	CCITT V.23 Mode 1 600 bps half duplex
0	1	0	0	1	-----
0	1	0	1	0	
0	1	0	1	1	
0	1	1	0	0	Reserved
0	1	1	0	1	
0	1	1	1	0	
0	1	1	1	1	-----
1	0	0	0	0	Bell 103 Originate loopback
1	0	0	0	1	Bell 103 Answer loopback
1	0	0	1	0	Bell 202 Main loopback
1	0	0	1	1	Bell 202 equalized
1	0	1	0	0	CCITT V.21 Orig loopback
1	0	1	0	1	CCITT V.21 Answer loopback
1	0	1	1	0	CCITT V.23 Mode 2 loopback
1	0	1	1	1	CCITT V.23 Mode 2 equalized loopback
1	1	0	0	0	CCITT V.23 Mode 1 loopback
1	1	0	0	1	CCITT V.23 Back loopback
1	1	0	1	0	-----
1	1	0	1	1	
1	1	1	0	0	
1	1	1	0	1	Reserved
1	1	1	1	0	
1	1	1	1	1	-----

Table 1 -- Mode Selection

Note: 1 indicates open switch, 0 a closed switch

#### MODEM CONFIGURATION

Bell 103 and CCITT V.21 are full-duplex protocols -- the modem receives on one pair of tones and transmits on another pair simultaneously. Since, when operating on HF, the modem needs to transmit and receive on the same frequency pair, the loopback modes are used for normal packet operation on HF.

Modem	Baud Rate Dup	Transmit Frequency		Receive Frequency	
		Space	Mark	Space	Mark
Bell 103 Orig	300 Full	1070	1270	2025	2225
Bell 103 Ans	300 Full	2025	2225	1070	1270
CCITT V.21 Orig	300 Full	1180	980	1850	1650
CCITT V.21 Ans	300 Full	1850	1650	1180	980
CCITT V.23 Mode 1	600 Half	1700	1300	1700	1300
CCITT V.23 Mode 2	1200 Half	2100	1300	2100	1300
CCITT V.23 Mode 2 Equalize	1200 Half	2100	1300	2100	1300
Bell 202	1200 Half	2200	1200	2200	1200
Bell 202 Equal.	1200 Half	2200	1200	2200	1200
CCITT V.23 Back	75 -	450	390	450	390
Bell 202 Back	5 -	*	*	**	**

\* (BRTS LOW) and (BTD HIGH): 387 Hz at TC (ERTS HIGH) or (BTD LOW): 0 volts at TC  
 \*\* 387 Hz at RC: BCD LOW No 387 Hz at RC: BCD HIGH  
 [This information is not applicable for packet operation]

Table 2 -- Modem Configuration

### THEORY OF OPERATION

The modulator receives binary digital data in NRZI format from the TNC, and converts the data to an analog signal using frequency shift keying (FSK) modulation. The tones produced by the modulator are digitally synthesized sine functions. The digital signal is sent through bandpass filters, and the FSK signal is converted to an analog signal by a digital-to-analog (DAC) converter. This analog FSK signal is then passed through an analog post filter.

The received signal is an FSK-modulated analog carrier. The first stage of the demodulator is an analog pre-filter. The output of this is converted into digital form by an analog-to-digital (ADC) converter, and filtered by digital bandpass filters to improve the signal-to-noise ratio. The bandpass filtered output is finally digitally demodulated to recover the binary NRZI data. A carrier-detect signal (DCD) is also digitally extracted from the received carrier to indicate valid data.

### CIRCUIT DESCRIPTION

When one of the mode control switches, S1-S5, is open, the corresponding mode control input is set to -5V (logic high) via one of the pull-up resistors, R1-R5. When one of the switches is closed, the corresponding pin is grounded (logic low). The large value (470K) for the pull-up resistors (R1-R5) reduces the current drain on the -5V supply. To select a modem configuration, the appropriate mode control inputs are set high by opening the corresponding switches (Table 1).

A low logic level on the Data Terminal Ready (DTR) input indicates the data terminal, or TNC in this case, is ready to send and/or receive data via the modem. This input is permanently pulled low via R6 to enable all other TTL inputs and outputs.

### DATA RECEPTION

When the receiver detects a valid carrier, which has been present for a specified period of time, a low appears on the Carrier Detect (CD) output. The Received Carrier (RC) input is the analog signal received at the RX Audio (J2 pin 4) pin of the TNC radio connector. The modem extracts the information contained in this modulated carrier and converts it into a serial data stream for presentation at the Received Data (RD) output. Data bits demodulated from the received carrier input are available serially at this output. HIGH (mark) indicates logic 1 and LOW (space) indicates logic 0.

The digital NRZI data is sent to the latch (U5) and state machine (U6) via the modem disconnect (J4 pin 17) which recovers the clocking information and converts the NRZI to NRZ format for presentation at the SIO (U21).

### DATA TRANSMISSION

Data transmission is initiated by asserting the Request To Send (RTS) input to the modem. When the TNC is ready to transmit, the SIO (U21 pin 17) asserts the RTS line which is presented at J4 pin 5. A logic low level on this line causes the modem to enter transmit mode. This input remains low for the duration of data transmission.

At the end of a delay initiated when the RTS goes low, the Clear To Send (CTS) output goes low. The TNC will not send data until the CTS line is asserted. This signal is an input to the SIO (U21 pin 18) via J4 pin 9, which activates the PTT line low via the watchdog timer.

Data bits to be transmitted are presented serially at the Transmitted Data (TD) input. The NRZI binary data present at J4 pin 19 is the data from the TNC which is available at this input. HIGH (mark) corresponds to a logic 1 and LOW (space) corresponds to a logic 0.

This data determines which frequency is presented at the Transmitted Carrier (TC) output pin according to modem selected (Table 2). The transmitted carrier output is the modulated carrier which is filtered and sent to the TX audio (J2 pin 1) pin on the radio connector. No signal appears at the transmitted carrier output unless RTS is low.

Data transmission continues until RTS is unasserted. Following a short delay, CTS goes high. As soon as RTS is high, the TD input is ignored and the TC output is set to 0.0 volts.

The Back Request To Send (BRTS) line is the only "back channel" control line which must be connected. This line must be set to 5 volts, unasserting BRTS for normal operation of the modem. For this reason, a 12K pullup resistor is used. An explanation of the back channel operation is not within the scope of this article, however, an understanding of this is provided in the data and application notes [1].

#### INTERFACING THE MODEM TO THE TNC-2

The PC board is designed to interface to the TNC-2 by plugging into a 20-way DIL male header on the modem disconnect, J4. Not all of the signals available at J4 are required by the modem. The only signals required at this connector are: TX Data (pin 19), RX Data (pin 17), GND (pin 15), -5V (pin 16), CTS (pin 9), PTT (pin 10), and RTS (pin 5). The other signals needed by the modem are provided at the 5-pin connector (P2) on the modem PC board. These signals are: Clock (pin 1), CD (pin 2), -5 volt (pin 3), RC (pin 4), TC (pin 5).

Do NOT cut all of the traces on the solder-side of the TNC board, between each pair of adjacent pins of J4. Only cut the traces between pins 5 and 6, pins 19 and 20. Pin 1 on the 20-way header corresponds to pin 1 on J4.

#### +5V AND -5V SUPPLY

The 5 volt and -5 volt power supply requirement of the modem is available on the TNC-2. The -5 volt regulator, U3 7805, is replaced with a 3 amp version, 78T05. A wire is soldered from the +5 volt output of the 78T05 to J4 pin 16 (this pin is normally unused on the TNC-2) which provides the -5 volt supply to the modem. The -5 volt supply available on the Tuning Indicator connector, J3 pin 1, is a suitable pick-off point. A wire is soldered from J3 pin 1 (for convenience) to the corresponding pin on the modem board, P2 pin 3.

#### CLOCK SIGNAL

The 2.4576 MHz external clock signal output from U10 pin 6 on the TNC provides the modem with the necessary clock frequency at the XTAL1/CLK input (pin 24). Solder a wire from JMP 2 (pin 2 or 3) to the clock pin on the modem connector, P2 pin 1.

#### CARRIER DETECT (CD)

To prevent the DCD LED from remaining ON, cut either the cathode or anode lead of CR15. Solder a wire from the cathode of CR13 to the CD pin on the modem connector, P2 pin 2 -- this provides the carrier detect signal from the modem. Since the carrier detect output from the modem is used to sense when a carrier is detected, the RF DCD line (J2 pin 5) should NOT be connected.

#### RECEIVED CARRIER (RC)

The receive carrier input to the modem is available at the RX AUDIO input on the radio connector, J2 pin 4. Solder a wire from C35 (the trace that connects to C57 and U17 pin 8) to the RC pin on the modem connector, P2 pin 4.

#### TRANSMITTED CARRIER (TC)

The transmit carrier output from the modem is the modulated analog signal which is sent to the TX AUDIO output on the radio connector, J2 pin 1. Cut one of the leads of R57 (560). Solder a wire from the anode lead of C33 to the TC pin on the modem connector, P2 pin 5.

### INITIAL CHECKOUT

Once you have installed all of the components on the PC board, except the Am7910, and performed the necessary modifications to the TNC-2 PC board as described above, plug the modem board into the TNC modem disconnect (J4) and connect the 5-way connector to P2. The two trimpots allow the signal levels of the transmitted carrier and received data to be adjusted. Preset both trimpots counterclockwise until you hear the element "click". Rotate the adjustment screw on RV1 (TC) about 5 turns clockwise. Measure the resistance from TC (P2 pin 2) to ground and set to about 1.2K. Rotate the adjustment screw on RV2 (RD) about 3 turns clockwise. Measure the resistance from RD (P1 pin 19) to ground and set to about 1K. These adjustments are only approximate, and should be set to suit your particular TNC and radio setup.

Power on the TNC and check to see that there is +5 volt on pin 2 of U1. Check that -5 volt is on pin 4 of U1. If these voltages do not checkout ok, turn the TNC off and check your construction. If all is ok, turn the TNC off and install the Am7910. Select the desired modem configuration by setting the switches on the DIP switch according to tables 1 and 2. Also ensure the radio baud rate on the TNC is properly selected. You are now ready for packet operation.

### CONCLUSION

The Am7910 FSK modem circuit presented in this article, was designed specifically for the TAPR TNC-2 and clones, and has been in use in several TNCs in the Perth LAN (PERTHNET) for a couple of months now.

Happy packeting!

[1] Data sheet and application notes are available from Advanced Micro Devices, 901 Thompson Pl., P.O. Box 453, Sunnyvale, CA 94086.

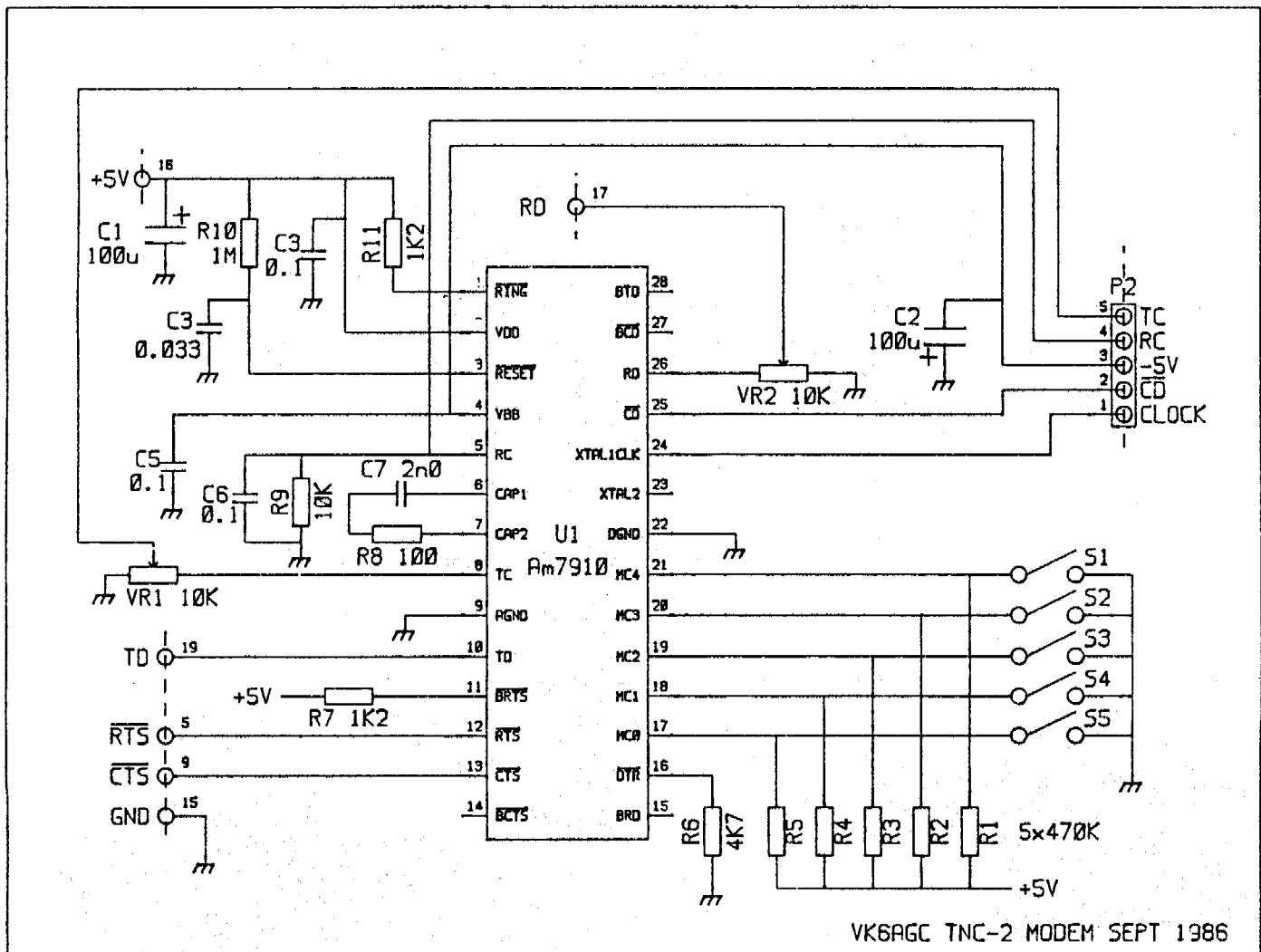

Fig. 1. Schematic diagram for TNC-2 modem.

The first part of the document discusses the importance of maintaining accurate records of all transactions. It emphasizes that proper record-keeping is essential for the integrity of the financial system and for the ability to detect and prevent fraud. The text also mentions the need for regular audits and the role of independent auditors in ensuring the reliability of financial statements.

The second part of the document focuses on the role of the accounting profession. It highlights the need for accountants to adhere to high standards of ethical conduct and to maintain their professional competence through continuous education. The text also discusses the importance of transparency and accountability in the accounting process.

The third part of the document addresses the challenges faced by businesses in the current economic environment. It discusses the impact of global economic uncertainty and the need for businesses to adapt to changing market conditions. The text also mentions the importance of innovation and the role of government in supporting business growth.

The fourth part of the document discusses the role of technology in the accounting industry. It highlights the benefits of automation and the use of data analytics in improving efficiency and accuracy. The text also mentions the need for accountants to stay up-to-date on the latest technological developments.

The fifth part of the document discusses the importance of corporate governance and the role of the board of directors. It emphasizes the need for transparency and accountability in the management of the company and the importance of the board in overseeing the company's operations.

The sixth part of the document discusses the role of the financial markets and the importance of investor protection. It highlights the need for transparency and disclosure in the financial markets and the importance of the regulatory framework in ensuring the integrity of the markets.

The seventh part of the document discusses the role of the financial system in supporting economic growth and development. It highlights the importance of a stable and efficient financial system and the need for the government to ensure the integrity of the system.

The eighth part of the document discusses the role of the financial system in supporting the real economy. It highlights the importance of the financial system in providing capital to businesses and the need for the government to ensure the integrity of the system.

The ninth part of the document discusses the role of the financial system in supporting the environment. It highlights the importance of the financial system in providing capital to businesses that are focused on sustainable development and the need for the government to ensure the integrity of the system.

The tenth part of the document discusses the role of the financial system in supporting the social sector. It highlights the importance of the financial system in providing capital to businesses that are focused on social development and the need for the government to ensure the integrity of the system.

The eleventh part of the document discusses the role of the financial system in supporting the cultural sector. It highlights the importance of the financial system in providing capital to businesses that are focused on cultural development and the need for the government to ensure the integrity of the system.

The twelfth part of the document discusses the role of the financial system in supporting the sports sector. It highlights the importance of the financial system in providing capital to businesses that are focused on sports development and the need for the government to ensure the integrity of the system.

The thirteenth part of the document discusses the role of the financial system in supporting the arts sector. It highlights the importance of the financial system in providing capital to businesses that are focused on arts development and the need for the government to ensure the integrity of the system.

The fourteenth part of the document discusses the role of the financial system in supporting the media sector. It highlights the importance of the financial system in providing capital to businesses that are focused on media development and the need for the government to ensure the integrity of the system.

The fifteenth part of the document discusses the role of the financial system in supporting the entertainment sector. It highlights the importance of the financial system in providing capital to businesses that are focused on entertainment development and the need for the government to ensure the integrity of the system.