



# PACKET

# STATUS

# REGISTER



## Tucson Amateur Packet Radio Corporation A Non-Profit Research and Development Corporation

Winter 1995  
Issue # 57

**Published by:**  
Tucson Amateur Packet Radio  
8987-309 E. Tanque Verde Rd.#337  
Tucson, AZ 85749-9399  
Phone: 817-383-0000  
FAX: 817-566-2544

**Office Hours:**  
Tuesday - Friday  
9:00am-12:00, 3:00-5:00pm Central  
14:00-17:00, 20:00-22:00 UTC

In This Issue...	
1995 ARRL DCC .....	3
Update on the Hierarchical Addressing Protocol .....	3
Position Paper on Packet Bulletins.....	4
EASTNET VHF/UHF Backbone System...5	
Amateur HF Digital Bibliography.....	6
Special Interest Group News .....	8
MFJ-9600 Modem Modification.....	10
Interfacing the DevMeter to a PRO-508..	10
Network for Volcano Monitoring.....	11
Regional Club List.....	14
@USBBS: Feedback .....	15
IC-970 Modem Interfaces for Satellite Communications .....	16
IC-970 Modification For 9600 bps Operation.....	17
User and Development Interfaces for the DSP-93.....	18
D93WE .....	18
DSP-93 Control .....	23
Packet Radio on the World-Wide-Web! ..	25
DRSI Ends Sales of Ham Products .....	25
TAPR TNC-2 Release 1.1.9.....	27
FCC Denies Reconsideration of Message Forwarding Rules.....	28
Spread Spectrum STA Renewed.....	28
NPRM: Spectrum Below 5 GHz Transferred from Federal Use .....	29
TAPR Organization News.....	32

### President's Corner

#### Reflections

1994 was a good year in many ways for TAPR. The Board set eight goals for 1994, which were: 1) continue to watch spending closely, 2) continue to work on increasing membership, 3) work on getting Special Interest Groups active, 4) get closure on current projects, 5) finish work on kit revamps in progress, 6) develop more TAPR involvement in national perspectives, 7) develop more TAPR publications, and 8) finalize TAPR's short and long term goals. The first seven goals were achieved with some success. I'll touch on each in a second. The eighth is an ongoing task and we will continue this activity in the future.

The financial statement for November has us in the black and it looks like it will stay that way through December. This will make a second year of positive operations. The Special Interest Groups that were started in March '94 have grown from two groups to six by the end of the same year. On the kit front, the DSP-93 reached closure and began making both TAPR and AMSAT money, the TUC-52 project is nearing prototyping, and the PSK kit, TNC-2 bare board, and DevMeter kit were discontinued. TAPR started to get more involved in national issues and will continue to work more on this area as opportunities appear for our input. In the area of

**Look for TAPR at these Upcoming Events**  
March 3-5, 1995 TAPR Annual Meeting (St. Louis)  
April 28-30, 1995 Dayton Hamvention  
Sept. 8-10, 1995 ARRL Digital Communications Conference

**Packet Status Register**  
Tucson Amateur Packet Radio Corp.  
PO Box 51114  
Denton, TX 76206-0114

**SECOND CLASS  
POSTAGE PAID AT  
DENTON, TX.**

ADDRESS CORRECTION REQUESTED

Member #: 201 Expiration: 1/1/96  
Phil R. Karn (KA9Q)  
7431 Teasdale Ave. #P  
San Diego, CA 92122-2830

publications, TAPR arranged an agreement with the ARRL concerning past proceedings of the digital conferences and TAPR began to develop a series of books to be published in 1995. The increase in membership was the happiest goal to achieve. The goal that was set by the board was to increase membership beyond 2,000 by the end of 1994. The goal was reached in October and we continue to get new members in daily. Thanks to all those that help with membership and welcome to all the new members! Membership makes this organization operate and allows everyone to benefit from the TAPR effort.

I would like to pay my compliments to outgoing board members Jack Davis, WA4EJR, and Ron Bates, AG7H. Although they will be leaving the board, I do not expect them to become any less active in TAPR. Jack continues to help with parts procurement and TrakBox issues, while Ron has been working with the TUC-52 project group. Thanks for all their effort this last year!

### The Upcoming Year

TAPR still has a lot more to continue to work on in 1995. The annual meeting looks like it will be a great event and I look forward to seeing everyone in St. Louis in March. The TAPR election sees four excellent candidates running this year and whoever is elected should bring excellent energy to the board for the next three years. Last year we saw over 50% response from the membership. I hope we can get that good a response this year in voting. As for membership, I would like to see TAPR set a new membership goal of 5,000 members by 1997. This would be another doubling of the membership, which I believe can be accomplished. The set of goals I will be proposing to the TAPR board in March will include: 1) continue to be ever watchful on expenses, 2) continue to work on increasing membership, 3) continue to develop TAPR involvement in national perspectives, 4) continue to look at ways of providing more operational capabilities for digital operators, and 5) work on making TAPR a more rounded national organization. One of the keys to TAPR's success in the long-term future is building good working relationships with the various regional and digital interest groups. This will allow both TAPR and the regional groups involved to become stronger by working together on educational and research issues.

On the "don't forget" list, we have the annual meeting in March followed by TAPR's packet activity at Dayton. Dayton is going to see a few changes this year (read further in the *PSR*). Don't forget to send in your ballot for the election when you get it. Your vote counts. Don't forget, we still need help in answering

Entire contents Copyright © 1995 Tucson Amateur Packet Radio Corp. Unless otherwise indicated, explicit permission is granted to reproduce any materials appearing herein for non-commercial Amateur publications provided that credit is given to both the author and TAPR, along with the TAPR phone number (817-383-0000). Other reproduction is prohibited without written permission from TAPR.

Opinions expressed are those of the authors and not necessarily those of TAPR, the Board of Directors, Officers, or the Editor. Acceptance of advertising does not constitute endorsement, by TAPR, of the products advertised.

**Postmaster:** Send address changes to TAPR, P.O. Box 51114, Denton, TX. 76206-0114. *Packet Status Register* (ISSN 1052-3626, USPS 005-419) is published quarterly by the Tucson Amateur Packet Radio Corporation, 1418 Ridgecrest, Denton, TX 76205. Membership in Tucson Amateur Packet Radio, including a subscription to *Packet Status Register*, is \$15.00 per year in the U.S. and possessions, of which \$12.00 is allocated to *Packet Status Register*. Membership is \$18.00 in Canada and Mexico, and \$25.00 elsewhere, payable in U.S. funds. Membership and *Packet Status Register* cannot be separated. Second-class postage paid at Denton, TX.

#### PSR Editor:

Bob Hansen, N2GDE  
P.O. Box 1902, Elmira, N.Y. 14902-1902  
Internet: psr@tapr.org  
CompuServe: 71121,1007



#### Advertising: Maingate Resources.

Phone: 817-295-6222. FAX: 817-295-6232

#### TAPR Officers:

President	Greg Jones, WD5IVD
Vice President	Keith Justice, KF7TP
Secretary	Gary Hauge, N4CHV
Treasurer	Jim Neely, WA5LHS



#### TAPR Board of Directors:

<u>Board Member</u>	<u>Term</u>	<u>Internet</u>
Ron Bates, AG7H	1995	ag7h@tapr.org
Jack Davis, WA4EJR	1995	wa4ejr@tapr.org
Bob Hansen, N2GDE	1996	n2gde@tapr.org
Gary Hauge, N4CHV	1996	n4chv@tapr.org
Greg Jones, WD5IVD	1997	wd5ivd@tapr.org
Keith Justice, KF7TP	1996	kf7tp@tapr.org
John Koster, W9DDD	1997	w9ddd@tapr.org
Jim Neely, WA5LHS	1995	wa5lhs@tapr.org
Mel Whitten, K0PFX	1997	k0plx@tapr.org

Date is expiration of term on Board of Directors.

The Tucson Amateur Packet Radio Corporation is a non-profit scientific research and development corporation [Section 501(c)(3) of the U.S. tax code]. Contributions are deductible to the extent allowed by U.S. tax laws. TAPR is chartered in the State of Arizona for the purpose of designing and developing new systems for digital radio communication in the Amateur Radio Service, and for disseminating information required during, and obtained from, such research.

#### Article submission deadlines for upcoming issues:

Spring 1995	March 15, 1995
Summer 1995	June 15, 1995
Fall 1995	September 15, 1995
Winter 1996	December 15, 1995

#### Submission Guidelines:

TAPR is always interested in receiving information and articles for publication. If you have an idea for an article you would like to see, or you, or someone you know, is doing something that would interest digital communicators, please contact the editor so that your work can be shared with the Amateur community.

The preferred format for articles is plain ASCII text; the preferred graphic formats are HPGL or PCX. However, we can accept many popular word processor and graphic formats. All submissions on diskette should be formatted for MS-DOS.

questions, so if you think you can help, contact Dorothy at the office. Don't forget, when contacting one of our advertisers to mention where you saw their ad. It helps us and them to know that their ads in the *PSR* are doing them good. Azden joins us this quarter as a new advertiser.

I would like to welcome Keith Sproul, WU2Z, and the APRS-SIG he will chair as the latest SIG to be formed in TAPR. This should be an excellent resource for those interested in APRS activities. Read the SIG section for more information on what this is all about. On a last note I would like to congratulate Bob Hansen, N2GDE, for another excellent year of *PSR* editing and production. Much has happened in Bob's life and many do not recognize the commitment Bob has made in the last eight months to continue to produce the *PSR*. In addition, the *PSR* continues to change its look and we all feel that it only gets better. Thanks, Bob.

Until next issue, cheers - Greg Jones, WD5IVD

---

## 1995 ARRL Digital Communications Conference

Dave Wolf, WO5H  
Vice-President, Texas Packet Radio Society

Mark your calendar and start making plans to attend the year's premier event in Amateur radio digital communications. The 14th Annual ARRL Digital Communications Conference will be held September 8-10, 1995, in Arlington, Texas — just minutes from Dallas/Ft. Worth Airport. Co-hosts for the conference are TAPR and the Texas Packet Radio Society.

More detailed information on the event, including a call for papers, conference and hotel registration, will be released soon. Contact the TAPR office to be added to the mailing list for DCC '95 information.

This notice is to alert you well in advance so that you may schedule work and family obligations, and think about potential paper topics.

The hotel/conference center are extremely well-suited and well-sited for this event. They regularly host other ham events, and staff members are very familiar with the sight of satellite dishes springing up on the lawn! They, and we, are looking forward to a tremendous conference. I hope YOU can be a part of it!

---

## Update on the Proposed Hierarchical Addressing Protocol

As a result of very constructive feedback from the TAPR on-line SIGs, the proposal has been revised so that the local and regional identifiers are included in supplemental tables, rather than in the body of the proposal itself. This way, the master document may stay intact with little or no revision over a long period of time. The regional (Table 3) and area (Table 4) identifiers may be updated quite frequently without the need to consult the original authors. This also places the responsibility for local addresses within the hands of the folks creating those particular address elements. It makes this a 'living' document that encourages frequent revision by its very nature, rather than a static one that discourages revision.

It is the purpose of this document to establish a basic framework upon which to base a logical hierarchical addressing structure. Attached Supplemental Tables will be changed as necessary to reflect current configurations within the international BBS network.

The original proposal was published in *PSR* #56. The comment period continues until January 31, 1995. Send comments and Supplemental Table input to:

Dave Wolf, WO5H, TAPR BBS-SIG Chair  
Packet: wo5h@wo5h.#dfw.tx.usa.noam  
Internet: dwolf@tcet.unt.edu  
Fax: (817) 295-6232

### Hierarchical Addressing Compliance

It is unreasonable on the part of any sysop to exclude traffic from another station because he won't adopt a particular addressing scheme. Part of the process which led to the development of the proposed hierarchical addressing recommendations was intense discussion on BBS-SIG. This discussion included comments from many that mis-routing of Amateur packet mail via the internet would not occur (even if the address could be confused somehow as an Internet address) **as long as the gateway sysop set up his/her files correctly.**

The fellow who insists that another sysop change his hierarchical address is overzealous and unreasonable. He would more likely win a convert to NOAM if he used more tactful methods. Luckily, most folks exhibit more flexibility as far as hierarchical addressing is concerned. Continue to deal with them, and the more rigid will do what metal does — if it refuses to bend, it eventually fatigues at one spot.

Hopefully, this won't grow to a nation-wide flamfest and hopefully, not become a long thread on BBS-SIG.

## Position Paper on Packet Bulletins

### Tucson Amateur Packet Radio

Approved and released by the Board of Directors,  
October 28, 1994

There has been a recent flurry of activity on the packet networks, as documented on BBS-SIG, over some packet bulletins issued by Frederick Sober, AB6GQ, an Official Observer Coordinator in the Sacramento Valley section of the ARRL. The concern expressed by AB6GQ is that packet bulletins whose contents do not relate to Amateur radio are in violation of Part 97. I have reviewed AB6GQ's bulletin, two letters from (FCC Personal Radio Branch Chief) Johnny Johnston, and discussed the matter personally with AB6GQ by phone on Sunday, October 23rd.

Here is a brief history of events, primarily reported by Frederick: in 1993 as an OO, AB6GQ was contacted by several local packet BBS sysops who were concerned over the content of bulletins addressed, for example, to ALL @ ALLUS, ALL @ WW, and so forth. The content of many of these bulletins did not include ham radio-related subject material, and they wondered if this was a violation of Part 97. According to Frederick, he contacted his section manager, who advised him to get in touch with League headquarters. He was advised by a League Regulatory Information staffer to contact the FCC directly. Someone at the Hayward field office referred him to Washington. An exchange of correspondence with Johnny Johnston ensued (texts of Mr. Johnston's letters have been transcribed to the SIG from copies obtained by Greg Jones). AB6GQ has been advised that the League is going to 'undertake an educational effort' about which something will appear in QST after the first of the year. Frederick advises he is going to wait for further word through the League chain of command for his next, if any, action regarding packet bulletins.

Because the spark which created this particular packet 'crisis of the day' was a statement to other Amateurs from an Official Observer Coordinator, and because there was a reported exchange of correspondence with an FCC branch chief, Greg Jones, President of TAPR, received numerous phone calls asking for TAPR's position on this matter. Greg discussed this situation with several League officials and other respected advisers prior to discussing it with the TAPR Board of Directors. Subsequently, Greg requested that I draft this position statement for TAPR.

To be succinct, most of the flame wars and great debates over permissible communications exhibit a problem with semantics, not a lack of specificity in the

rules. Packet is not some mutant communications form that is not definable by the rules. Packet is no more or less privileged than any other form of Amateur communications. (Packet is used here, but this argument extends to all legal forms of Amateur digital communications which are used for the forwarding of bulletins)

Did you know that Part 97 comes complete with its own dictionary? 97.3 includes a list of definitions for the terms used in the document. Two definitions that are either overlooked or misinterpreted by many are 'broadcasting' and 'informational bulletin.' 'Broadcasting' specifically means transmissions intended for reception by the general public (see 97.3 (10)). The term 'informational bulletin,' defined by Part 97.3 (23) has no relation to what we refer to as a packet 'bulletin.' Part 97 defines an 'informational bulletin' as a one-way transmission to hams of a message of subject matter composed solely of interest to the Amateur service. A good example of an informational bulletin is a transmission of ARRL bulletins from W1AW. To conclude that all of this means that a packet bulletin must be confined to Amateur-only subject material is using terribly convoluted logic. Except for unproto, there is no one-way packet mode. It takes two to tango. A packet bulletin is entered on a BBS from the originating station in a two-way communication. From then on out, that packet bulletin is a third-party message. If it gets forwarded from one BBS to another, it is a third-party message being forwarded during a two-way communication.

97.113 lists prohibited communications and their exceptions. There is no specific prohibition against content with potentially controversial or frivolous subject material. This particular 'crisis of the day' arose, as so many others have arisen, because of message content. There is general agreement that many of the bulletins traversing the network aren't worth the electricity used to forward them. Studies in several metropolitan areas show that over 70% of the bulletins NEVER get read. They just get listed. This means users are being very selective about what they read. They DO have a choice. So do sysops. The process of reducing the amount of what many of us consider to be 'noise' on our boards begins with each of us exercising leadership at home. If someone posts a SALE @ ALLUS bulletin on your board trying to unload a camping tent, tell them nicely that this isn't appropriate. If you have a religious fanatic or political alarmist climbing on the electronic soapbox (and that soapbox has your call sign stenciled on the side), it's time for a heart-to-heart. Easy? Not always. Whoever said that running a BBS was gonna be easy? What are you doing to get the word out that packet radio, while

sometimes loose, is not a free-for-all. Ham radio, ALL facets of ham radio, because of the wide constituency we have, is a place where people have to be responsible. It's much harder to educate than legislate, but which do you think has the more effective results?

The lessons learned: If you've got a question about the rules, use the resources available to you WITHIN the Amateur community INSTEAD of making an end run straight to the Commission. Document who you speak with and what was said. Get whatever you can in writing. Think of the potential impact on ALL of Amateur radio when a small chunk of the overall activity (such as packet in relation to everything else) is the focus of possible new regulation or enforcement. This is not to suggest that the rules be violated or that anyone stick their head in the sand about abuses that may exist. It is better to try to take care of business ourselves, as we are encouraged to do in the rules, than to invite possible over-regulation by the FCC. This issue may be put to rest forever preferably by the League setting the record straight that packet bulletins are not one-way transmissions or broadcasting, and that 97.113 is explicit about permissible content of Amateur communications.

Incidentally, I found AB6GQ to be very open about this incident and very surprised to find himself at the eye of a hurricane. He admits to a degree of initial naiveté in his effort to be a responsible OO (and now an OOC). Frederick wants everyone to know that he and his team of OOs don't have a hidden agenda and most importantly, they aren't vigilantes. They wanted some answers to questions about packet bulletins. Some missteps and miscommunications (by numerous people) led to something being given far more relevance than it deserved.

Submitted October 24, 1994  
Dave Wolf, W05H  
TAPR BBS-SIG Chair

---

## **EASTNET VHF/UHF Backbone System**

John T. Gubernard, K2LSX  
jtg@intac.com

The EASTNET VHF/UHF Backbone System [a.k.a. the "EastNet BackBone Network"], referred to as the "EBN," was designed to allow packet information from users and BBSs to flow smoothly over part of the eastern region commonly called "EASTNET." This is being accomplished by building a structured system, with controls on growth to create an environment of maximum throughput. The EBN is not a club or organization, rather a group of interested packeteers who wish to create a packet radio network

without engaging in political activities associated with many large clubs.

The EBN is structured into three sub-networks, the Local Area Network (LAN), the Regional Network, and Area Network. They are designed as follows:

### **Local Area Network**

The Local Area Network (LAN) is a point of entry into the EBN system. User stations can connect to other users, other nodes, PBBSSs, TCP/IP servers, or gateways on these LAN nodes. All LAN nodes are multi-port nodes removing all inter-node traffic from the LAN or user frequency. The LANs are the only access point available to users of the EBN system.

### **Regional Network**

The Regional Networks are limited access networks designed to allow communication between nodes within a geographic region. Access to the Regional Network is limited to multi-port network nodes, PBBSSs (for mail forwarding only), TCP/IP Gateways, Contest Clusters, and other public server stations. Information destined to nodes outside the Regional Network is sent to the Area Network node associated with that Regional Network.

### **Area Network**

The Area Network is a main long haul backbone of the EBN. The purpose of this backbone is to move traffic between distant areas of the network, typically about 100 miles between nodes, using above average sites. Area network nodes also serve a Regional Network linking that Regional Network to an Area Network. Communication between the Regional and Area Network is through the RS-232 port of the TNCs at the Area Network site.

The structure of the Area and Regional Networks was designed to be transparent to users allowing future upgrades to be implemented without any user impact.

The following is a list of active individuals and their e-mail addresses who are associated with the EBN in the Northern New Jersey and Southern New Jersey areas.

Mark Herson, N2MH mherson@intac.com  
Joe Mannino, W2NV joe@intac.com  
Barry Siegfried, K2MF bgs@intac.com  
Al Shjarback, WB0MPQ als@intac.com  
John Gubernard, K2LSX jtg@intac.com  
Charlie Benn, WB2SNN wb2snn@wb2cop.nj.usa.na  
Bob Anderson, K2BJG k2bjg@wa2sna.nj.usa.na  
Ron Hoffman, K2KFE k2kfe@nx2b.ampr.org

# Amateur HF Digital Bibliography

Rick Whiting, W0TN

Someone on the Ham Digital newsgroup was looking for info on PACTOR the other day. This prompted me to go through my files and prepare a bibliography. This was limited, for the most part, to the ham periodical literature. I specifically excluded professional journals and books as these can be easily located through normal library research techniques. Did I miss any "good ones"?

## Amateur Radio Periodical Literature Bibliography

### HF Digital Communications W0TN, Rev. 0, 10-07-94

#### ALE (Automatic Link Establishment)

- Adair, Robert T., KA0CKS, David Peach, and Dennis Bodson, W4PWF, "The Growing Family of Federal Standards for HF Radio Automatic Link Establishment (ALE)," Part 1, The National Communications System, The Federal Standards Development Process, and the Basic Definition of Federal Standards 1045 through 1054, *QEX*, July 1993, pp. 3-8.
- Wortendyke, David, N0WGC, Chris Riddle, KB0HNM, and Dennis Bodson, W4PWF, "The Growing Family of Federal Standards for HF Radio Automatic Link Establishment (ALE)," Part 2, Compact Disc for Testing HF ALE Radios, *QEX*, Aug. 1993, pp. 9-14;
- Brewster, Larry, N0RNX, and Dennis Bodson, W4PWF, "The Growing Family of Federal Standards for HF Radio Automatic Link Establishment (ALE)," Part 3, Where are the Federal Standards for HF ALE Radio Networking Going?, *QEX*, Sept. 1993, pp. 14-19;
- Sutherland, David, and Dennis Bodson, W4PWF, "The Growing Family of Federal Standards for HF Radio Automatic Link Establishment (ALE)," Part 4, Network Simulation for the Radio Amateur, *QEX*, Oct. 1993, pp. 13-18.
- Smith, Paul C., K3ZMO, and Dennis Bodson, W4PWF, "The Growing Family of Federal Standards for HF Radio Automatic Link Establishment (ALE)," Part 5, An Amateur's Practical Approach to HF ALE Radio Systems, *QEX*, Nov. 1993, pp. 9-12.
- Redding, Christopher, and Dennis Bodson, W4PWF, "The Growing Family of Federal Standards for HF Radio Automatic Link Establishment (ALE)," Part 6, Federal Standard 1049—The Future of ALE Operation in Stressed Environments, *QEX*, Dec. 1993, pp. 7-9.
- Levreault, Bob, W1IMM, and Ken Wickwire, KB1JY, "Some Recent Amateur Use of Federal Standard Automatic Link Establishment (ALE) Signaling," *Proceedings of the 11th ARRL Conference on Digital Communications*, Nov. 1992, pp. 32-39.

#### AMTOR/SITOR

- Bingemer, Armin, DK5FH, "AMC—The AMTOR Controller," *QEX*, Feb. 1992, pp. 3-11.
- Henry, Bill, K9GWT, "New AMTOR Mode," *CQ*, Nov. 1989, pp. 36-40.

- Huslig, Michael J., "Unique Identification Signals For CCIR 625," *Proceedings of the 12th ARRL Conference on Digital Communications*, Sept. 1993, pp. 28-29.
- Martinez, Peter, G3PLX, "AMTOR, An Improved Error-Free RTTY System," *QST*, June 1991, pp. 25-27.
- Newland, Paul, AD7I, "An Introduction to AMTOR," *QST*, July 1983, pp. 11-13.
- Newland, Paul, AD7I, "Algorithms and Methods For SITOR/AMTOR Systems," *QEX*, July 1988, pp. 9-12.
- Young, Teresa, Stephen Rieman, and David Wortendyke, N0WGC, "A Preview of HF Packet Radio Modem Protocol Performance," *Proceedings of the 13th ARRL Conference on Digital Communications*, Aug. 1994, pp. 152-155.
- "HF Modem Over-The-Air Performance Test Report, Globe Link Corporation HF Modem Model GLC-1000A," Fed. Emergency Mgmt. Agency (FEMA), Washington, DC, 20472, Feb. 22, 1993.
- "HF Modem Over-The-Air Performance Test Report, Ascom Radiocom Ltd. ARTOR HF Modem," Fed. Emergency Mgmt. Agency (FEMA), Washington, DC, 20472, April 12, 1993.

#### APLINK (AMTOR to AX.25 Packet Link)

- Mortensen, Jim, N2HOS, "APLINK: The Delivery System—Part 1," *QST*, Oct. 1991, p. 73.
- Mortensen, Jim, N2HOS, "APLINK: The Delivery System—Part 2," *QST*, Nov. 1991, pp. 81-82.

#### CLOVER

- Horzepa, Stan, WA1LOU, "CLOVER: The Future of HF Data Communications?," *QST*, Jan. 1993, p. 107.
- Petit, Raymond C., W7GHM, "The 'Cloverleaf' Performance-Oriented HF Data Communication System," *QEX*, July 1990, pp. 9-14.
- Petit, Raymond C., W7GHM, "The CLOVER-II Communications Protocol Technical Overview," *Proceedings of the 11th ARRL Conference on Digital Communications*, Nov. 1992, pp. 47-51.
- Petit, Raymond C., W7GHM, "CLOVER-II: A Technical Overview," *Proceedings of the 10th ARRL Conference on Digital Communications*, Sept. 1991, pp. 125-129.
- Westhuizen, Mike Van Der, ZS6UP, "A Practical Comparison Between Clover and Pactor Data Transfer Rates," *CQ*, Vol. 50, No. 2, Feb. 1994, pp. 40, 42.
- Young, Teresa, Stephen Rieman, and David Wortendyke, N0WGC, "A Preview of HF Packet Radio Modem Protocol Performance," *Proceedings of the 13th ARRL Conference on Digital Communications*, Aug. 1994, pp. 152-155.
- "HF Modem Over-The-Air Performance Test Report, HAL Communications Corp. PCI-4000 HF Modem," Fed. Emergency Mgmt. Agency (FEMA), Washington, DC, 20472, July 6, 1993.

#### G-TOR

- Anderson, Phil, W0XI, Michael Huslig, Glenn Prescott, WB0SKX, and Karl Metcalf, WK5M, "G-TOR The New, Faster HF Digital Mode for the KAM-Plus," Kantronics, Inc., 1202 E. 23rd St., Lawrence, KS 66046, U.S.A., 1994.
- Huslig, Mike, Phil Anderson, Karl Metcalf, and Glenn Prescott, "G-TOR: The Protocol," *Proceedings of the 13th ARRL Conference on Digital Communications*, Aug. 1994, pp. 49-79.

Huslig, Richard, and Phil Anderson, "GMON—A G-TOR Monitoring Program for PC Compatibles," *Proceedings of the 13th ARRL Conference on Digital Communications*, Aug. 1994, pp. 80-85.

Prescott, Glen E., WB0SKX, and Phil Anderson, W0XI, "A Theoretical Evaluation of the G-TOR Hybrid ARQ Protocol," *Proceedings of the 13th ARRL Conference on Digital Communications*, Aug. 1994, pp. 86-89.

Prescott, Glenn, WB0SKX, Phil Anderson, W0XI, Mike Huslig, and Karl Medcalf, WK5M, "G-TOR: A Hybrid ARQ Protocol for Narrow Bandwidth HF Data Communication," *QEX*, May 1994, pp. 12-19.

Prescott, Glenn E., WB0SKX, and Phil Anderson, W0XI, "Hybrid ARQ For HF Data Transmission," *Communications Quarterly*, Vol. 4, No. 3 (Summer), 1994, pp. 31-40.

### **Packet (AX.25) [Not recommended for HF]**

*AX.25 Amateur Packet-Radio Link-Layer Protocol, Version 2.0*, Oct. 1984, American Radio Relay League, 225 Main St., Newington, CT 06111, U.S.A.

Karn, Phil, KA9Q, "Spectral Efficiency Considerations for Packet Radio," *Proceedings of the 10th ARRL Conference on Digital Communications*, Sept. 1991, pp. 62-66.

McLarnon, Barry D., VE3JP, "HF Packet: Where Do We Go From Here?," *Proceedings of the 6th ARRL Conference on Digital Communications*, Aug. 1987, pp. 126-133.

Young, Teresa, Stephen Rieman, and David Wortendyke, N0WGC, "A Preview of HF Packet Radio Modem Protocol Performance," *Proceedings of the 13th ARRL Conference on Digital Communications*, Aug. 1994, pp. 152-155.

### **PACTOR**

Clas, Martin, DL1ZAM, and Peter Mack, DL3FCJ, "PTC—The PACTOR Controller," *QEX*, Oct. 1991, pp. 7-11.

Helfret, Hans-Peter, DL6MAA, and Ulrich Strate, KF4KV, "PACTOR—Radioteletype With Memory ARQ and Data Compression," *QEX*, Oct. 1991, pp. 3-6.

Reedy, Gwyn, W1BEL, "PACTOR: An Overview of a New and Effective HF Data Communication Protocol," *Proceedings of the 11th ARRL Conference on Digital Communications*, Nov. 1992, pp. 62-64.

Westhuizen, Mike Van Der, ZS6UP, "A Practical Comparison Between Clover and Pactor Data Transfer Rates," *CQ*, Vol. 50, No. 2, Feb. 1994, pp. 40, 42.

Young, Teresa, Stephen Rieman, and David Wortendyke, N0WGC, "A Preview of HF Packet Radio Modem Protocol Performance," *Proceedings of the 13th ARRL Conference on Digital Communications*, Aug. 1994, pp. 152-155.

"HF Modem Over-The-Air Performance Test Report, Globe Link Corporation HF Modem Model GLC-1000A" Fed. Emergency Mgmt. Agency (FEMA), Washington, DC, 20472.

### **PACTOR II**

Rink, Dr. Tom, DL2FAK, "Update on the Development of PACTOR-2," Special Communications Systems, Rontgenstr. 36, 63454 Hanau, Germany.

### **Miscellaneous**

Baiya, Harun, David Balson, and Gary Garriott, "Digital Radio Technology and Applications," *Proceedings of Intl.*

*Workshop organized by the Intl. Dev. Res. Center, Volunteers In Technical Assistance (VITA), and UN University, Nairobi, Kenya, Aug., 1992.*

Cadmus, Clayton, KA0GKC, and Bruce L. Meyer, W0HZR, "FSK Signal Monitor," *Communications Quarterly*, Vol. 3, No. 2 (Spring), 1993, pp. 45-50.

Chandler, Dr. Alan, K6RFK, "HF Modems for Data Transmission, A look at the Differences Between Commonly Used Designs," *Communications Quarterly*, Vol. 1, No. 2 (Spring) 1991, pp. 74-78.

Clark, Tom, W3IWI, "Comments on HF Digital Communications Part 1—Link Level Issues," *Proceedings of the 9th ARRL Conference on Digital Communications*, Sept. 1990, pp. 265-270.

Clark, Tom, W3IWI, "Comments on HF Digital Communications Part 2—Data Protocol Issues," *Proceedings of the 9th ARRL Conference on Digital Communications*, Sept. 1990, pp. 271-274.

Henry, Bill, K9GWT, and Ray Petit, "HF Radio Data Communication, CW to CLOVER," *Communications Quarterly*, Vol. 2, No. 2 (Spring), 1992, pp. 11-24.

Johnson, Lyle V., WA7GXD, "Thoughts on an Adaptive Link Level Protocol," *Proceedings of the 8th ARRL Conference on Digital Communications*, Oct. 1989, pp. 97-107.

Kinsner, W., VE4WK, "Lossless Data Compression Algorithms for Packet Radio," *Proceedings of the 10th ARRL Conference on Digital Communications*, Sept. 1991, pp. 67-75.

Karn, Phil, KA9Q, "Toward New Link-Layer Protocols," *QEX*, June 1994, pp. 3-10.

McIntyre, Lewis F., "Error Correction In Data Transmission," *Communications Quarterly*, Nov. 1990, pp. 88-94.

Nagle, John J., K4KJ, "Diversity Reception: An Answer to High Frequency Signal Fading," *Ham Radio*, Nov. 1979, pp. 48-55.

Shapiro, Garry, NI6T, "Optimizing the PK-232MBX for RTTY and AMTOR," *Communications Quarterly*, Vol. 3, No. 1 (Winter), 1993, pp. 83-91.

Sykes, B., G2HCG, "The Enhancement of HF Signals By Polarization Control," *Communications Quarterly*, Nov. 1990 pp. 23-28.

Wickwire, Ken, KB1JY, "The Status and Future of High Frequency Digital Communications," Part 1: Overview, *QEX*, June 1992, pp.3-14.

Wickwire, Ken, KB1JY, "The Status and Future of High Frequency Digital Communications," Part 2: HF Modems and Their Performance, *QEX*, July 1992, pp. 3-15.

Wickwire, Ken, KB1JY, "The Status and Future of High Frequency Digital Communications," Part 3: Simulating The Performance Of HF Digital Networks, *QEX* August 1992, pp. 12-17.

Wickwire, Ken, KB1JY, "The Status and Future of High Frequency Digital Communications," Part 4: Where Is HF Digital Networking and Where Is It Going, *QEX*, Oct. 1992, pp. 10-18.

"Low-Cost Digital and Packet Radio Techniques: Operation and Applications," Volunteers in Technical Assistance (VITA), Arlington, VA, Spring 1994.

*Proceedings of the 3rd FEMA MF/HF Packet Radio Conference*, Fed. Emergency Management Agency (FEMA), Washington, D.C. 20472, April 1992.

## Introduction of the APRS Special Interest Group

Keith Sproul, WU2Z

Automatic Packet Reporting System (APRS) is a system used for tracking people, weather, objects, weather balloons, and many other aspects of Amateur Radio. APRS was developed by Bob Bruninga, WB4APR, and was first introduced to the Amateur Radio community at the ARRL Computer Networking Conference in 1992 in New Jersey. Over the last couple of years, APRS usage has grown and extended all across the country, and many new features have been added to this system.

The goal of this Special Interest Group is to create a forum for people interested in this type of activity so that they can ask questions, compare notes, and exchange ideas. We will discuss things pertaining to APRS itself, GPS, GPS unit applications of this type of technology, automatic weather reporting, uses of APRS in public events such as bike-a-thons, and uses of APRS in emergencies.

I can be reached as follows:  
Keith Sproul, WU2Z  
698 Magnolia Road  
North Brunswick, NJ 08902-2647  
Work: 908 563-5389,  
Fax: 908 563-5035  
akasbb1@peabody.sct.ucarb.com  
Packet: wu2z@kb4cyc.nj.usa

To subscribe to this mailing list send a message to 'listserv@tapr.org' with the following line in the body of the message:

subscribe aprssig FirstName LastName

## BBS-SIG Report

Dave Wolf, W0SH  
BBS-SIG Chair  
Internet: dwolf@tcet.unt.edu  
CompuServe: 73427,2246

The TAPR BBS-SIG has seen some reasonable activity over the past quarter. The largest issues discussed on the SIG included: permissible bulletin topics on packet, education vs. legislation, reducing overhead of packet messages, refining the TAPR hierarchical proposal for final presentation to the Board of Directors.

The issue which generated the hottest responses was, by far, permissible bulletin content. For details on the entire story behind the story, please see the TAPR position paper in this issue of the *PSR*. The position paper was picked up by the W5YI Report (December 15, 1994) and used as their back page item. It was to have appeared in the January 1995 *QST*, but it is our understanding it was cut at the last minute. Pity. The folks who could benefit most from this are the users.

An update to the proposal for an X.3.4 hierarchical address standard (published in the last issue) also appears elsewhere in this issue of *PSR*. There will be those who will dig in their heels and fight the change from NA to NOAM and cite many reasons for not doing so. The reasons for X.3.4 go beyond connectivity to the Internet or any other alternative communications network. Hams need a continental element that has greater precision than two place holders offers (that won't conflict with any state/provincial elements!).

Barry Buelow, WA0RJT, is working on a BBS User's Guide. This should go a long way to

increasing the sophistication of our user base. I know, there are some sysops who like to have unsophisticated users because that makes the sysop feel that much smarter. In reality, the smarter your users are, the more fun you'll have running your BBS! Your reasons for adopting a certain policy or changing the way your board is configured are easier to explain if your user base is better educated. One very simple thing I do personally, is to print out the user docs (that come bundled with AA4RE software) with a few revisions and formatting and spelling corrections to make it look pretty. I send these docs to anyone sending an SASE, and extend this offer in my help and introduction files. This is appreciated by the users and makes it more of a peer-to-peer project, rather than a 'I am the BBS guru, you are the idiot' situation that exists in many communities. I'm looking forward to seeing his work, and from working with him on TAPR projects, know it will be top notch. What are YOU doing to promote better understanding of our digital modes on the local, regional and national levels? There's unlimited opportunity if you have interest!

We are looking forward to three big events for the in-person BBS-SIG: the TAPR Annual Meeting in St. Louis, the Dayton HamVention, and the Digital Communications Conference in Arlington, Texas. To make these more meaningful events for all participants, your input is hereby solicited for topics you would like covered. Some volunteer help would certainly be appreciated too. Keeping track of the SIG participants, tracking responses to any surveys that are made during the events, and such. Let me hear from you if you are planning on attending any of these events and



wish to help with the organizational aspect of the SIG meetings.

There's something I could use some help with and I hope someone jumps forward to volunteer. The on-line BBS-SIG has, like most on-line discussion groups, a perpetual ambient 'noise level' with some occasional gems making themselves apparent above the background din. The BBS-SIG could use, for lack of a better term, a SCRIBE, who would capture the best of the best from the BBS-SIG and TAPR would make it available for all interested. This would be a great assignment for someone who is interested in the work of the SIG, yet might not be interested in entering the issues arena on their own. Internet access is required for you to download and upload SIG activity. Let me know if you would make a good candidate!

Looking forward to seeing you in St. Louis if you can make it, and on-line if you can't.

## Scribes Needed

Scribes are needed for writing an overview of a selected SIG each quarter for the *PSR*. Contact [tapr@tapr.org](mailto:tapr@tapr.org) if you are interested and your message will get forwarded to the correct SIG chair. This is an important job that needs to be done.

## HF-SIG Report

Johan Forrer, KC7WW  
HF-SIG Chairman

This is a summary report that covers the period middle October through December 15, 1994. The archived messages are available for retrieval from the TAPR list server.

## 1. General.

The activities of the group started October with introductions by various interested parties. Common interests include: HF BBS/Gateway operations, Emergency (Red Cross), relief (FEMA) and volunteer (VITA) groups, and Technical interests. Although there presently is a somewhat technical slant to the discussions, any topics related to HF are welcome and are encouraged.

## 2. Modulation-demodulation Methods for HF Digital.

A good start was made with an introductory listing of reference materials on topics such as ALE, CLOVER, G-TOR, AX-25, PACTOR (II), and other miscellaneous HF-communications issues.

While in "open house" mode, several useful modulation schemes were suggested, such as the family of modems built around MIL-STD-188-141A (ALE), MIL-STD-188-110 (16 or 39 parallel tones), chirp, and multi-tone orthogonal signaling. The latter submission by Phil Karn, sounded quite interesting and is worthy of further investigation. Another possibility is "Piccolo," i.e., multi-frequency signaling (MFSK).

Evidently, several promising options are possible for future exploration; however, it is a little early to make any guess which will be chosen. Probably, the classic arguments of how to arrive at the best bandwidth efficiency need to be evaluated and revisited. With the DSP and PC processing power available to Amateur experimenters, a lot can be achieved. This topic is likely to receive further attention in the future.

## 3. DSP platforms.

There is no question that the interest in DSP techniques for future Amateur HF digital projects will continue. The costs of such DSP platforms have now also become affordable and within reach of Amateurs. There are exciting projects ahead and hopefully will give you the opportunity to expand your knowledge of both theory and applications. Although the learning curve is quite steep, the rewards are great.

The TAPR DSP-93 and DSP-sound card options (described in the August and November 1994 *QEX*), were discussed as possible platforms — each having advantages and considerations — use what you feel comfortable with. Hopefully, it would be possible to document our algorithms in pseudo code that could be ported to your favorite processor. It may also be worth following developments on the DSP and DSP-93 SIGs — once they get started.

## 4. HF Ionospheric Channel Simulator.

There is a need for methods and tools to evaluate experimental modems. The development of such a tool for radio Amateurs was put forward as a possible first objective of this group. It was felt that if such a project were within the capabilities of our present equipment, this would be a great achievement as it would be invaluable during experimental work.

This device, also known as a "channel simulator," operates at base band, i.e., audio frequencies, and is supposed to be connected in the audio path between two modems under test. The simulator models the complex effects that the

ionosphere has on the propagation of radio signals. A number of typical conditions are possible, i.e., "GOOD", "MODERATE", "POOR", and "FLUTTER FADING". In addition "FLAT FADING" conditions are also defined. These conditions are the result of multipath propagation. Random noise will also be included in addition to multipath effects.

Once this need for a simulator was realized, valuable contributions were made by the group in locating technical papers and providing assistance with various formulae and algorithms. This kind of combined effort has proven to be very worthwhile

One of the key documents that described such channel simulators

was provided in the CCIR recommendations:

CCIR Report 549-2, "HF Ionospheric channel simulators",

CCIR Recommendation 520-1, "Use of high frequency ionospheric simulators".

It was shown how to obtain these CCIR documents: Access the ITU/TIES information via gopher:

- use your own gopher client and access to info.itu.ch on port 70, or
- telnet to gopher.itu.ch on port 2000

Please send any messages to "helpdesk@itu.ch"

These CCIR documents, however, are based to a large extent on the work done by Watterson et. al and described in:

Clack C. Watterson, John R. Juroshek, and William D. Bensema: "Experimental Confirmation of an HF

Channel Model". *IEEE Trans. on Comm. Tech.* Vol COM-18(6) December 1970.

An example from the literature of hardware and software to implement such a model was suggested in:

L.Ehrman, L.B. Bates, J.F. Eschile, and J.M. Kates. "Realtime Software Simulation of the HF Radio Channel" *IEEE Transactions on Communications*, August 1982, p.1809.

A first attempt at simulating the workings of the model, is being evaluated at this time.

Your participation and contributions are most valuable — please consider joining us in this adventure.

## MFJ-9600 Modem Modification

David Bray, N0ITS  
 N0ITS @ KB0CZV.#NWCO.CO  
 dcbr@chevron.com

I have been working with other node-ops around my area to assist them with setting up 9600 baud links, and have found a disturbing characteristic of **all five** of the MFJ-9600 modems I have come in contact with.

If the transmit output level on the modem is set to anything over the lower 1/3 or 1/2 of the adjustment range the signal becomes very distorted. I have determined that the source of this trouble is when the signal passes through Q4 and Q5 on the modem board. I have been bypassing these transistors by removing C34 and C37, connecting them in series, and re-inserting them back into the board so that the signal will still go from U10 (pin 1) to the output of the modem. The only reason I can see that Q4 and Q5 are there in the first place is to remove the TXD line from PLL radios when the oscillator you are modulating is also a reference for the receiver.

When this change is made, the modem gives a clean output signal, and is working well in our network at all five locations where these modems are in place. I have successfully interfaced this modem with Motorola Micor UHF mobile, Motorola Maxar UHF mobile, and Motorola Syntor UHF mobile radios. I hope this helps all of you out there.

## Interfacing the TAPR Deviation Meter to a PRO-508

Toshio Imao, JA2DXY

Thank you for developing the very convenient TAPR Deviation Meter Kit (version 1.0). This report describes how to interface this tool to a Radio Shack PRO-508 Scanner.

Step 1: connections:

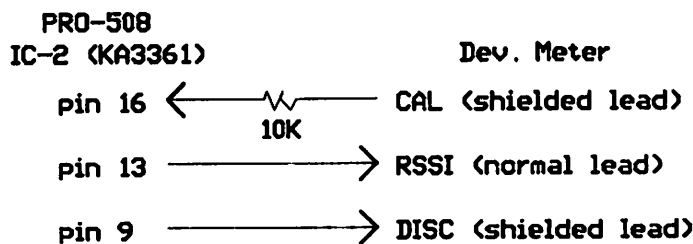

Step 2: Configuration of the EEPROM values:

**B65A change to 29 ; for IF frequency**  
**B65B change to CC ; change to 10.7 MHz**

**B62B change to 85 ; for discriminator**  
**B62C change to 00 ; output polarity**  
**B62E change to 85 ;**  
**B62F change to 1F ;**

This completes the modification except for the connection of the power supply lines.

# Packet Radio Network for Volcano Monitoring

Roland Machenbaum  
8 Tour-de-Champel  
1206 Geneve, Switzerland.  
internet: machen@univ-savoie.fr

## Abstract

This paper describes an implementation of a packet radio network on Taal volcano (Philippines). The network, based on Amateur radio hardware and software, allows the Philippine Institute of Volcanology and Seismology (PHIVOLCS) to retrieve real-time data from various instruments located on and around the volcanic island. The actual list of instruments includes 10 digital seismic stations, 3 tiltmeters, 2 radon sensors, 1 geochemical station (water temperature and conductivity), and an acoustic station. The original features of the network are the use of only one radio frequency simplifying frequency allocation procedures and equipment management, redundancy allowing failures of nodes without loss of data, and low power consumption reducing the cost of field power supplies.

The network is linked to the Internet by a radio link from PHIVOLCS to the University of the Philippines (UP). This link allows foreign organizations to access the data, and provides basic Internet services (mail, ftp, telnet,...) to PHIVOLCS and any user located in the Taal vicinity.

## The Volcano

Taal volcano is a 5 km diameter island located 60 km south of Manila and is situated in a 20 km diameter caldera filled by a lake. Its last eruption occurred in 1977 and its history is composed of several deadly eruptions. As such, it has been chosen as one of the 10 decade volcanoes by the International Decade for Natural Disaster Reduction commission (IDNDR).

Joint projects between PHIVOLCS and the University of Savoie, France have improved the monitoring of this volcano. Transfer of data between the island and PHIVOLCS' main office in Manila has always been a problem due to the lack of existing communication infrastructure on the island.

## Packet Radio Solution

Radio Amateurs have developed packet radio for more than 10 years now and have constructed a worldwide network supported by a constellation of satellites. The choice of Amateur radio hardware and software was motivated by its low price, proven reliability, and a large choice of equipment.

The basic equipment to access or create a network is a radio, a TNC (Terminal Node Controller) and a computer or terminal. The TNC chosen has a 9600 bps raw bit rate on the radio port and the radio is a 2 Watt UHF transceiver. The frequency assigned by the NTC (National Telecommunication Commission) for the network is 424.850 MHz.

A growing community is using the excellent NOS (Network Operating System) of Phil Karn, KA9Q which implements TCP/IP over packet radio. An upgraded version of NOS was used to link PHIVOLCS and the Taal network to the internet.

## TNC+

As suggested by its name, the TNC can act as a node and as a terminal simultaneously. The TNC alone acts as a repeater ("digipeater" in Amateur radio terms). With a computer connected to its serial port, more sophisticated routing functions can be added. Software exists to replace the original repeater function by higher-level routing functions, but most of the time the terminal function of the TNC is then lost. The digipeating scheme is not efficient in noisy environments if the number of hops between the source and destination is greater than 1. A packet lost on any segment of the link will be retransmitted starting from the source even if it successfully crossed the first segments. Delays and low throughput appear on a digipeater based network.

Most instruments cannot be connected directly to the serial port of the TNC. For the volcano monitoring application, it is costly and not practical to install a computer at every node of the network. So another kind of interface is needed.

Most of the nodes of the network will be idle when no measurements are being taken. For example, the sampling of a tiltmeter takes 10 seconds every 15 minutes. Power could be saved by turning off the unused communication equipment during idle time. Less power consumption results in less expensive, lighter and easier design of solar panel and battery power supplies.

To overcome the above problems it was decided to design a special interface board that would connect to the serial port of the TNC and add the following functions:

- packets are acknowledged on every segment to avoid retransmission over the whole link. This is an improvement over the digipeater scheme.
- switching off and on, at preset times, of the radio and TNC to save power.

- provide 3 asynchronous serial ports, 1 synchronous serial port, 16 output lines, 8 input lines, 1 counter input, 3 analog input channels (8 bit A/D converter)
- direct connection of up to 8 A/D converters (21 bit, 2 channels. analog amplifier with programmable gain ranging from 1 to 128)
- monitoring of the power supply voltage (battery level)
- remote modification of the TNC parameters
- a watchdog will reset the board and TNC if the TNC stays continuously on or off for more than 3 hours. This could be due to hanging of the board, the instrument, or the master PC. This feature improves reliability of the network.

The interface board is a MC68HC11 microcontroller with 32 Kb memory expandable to 128 Kb. The TNC is running a radio Amateur software package, called "The Firmware," copyrighted by NORD<>LINK. This software is labelled "free for non-commercial usage." The interface board uses the host mode of The Firmware. The TNC connected to its interface board was named TNC+.

### The Taalnet software

This software is running on a PC (386/33) and implements the master function of the network. It is written in Borland Pascal version 7 and runs in protected mode. It is composed of several units, one unit contains the specific list of commands used to retrieve data from each instrument. This unit needs to be updated when a new instrument is added. Field stations are called periodically. The current settings are the following:

The main 15-minute period is subdivided into three 5-minutes intervals.

At the beginning of the first interval, the low frequency data are retrieved, connections are established to the 3 tiltmeters, the 2 radon sensors and the geochemical station. The total call lasts 1.5 minutes so several low frequency instruments can still be added.

The second interval is reserved for the call to the acoustic station. This station is composed of a hydrophone located in the main crater lake at a depth of 40 meters and connected to a digital oscilloscope (Fluke Scopemeter PM97) through a set of filters. Taalnet will switch the filters and drive the oscilloscope to perform waveform acquisition at various frequencies. The call lasts from 1.5 to 3 minutes depending on the amount of data to be retrieved.

The last interval is dedicated for the call to the digital seismic stations. These stations continuously monitor seismic signals and a triggering algorithm runs concurrently to detect seismic events. Upon detection, the event is stored in the on-board memory. A maximum of 32Kb can be retrieved from this station due to limitations in the node's buffer. An external clock source consisting of an OMEGA signal receiver is needed to insure correct time stamping of the data. Only one station is called at each seismic station interval, so for 10 stations the period is 10x15 minutes (2 hours and 30 minutes). The call lasts from 2 to 5 minutes depending on the number of relays to be crossed. This scheme causes delays in the reception of seismic data but avoids the overloading of the network in case of seismic swarms. Previously, the 10 stations were polled for data at each seismic interval. This scheme will be reintroduced when another type of digital seismic station becomes available.

At the beginning of a call, an "unproto" (connectionless) packet is sent to synchronize the clock of remote nodes to the PC clock. The unproto mode was chosen to avoid automatic retransmission of these packets without control of the upper protocol layer. A node will read the contents of the synchronization packet and update its clock accordingly. If the packet was delayed due to retransmissions, the node would not be aware of that fact and would update its clock according to a time already elapsed. It is better not to receive a synchronization packet than to receive an incorrect one and have it retransmitted after an unknown delay.

At the end of each call, Taalnet checks the battery level of the nodes, the correct reception of the synchronization packet, the next wake-up time of the node, and if it has been reset. This information is stored in log files. If the node has reset, or if an error is detected, the wake-up configuration parameters will be sent. After no error is detected the node will be turned off. On the Taal network, 2 relays are configured as permanently "on" to allow communication over the network at any time (see Internet Access).

In case of failure of a link, another route, if available, will be tried. The new route will be remembered and tried first on the next call. Taalnet uses the Dijkstra algorithm to find the shortest route to a node.

The topology and the status of the network is displayed on the screen along with the time remaining before the calls to each node. Different colors show links currently used, links out of order, stations connected, and stations having low battery voltage. When no data transfer is in progress the user can use

the Taalgraf option (written by Nicolas Poussielle) which draws graphs showing the variation of all the parameters measured during the last 8 days. Taalgraf can also be invoked from any computer connected to the LAN (Local Area Network). Early battery problem detection is possible by using Taalgraf daily.

All Taalnet parameters and even Taalnet itself are stored on the file server (see Data Organization). This allows telemaintenance of the network through the Internet. People having access rights can remotely change the parameters or update the Taalnet version.

### Data Organization

A SUN IPX workstation is used as the central file server for Taal data by running the NFS server. If the LAN is operational, the data gathered by the Taalnet software is stored on the file server, if the LAN or the IPX is down, the data is stored on the local hard disk of the PC running Taalnet. Data will be appended automatically on the file server when the LAN is restored. Most of the PCs connected to the LAN are running the NFS client software allowing the access of Taal data by multiple users simultaneously. Foreign organizations can also access the IPX through the Internet allowing worldwide distribution of the data.

### Internet Access

The installation of the link to the Internet was done in collaboration with ASTI (Advanced Science and Technology Institute) based in the University of the Philippines (UP). Most of the work was done by Denis Villoriente of ASTI and comprised mainly of searching, compiling and testing of different NOS versions followed by correct configuration of the NOS parameters and other UNIX machines on the network. The hardware is composed of a PC with an ethernet board, a 9600 baud TNC, a TEKK radio and a Yagi antenna at each side of the link. The distance between PHIVOLCS and UP is about 5 km. ASTI is connected to the Internet via a 64 kbit/s leased line. The radio frequency used is the same as the one used for the Taal network. This allows any user in the Taal vicinity to access the Internet, and theoretically, any Internet user to access the Taal network, although problems will appear with heavy traffic. The parameters give priority to the gathering of data from Taal, but in case of poor radio conditions (encountered during daytime), the use of the same frequency will cause disconnections on the Taal network and the data currently being transferred will be lost. To overcome this problem the link to UP will be replaced by a public switched telephone link. However the radio interface in PHIVOLCS will be kept to allow users in the Taal vicinity to access the Internet.

The PCs are running the grinos (Gerard van der Grinten, PA0GRI) version of NOS. The PC in PHIVOLCS is also the mail server and users can read and write their mail from any computer running the popmail software and connected with an ethernet board to the LAN.

The domain "phivolcs.dost.gov.ph" was created with its primary name server consisting of a SUN SPARC 2 workstation located in the PHIVOLCS building. This phivolcs domain is not mandatory for the Internet connection, but to simplify separation between ASTI and PHIVOLCS.

Access to the Internet from Taal is done using a 9600 baud TNC, TEKK radio and a computer or terminal. An AX.25 connection is established to one of the PCs running grinos. The list of relays used (digipeaters) must be specified with the "connect" command. The user can then read or send his mail or issue a telnet connection to any Internet host. To check the latest data retrieved from Taal, the user needs to issue a telnet connection to the SPARC IPX of PHIVOLCS. If the user doesn't have his own TNC and radio he can go to any of the instruments and use the equipment there. Data gathering from Taal is not affected if the communication traffic is kept low. The access from Taal has proven its usefulness by facilitating the maintenance of the monitoring network: a technician or scientist in the field can keep in touch with his team anywhere in the world in case of questions or problems. In case of emergency, the network could help to relay information directly to and from the volcano and its surroundings.

### Source and cost of software and hardware mentioned in this paper:

nos, grinos: by ftp anonymous to ftp.ucsd.edu, free  
popmail: by ftp anonymous to univax.univ-savoie.fr, free  
nfs: by ftp anonymous to univax.univ-savoie.fr, 20 US\$/year (shareware)  
TNC+ composed of:  
TNC-2H (9600 baud): Symek, Germany, 250 US\$  
TNC interface board: contact the author, 350 US\$  
Radio KS-960: Tekk, USA, 250 US\$  
Taalnet: contact the author, free



## Regional Organization List

If you have corrections or additions to this list, please contact the office. TAPR hopes to keep this list as accurate as possible in order to refer information and individuals to their regional group(s). List is current as of 15 Dec. 1994

- Amateur Radio Research and Development Corp (AMRAD) PO Box 6148 McLean, VA 22106-6148 Newsletter: *AMRAD Newsletter*
- American Radio Relay League (ARRL) 225 Main St Newington, CT 6111 Internet: INFO@ARRL.ORG Newsletter: *QEX / Gateway*
- Arizona Packet Radio Association 8402 E Angus Dr Scottsdale, AZ 85251
- Central Illinois Packet Radio User Society (CIPRUS) c/o Larry Keeran K9ORP RR 1 Box 99B Downs, IL 61736-9717
- Central Iowa Technical Society (CITS) c/o Ralph Wallio WORPK 1250 Hwy G24 Indianapolis, IA 50125
- Chicago Amateur Packet Radio Association (CAPRA) PO Box 8251 Rolling Meadows, IL 60008 Newsletter: *The CAPRA Beacon*
- Cincinnati Amateur Packet Radio Experimenters Society (CAPRES) c/o John Schroer IV KA8GRH 948 Halesworth Dr Forest Park, OH 45240
- Colorado Digital Electronics (CODE) 3631 Brentwood Terrace Colorado Springs, CO 80910 Internet: info@code.org
- Colorado Packet Association (COPA) c/o John Radomski KTOH 2080 S Fairplay Aurora, CO 80014
- Connecticut Digital Radio Association (CONNECT) c/o Tom Hogerty, KC1J 83 Harold Rd Farmington, CT 6032
- Eastern Packet Radio of Michigan (EPROM) c/o Jay Nugent WB8TKL 3081 Braeburn Cir Ann Arbor, MI 48104
- EastNet BackBone Network (EBN) c/o John Gubernard, K2LSX 81 Harcourt Ave Bergenfield, NJ 07621-1916
- Florida Amateur Digital Communications Association (FADCA) 812 Childers Loop Brandon, FL 33511 Newsletter: *FADCA Beacon*
- Georgia Radio Amateur Packet Enthusiast Society (GRAPES) PO Box 871 Alpharetta, GA 30239-0871 Newsletter: *Grapevine*
- Hamilton and Area Packet Network (HAPN) Box 4466 Station D Hamilton, ON L8V 4S7 Canada  
HEX 9 Group PO Box 151 Oriila, ON L3V 6J3 Canada
- Mid-Atlantic Packet Radio Club c/o Tom Clark W3IWI 6388 Guilford Rd Clarksville, MD 21029
- Mississippi Amateur Radio Digital Association (MARDA) c/o Patrick J Fagan WA5DYV 2412 E Birch Dr Gulfport, MS 39503
- Mt Ascutney Amateur Packet Radio Association c/o Carl Breuning N1CB 54 Myrtle St Newport, NH 03773
- Mt Beacon Amateur Radio Club PO Box 841 Wappingers Falls, NY 12590
- New England Packet Radio Association (NEPRA) PO Box 208 East Kingston, NH 03827 Newsletter: *NEPRA PacketEar*
- North East Digital Association (NEDA) PO Box 563 Manchester, NH 03105
- Northern California Packet Association (NCPA) 6608B Alhambra Ave Suite 111 Martinez, CA 94553 Newsletter: *NCPA Download*
- Northwest Amateur Packet Radio Association (NAPRA) c/o John Gates N7BTI 750 Northstream Ln Edmonds, WA 98020 Newsletter: *Zero Retries*
- Ohio Packet Enthusiasts Club (OPAC) c/o Bob Ball WB8WGA 830 Riva Ridge Blvd Gahanna, OH 43230
- Oregon Digital Network Coordination Council (ODNCC) 7860 SW 69th Av Portland, OR 97223
- Pacific Packet Radio Society (PPRS) PO Box 51562 Palo Alto, CA 94303
- Packet Radio Organization of Montana (PROM) c/o Glenda Allen KE7TB 165 Conifer Rd Libby, MT 59923
- Packeteers of Long Island (POLI) c/o Alex Mendelsohn AI2Q 92 Hathaway Av Elmont, NY 11003 Newsletter: *The POLI Parrot*
- Pennsylvania Packet Association (PaPA) c/o Bryan Simanic WA3UFN 9 Wild Cherry Dr DuBois, PA 15801
- Radio Amateur Satellite Corp (AMSAT) PO Box 27 Washington, DC 20044 Newsletter: *AMSAT Journal*
- Radio Amateur Telecommunications Society (RATS) c/o J Gordon Beattie Jr N2DSY 206 North Vivyen St Bergenfield, NJ 07621
- Rochester Packet Group c/o Fred Cupp W2DUC 27 Crescent Rd Fairport, NY 14450
- San Diego Packet Group (SDPG) c/o Mike Brock WB6HHV 10230 Mayer Cir San Diego, CA 92126
- San Diego Packet Radio Association (SANDPAC) c/o Barry Gershenfeld 5085 Arroyo Lindo Av San Diego, CA 92117 Newsletter: *San Diego Packet Radio Association Newsletter*
- South Carolina Amateur Radio Digital Society (SCARDS) PO Box 1281 Columbia, SC 29202 Newsletter: *SCARDS Newsletter*
- Southern Amateur Packet Society (SAPS) c/o Wayne Harrell WD4LYV Rt 1 Box 368 Sycamore, GA 31790
- Southern California Digital Communications Council (SCDCC) PO Box 2744 Huntington Beach, CA 92647-2744 Newsletter: *The I-Frame*
- Tennessee Network (TENNET) c/o Jeffrey Austen K9JA 2051 Clearview Drive Cookeville, TN 38506 Internet: jra1854@tntech.edu
- Texas Packet Radio Society (TPRS) PO Box 50238 Denton, TX 76206-0238 Internet: dwolf@tcet.unt.edu Newsletter: *The TPRS Quarterly Report*
- Tucson Amateur Packet Radio Corporation (TAPR) 8987-309 E. Tanque Verde Rd #337 Tucson, AZ 85749-9399 Internet: TAPR@TAPR.ORG Newsletter: *Packet Status Register*
- TwinsLAN Amateur Radio Club c/o Kermit Kramer WORFD 1121 Xerxes Av S Minneapolis, MN 55405 Newsletter: *The TwinsLAN Beacon*
- Utah Packet Radio Association (UPRA) c/o Bart Van Allen KA7ZFD 11883 S Kinney Cir Riverton, UT 84065
- Vancouver Amateur Digital Communications Group (VADCG) 9531 Odlin Rd Richmond, BC V6X 1E1 Canada Newsletter: *The Packet*
- Wake Digital Communications Group (WDCG) c/o Randy Ray WA5SZL 9401 Taurus Ct Raleigh, NC 27612
- Western Michigan Packet Radio Association (WMPRA) PO Box 4612 Muskegon, MI 49444
- Wisconsin Amateur Packet Radio Association (WAPRA) PO Box 1215 Fond Du Lac, WI 54935 Newsletter: *Badger State Smoke Signals*

## @USBBS: Feedback

First of all, the article by Mr. Battles in the fall 1994 issue #56 of the *Packet Status Register* was well thought out. All in all, an excellent article.

My thoughts have been running into the same areas on how to keep the "SALE" and other bulletins down at a state/regional level as Mr. Battles has posed.

I particularly like the idea of everyone using TCP/IP, thereby eliminating the PBBS as we know it today. But, not knowing exactly how the Internet works from the commercial side, how would one send out bulletins that don't fit a certain criteria, so everyone can/could read it as the current PBBS system does? I'm not sure mailing lists would work. This may be an aspect you could write on in the future. Also, adding the last part of the article "The Alternative" again so that it ties it all in would go a long way in explaining what Mr. Battles really thinks should/could be done.

I'm going to ask my local BBS sysop what he thinks could be done. I'd hate to totally eliminate those kind of bulletins, but Mr. Battles was correct in stating, "A ham in Boston isn't likely to care about a personal computer for sale in Seattle."

Bill Neal, N0NSA/G7O AQ  
wmn3@aol.com  
n0nsa@sat.n51yt.ampr.org  
N0NSA@W5IFP.#782.TX.USA.NOAM

I have forwarded your message to Brian, the author of the article and Dave Wolf, TAPR BBS-SIG Chair. I think Dave will probably have some suggestions.

My suggestion and the one that most folks use is that the local BBS sysop should not allow these types of messages to enter the network. The first originating BBS should monitor all new messages and make sure that they are addressed correctly.

If they are not, in their opinion, then a message should be sent back to the originator stating why they thought so and with comments on how they should fix the routing in question.

Thanks for your comments.

Cheers - Greg Jones, WD5IVD

These comments are in reference to the article in the Fall 1994 Issue #56 of the *Packet Status Register* "The Alternative" on page 19.

Being a TCP/IP user and network builder, I fully support the use of TCP/IP by users. I think by more users using TCP/IP, maybe we can get rid of some of these AX.25 BBSs. It would be a miracle if all packet users would get on TCP/IP, but if we could only cut down on all the BBSs, that would be helpful.

With most every user using TCP/IP, and on a subnet with a mail server that will handle his mail, there would be no need for the user to be on 24 hours a day which is a problem for most users. The POP protocol of NOS could be used to retrieve his mail. Then, with users having an IP address which includes a valid operating subnet octet, other users will know exactly where to direct their packets to.

Of course with users all running TCP/IP, there will have to be knowledgeable people (known as Routing Managers) to maintain the necessary routing files which is a real necessity to make all this work. All these routing managers must work together so as to maintain a world-wide IP routing list. Now this is some job.

In talking to individuals about getting on TCP/IP in my area, their comments are: "it's too complicated to understand." I think if there were more articles on TCP/IP explaining how to put together a TCP/IP station, there would be more users getting on. What is needed is HOW TO articles on TCP/IP, starting from what equipment is needed, where to get the software and, if possible, a list of volunteers in all local areas to act as ELMERS for the new users. Finding an ELMER is probably the most important item.

Well those are my comments, again, I fully support the use of TCP/IP.

John T. Gubernard, K2LSX  
jtg@intac.com

### **PSR Deadlines**

Check page two for upcoming PSR deadlines. *The deadline for issue #58, Spring, is March 15th, 1995. If you have something for publication, please contact Bob Hansen, PSR editor at psr@tapr.org.* TAPR is looking for technical articles on the following subjects: information on general digital communications, applications using digital communications, equipment hints or modifications, future directions and standards, tutorials, and any regional packet news or information.

## ICOM IC-970 Modem Interfaces for Satellite Communications

Roy Welch, W0SL

This is not a 9600 modification. This is the procedure for setting the IC-970 up for 1200 bps PSK satellites.

**Do not use the IC-970 microphone connector for transmit or receive audio.** There seems to be too much audio shaping in this path. Use the DATA connector on the back of the IC-970. I have tried it both ways without much luck through the microphone connector. The DATA connector method works very well.

### PacComm PSK-1 Modem

1. IC-970 Interface - The IC-970 DATA connector leads to be used are as follows (see page 13 of owner's manual):
  - a. Pin 1 is transmit audio from the PSK-1 VHF RADIO connector pin 1 to IC-970.
  - b. Pin 7 is the push to talk lead from the PSK-1 VHF RADIO connector pin 3.
  - c. Pin 8 is the UP/DOWN lead from the modem to the IC-970. This lead is connected to the PSK-1 UHF RADIO connector pin 1. Install a 470 ohm resistor from pin 1 to pin 5 of the PSK-1 UHF RADIO connector.
  - d. Pin 9 is a ground lead to the PSK-1 VHF RADIO connector pin 2.
  - e. Pin 10 is the SUB band audio output from the IC-970 to the PSK-1 VHF RADIO connector pin 4. (See Note 1)
2. Set the PSK-1 parameter configuration as follows:  
MODE - SATellite  
MODEM - IN (in line)  
JT/SP - JOINT (for IC-970)  
AFC - USB or LSB (same as the mode selected on the IC-970)  
KC TUNER RADIO TYPE - NONE (not used at this station)  
RS232 SPEED - (RS232 port not used at this station)  
DCD SENSE - Use default except for the Kantronics TNC. (Doesn't seem to make a difference in Full Duplex mode).  
MAXIMUM STEP RATE - 12 steps per second  
MIC-CLICK SENSE - ACTIVE LOW (for IC-970)  
CLICKS-PER-STEP - 1

The PSK-1 allows about 150 to 200 hertz drift before frequency correction pulses begin. In the IC-970 in SSB mode, each pulse results in a 10 hz frequency change. Ten such pulses occur for each

change in the IC-970 frequency readout. The above arrangement will track an overhead satellite pass with maximum Doppler shift.

### TAPR PSK MODEM

1. IC-970 Interface - The IC-970 DATA connector leads to be used are as follows (see page 13 of owner's manual):
  - a. Pin 1 is transmit audio from the modem VHF RADIO connector pin 1 to IC-970.
  - b. Pin 7 is the push to talk lead from the modem VHF RADIO connector pin 3.
  - c. Pin 8 is the UP/DOWN lead from the modem to the IC-970. This lead is connected to the modem UHF RADIO connector pin 5.
  - d. Pin 9 is a ground lead to the modem VHF RADIO connector pin 2.
  - e. Pin 10 is the SUB band audio output from the IC-970 to the modem VHF RADIO connector pin 4. (See Note 1)
2. Construct the following circuit on a 12-pin header strip socket and install it on the combination JP5/JP6 plug in the modem:

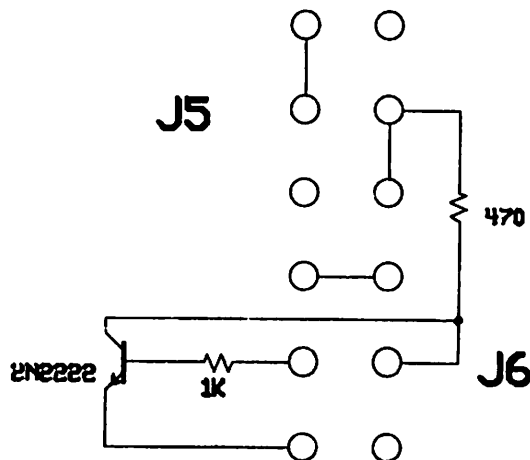

The TAPR PSK modem allows about 30 to 40 hertz drift before frequency correction pulses begin. In the IC-970 in SSB mode, each pulse results in a 10 hz frequency change. Ten such pulses occur for each change in the IC-970 frequency readout. The above arrangement will track an overhead satellite pass with maximum Doppler shift.

**Note 1:** The IC-970 DATA connector pin 10 only carries SUB band audio. In order to use your TNC for simplex (MAIN band) terrestrial packet communications you must obtain Main band audio from IC-970 DATA connector pin 5. This will require you to provide a means of switching the modem (PSK-1 or TAPR) VHF RADIO connector pin 4 to either IC-970 DATA pin 10 or DATA pin 5 for SUB band or MAIN band audio respectively.



**Note 2:** The IC-970 has an internal switch (see pages 13 & 42 in your owner's manual) which lets you set this input for 100 mv (default) or 3 mv. Placing a jumper on JP5 in the PSK-1 or JP7 in the TAPR PSK modem significantly increases the level of transmit audio from the modem which can then be adjusted with R40 on the rear panel of the PSK-1 or R6 in the TAPR modem. You should leave the IC-970 in the 100 mv input position in this case.

## IC-970 Modification For 9600 bps Operation

Roy Welch, W0SL

### Read all of this before starting any mods!

1. Prepare three lengths of small coax, each in series with a 10mfd non-polarized capacitor. The capacitors can be made an integral part of the coax using shrink tubing such that the braid of the coax and the one free lead of the capacitor extend from the end of the shrink tubing. The capacitor lead and the braid lead should be brought out of the shrink tubing, each inside of its own insulated sleeving. The capacitors provide DC blocking and the shrink tubing arrangement provides as small a package as possible at the Main circuit board end of the coax lead (space is a bit tight).
2. If you have the IC-970-H model, remove the power supply from the top and lay it over the side of the IC-970. This will reveal a metal tray beneath the supply. Don't drop the screws! It will be a real troublesome job trying to find them again down in the guts of the radio. Use a screwdriver with a screw holding attachment. It will be a real help.
3. Remove the metal tray from the top of the radio. Don't drop the screws. This will reveal the MAIN circuit board where all wiring will be done.
4. Remove all screws around the circuit board holding it to the radio. Again, watch the screws! By now you can guess that I dropped one.
5. Locate IC-11, IC-5, and D16. The Main Band receive FM audio is on pin 9 of IC-5. The Sub Band receive FM audio is on pin 9 of IC-11. The transmit audio is sent to the anode of D16.
6. You must turn the circuit board over to reach the foil side to make connections. This will require unplugging one or two of the interboard connectors.
7. Solder the capacitor leads of the prepared coax to pin 9 of IC-11, pin 9 of IC-5 and anode of D16. The connections may be made to any convenient spot on the foil that leads to the proper connection spot. The coax braid lead is soldered to nearby chassis ground foil. You will have to trace the ground foil from the nearest mounting screw hole out to where it comes near to the connection points. Check carefully for solder bridges, shorts, etc. Be sure to label the free ends of the coax NOW!! If you don't, you will kick yourself around the block when you get the board back in and then try to figure out which coax lead is which. Replace the board, routing the free ends of the coax to the right rear of the radio near the accessory socket. Don't drop the screws!
8. Remove the blank metal cover plate from the spare accessory plug holes in the back of the radio. Fabricate another cover (easy to do) so you can retain the original for replacement sometime when you sell the radio. Mount a small DPDT Radio Shack type switch on this metal plate so it protrudes from the rear through one of the two blank accessory holes. This switch will switch the 9600 audio output from either the Main Band (for terrestrial packet) or from the Sub Band (for satellite packet).
9. Wire the two receive audio leads and another short length of small coax to the switch so you can switch either of the receive audio leads to the short length of small coax. Solder the coax braids to the unused switch terminals. It is not required, but it is a nice place to terminate these leads. Replace the new cover plate with the switch protruding from the back of the radio. It is easy to remember the switch positions if you mount the switch such that toggle up is MAIN band and down is SUB band receive.
10. The D16 lead, and the now single receive audio lead from the switch will be terminated on two unused pins on the DATA socket on the rear of the radio. Connections will be made on the small circuit board attached to the data socket. This whole assembly can be removed by removing a couple of screws and one cable plug.
11. On the small circuit board find the pads that go to DATA socket pin 6 and pin 11 (currently not used). Solder the D16 lead to one lead of a 2200 ohm resistor and the other lead of the resistor to the pad going to pin 6 (resistor prevents loading down the regular mic audio). You can put this resistor in series with the capacitor at the D16 end if you wish and are neat about it. I personally feel it should be installed at the DATA socket as described so that if you ever want to change its value to help the transmit audio level on a stubborn 9600 modem, you won't have to worry about dropping screws again. Solder the receive audio lead to the pad going to

DATA socket pin 11. Solder both the coax braids to a nearby chassis ground pad.

12. CAUTION: Data socket pin 13 has 13.8 volts DC on it. It is a good idea to cut the solder side of this pin or otherwise insulate it on any plug you plug into the DATA socket. The spacing is close and soldering to the 13 pin "DIN" plug is rather trying. You DO NOT want 13.8 volts DC getting shorted to something and vaporizing a foil trace in your radio or otherwise going into your 9600 modem by accident.

13. We used this arrangement at the Soviet Space Exhibit and it worked fine. I have made mods. to both the H and A models of the IC-970. Good luck and have fun (you will if you don't drop any screws).

---

## User and Development Interfaces for the DSP-93

The following two articles describe the D93WE (Windows Environment) and DSP-93Control (Macintosh Environment) programs for the TAPR/AMSAT DSP-93 digital signal processing unit. D93WE was written by Tom McDermott, N5EG, and DSP93Control was written by Ron Parsons, W5RKN. Both of these applications bring the full power of the DSP-93 to your computer's desktop. TAPR and AMSAT would like to thank both Ron and Tom for their time and effort in developing these applications.

---

### D93WE: A Windows Development Environment for the TAPR/AMSAT DSP-93

Tom McDermott, N5EG

This article describes the D93WE (DSP-93 Windows Environment) program, a Windows development environment for the TAPR/AMSAT DSP-93 digital signal processing unit. The purpose of the development environment is to provide the following features in an easy-to-use point-and-click Windows interface:

- Download of already-assembled software to the DSP-93
- Fast, efficient Edit/Assemble/Download cycle for development of TMS320C25 assembly programs
- Various utility programs, such as oscilloscope, function generator, and spectrum analyzer
- Integrated communications terminal that operates at 19 Kbaud, including Cut, Copy, Paste, Clear, Search, etc.

The program runs on a PC or compatible computer running Windows 3.1. It is written in Borland C++ version 3.1, and uses the Object Windows Library (OWL), version 1.0. The OWL is an object-oriented interface to Windows, and provides a clean, robust implementation. Several design issues arose with the choice of the OWL interface to Windows, but the speed of development effort and the solidness of the application are attributable to the choice of this package. The total software package is about 4,000 non-comment source lines of code, including C++, TMS assembly, and resource files. The D93WE package is provided along with the DSP-93 unit by TAPR.

### DSP-93 Hardware

The DSP-93 was developed by Bob Strickland, N5BRG. It is a powerful, general purpose DSP board set based on the Texas Instruments TMS320C25 processor. Several analog interface boards have been planned, the one currently available is a voice-frequency board optimized for audio-bandwidth signal processing, and optimized for interconnection to various radios at audio frequency. This analog board is based on the Texas Instruments TLC32044 converter (CODEC) IC. This IC contains anti-aliasing filters, a 14-bit A/D, a 14-bit D/A, and reconstruction filters. The sample rate and the bandwidth of the filters are programmable, but not with very much resolution. Due to the low resolution of the 32044 counters, and difficulty in changing the sample rate, the sample rate was held constant, and much of the software selectively discards samples in order to alter the effective net sample rate.

### DSP-93 Software

The TMS assembly code makes use of the excellent monitor ROM in the DSP-93, providing many of the needed interfaces between the DSP-93 and the Windows program. The monitor ROM provides a software download capability, and the ability to start an application. It also provides calls to allow receiving or sending ASCII characters between the DSP-93 and the Windows program, and it provides a call to reset the DSP-93 back to the monitor.

The four DSP software programs that were developed to support the Windows D93WE application consist of four TMS assembly modules:

- Sampling Oscilloscope
- Function Generator
- Spectrum Analyzer
- Memory Test

## Sampling Oscilloscope

The sampling oscilloscope is a simple idea, with a few complications. The Windows code first downloads the program to the DSP-93 and starts it, then waits for the user to click a button. The START button initiates sampling by the DSP-93. D93WE sends a parameter-block (some ASCII hexadecimal characters) to the DSP-93 that define the sampling interval, trigger level, trigger slope, voltage gain + port selection, and auto-trigger flag. The DSP-93 software sets the A/D to sample at a 62.5 kilosamples/second rate. However, the software discards most of the samples. The more it discards, the slower the net sampling rate. When you choose the sweep rate on the oscilloscope, you are setting the number of samples that the DSP-93 throws away between samples that it keeps. The trigger logic is what causes the scope to start the sweep at the same point on the waveform every sweep. The trigger level is a binary number that equals the equivalent voltage that the sweep will start at. The slope determines whether a positive-going or a negative-going voltage will start the sweep when the trigger level is crossed. The program receives each sample during an interrupt and compares it to a previous sample saved from the last valid sample time. If, for example, the positive slope is set, then if the old sample were below the trigger level and the new sample is above the sample level, then the scope is triggered, and samples will be acquired.

Autotrigger prevents the scope from waiting forever if no signal ever meets the trigger criteria. In this case, it keeps count of how many times a comparison is made against the trigger criteria and fails. After a large number of comparisons fail, it goes ahead and triggers the scope anyway. This is useful if you want to see what is on the scope input, but you are not sure where to set the trigger level. It may be useful to turn off auto-triggering if you want the scope to wait, possibly a long time, until just the right trigger condition is met. This can be handy for capturing seldom-occurring transient events when the scope is in the single-sweep mode. Once the scope is triggered, the program acquires 512 samples from the A/D converter, storing them in memory. Once all 512 have been stored, the program converts them to ASCII-hexadecimal, and sends them to the PC on the serial cable. After it completes the sending, it sends the letter 'Q' to signify end-of-block. During Beta-testing, some PCs would occasionally drop characters at 19.2 kilobaud, and the program would lock up waiting for all 512 samples to be received. Now, the PC checks for the 'Q' character, and assumes the sweep is complete even if less than 512 samples have been received. This problem is well-known for certain

80X86 processor / serial I/O chip combinations when running at 19.2k baud under Windows.

The port selection and gain values select the programmable-gain multiplexer, and the input port selection multiplexer on the DSP-93. The DSP-93 can select one signal from up to eight inputs, and has 4 gain values usable by these applications.

## Function Generator

The function generator program is downloaded from the PC to the DSP-93 and then started. It is based on a numerically controlled oscillator, or NCO. Basically, the D93WE program sends the DSP-93 some parameters (like in the scope program), one controls how fast the NCO accumulates, one determines the amplitude, and one determines the type of waveform. The NCO works by accumulating phase. The D/A converter is set to interrupt the TMS320C25 processor at a 62.5 kilosamples / second rate. During each interrupt, the software adds a phase-increment value to the current phase value of the NCO, the NCO rolls-over upon reaching 65536 (a 16-bit accumulator). So, the larger the increment value, the faster the NCO accumulates phase, and the faster it rolls over thus producing a higher frequency. The value of the NCO register at any time is proportional to the phase of a signal, with 0000h representing 0 radians, and 10000h representing 2-PI radians. Thus the NCO continually increments from 0 to 2-PI, rolls over to a small number (the remainder), and keeps increasing.

A large part of this DSP-93 program consists of 4 tables in memory, that are downloaded along with the actual program software. One table converts phase to sinewave-amplitude, one converts phase to trianglewave-amplitude, one converts phase to squarewave-amplitude, and one converts phase to sawtoothwave-amplitude. Each table contains 256 entries, corresponding to a few degrees resolution of a complete cycle. The program in the DSP-93 looks-up the amplitude corresponding to the current phase in the NCO, and then multiplies that amplitude number by the output amplitude level setting. The product of these two generates an amplitude with a great deal of resolution and adjustability. Unfortunately, the 256-word tables provide a fair amount of aliasing, and the resulting waveforms have some severe beat-notes associated with them. Higher resolution tables would improve this, but the download time would be very long. So 8-bit (256-entry) tables are the compromise. The sinewave has fairly low distortion over much of the frequency range, but the triangle, square, and sawtooth waves are distorted at the higher frequencies, and when close to subharmonics of the sampling frequency. The

TLC32044 CODEC chip filters, and the limited table resolution prevent the function generator from operating well above about 800 hertz, except for the sine wave which works well to much higher frequencies. The low-frequency usefulness is determined by the AC-coupling capacitors on the DSP-93. In fact, the low-frequency performance of the DSP-93 can be substantially improved if the AC coupling capacitors are replaced by small-value resistors. However, if you do this, be careful not to apply excessive DC voltage to the I/O pins, or you may damage the CODEC IC.

### **Spectrum Analyzer**

The spectrum analyzer operates much like the oscilloscope, and in fact, uses much of the same logic as the scope. The D93WE program forces the trigger level to zero, and the slope to positive. After the program captures a complete buffer of 512 samples in memory, it performs a Discrete Fourier Transform (DFT) on the sample set. The DFT is much simpler (and slower) than the Fast Fourier Transform (FFT) but yields the same results. Normally, the FFT is used when speed of the transform is important. However, the limiting factor in speed is the 19.2 kilobaud serial interface to the PC, not the processor speed. The DFT calculations are overlapped with the sending of the serial characters to the PC, with the result that the computation time is mostly happening while the DSP-93 would be otherwise idle waiting for a character to be completely sent to the PC at 19.2kbaud.

The DFT computes both a real and an imaginary value at each given frequency. Since the A/D converter on the DSP-93 captures only one sample per sample-time, the input is real-valued. This means that the Fourier-transform contains a mirror-image of the DC-to-one-half sampling frequency values in the range of one-half-sample-rate to  $f$ -sample. So, we can throw away the upper half of the spectrum, since it's merely an alias of the DC to  $1/2 f$  sample spectrum. This results in the DSP-93 program sending each frequency sample pair (real, imaginary) to the PC, for a total of 256 pairs, or 512 samples. This is the same total number of characters as the scope program sends, so the spectrum analyzer runs at about the same speed as the scope. Some care has to be taken to properly scale the A/D samples, and the range of the sine and cosine tables to prevent numeric overflow in the DSP-93 during the computation. The PC program has to receive the sample pairs, and generate the magnitude of the signal (see below).

### **Memory Test**

A useful program tests the RAM memory of the DSP-93 unit. This proved to be invaluable late in the beta-test program. The program runs seven tests:

- All-zeros to DATA RAM
- All-ones to DATA RAM
- Unique pattern to DATA RAM high-to-low
- Unique pattern to DATA RAM low-to-high
- All-zeros to PROGRAM RAM
- All-ones to PROGRAM RAM
- Unique pattern to PROGRAM RAM high-to-low

The all-zeros and all-ones programs usually detect a stuck bit in a RAM chip. A stuck data line or two shorted data lines would prevent the DSP-93 from operating at all. The unique pattern, however, is very powerful at finding a number of different faults, and is highly recommended. Since the 320C25 is a 16-bit processor with 64k address spaces (DATA and PROGRAM), the unique pattern is nothing more than the value of an address written as data at that address. All addresses are written, then all read back and tested. If address lines are stuck or open, this test will usually find it. In the final testing of the beta-units, a subtle hardware timing problem was discovered by this test, with the result of the bug being that writing certain addresses changed the data values in unrelated other addresses! One of the GALs (Generic Array Logic, 22V10) on the DSP-93 was reprogrammed before the production units were shipped, and it solved the problem.

### **Windows Display Software**

The windows program coordinates the DSP-93 instruments by sending parameter blocks to the instruments each sweep period, or updating the parameter values for the function generator if the user changes the sliders associated with frequency, amplitude, or changes the wavetype selection.

### **Oscilloscope**

This program, when started, sends a parameter block to the DSP-93 to start a sweep, along with the sweep rate, trigger, level, slope, gain, port number, and autotrigger flag. If the PC is in the recurrent sweep mode, then each time after the DSP-93 triggers and sends the acquired values back to the PC, the PC will send a new parameter block back to the DSP-93, starting a new sweep. If the PC is in the single-sweep mode, then the PC will not send a new block. The user will have to click START to get going again. The display contains some grid lines (in blue) that set the horizontal and vertical divisions on the scope face, and a red horizontal line, that can be moved up and down with the trigger-level selection. This way, the trigger level can be visually adjusted just by looking at the

Figure 1:

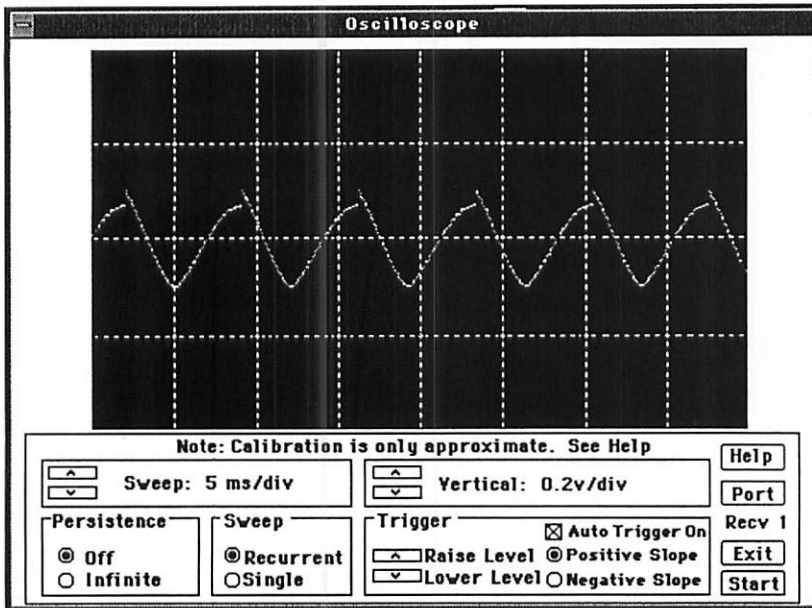

receive signal. In the single sweep-mode the screen is erased when the parameter block is sent to the DSP-93, so you will have some visual feed back if the DSP-93 did or did not trigger. This is very useful when autotrigger is turned off since you may want to setup to trigger on a rare event, and if you see a sweep, you know that it triggered.

Another very useful feature of a digital scope, is that the previously displayed samples do not always have to be erased between sweeps. If the INFINITE PERSISTENCE button is checked, then the samples are not erased between sweeps. This is most useful if the scope is reliably triggering. It can identify jitter, and other problems with received waveforms. It also allows an extremely simple eye-pattern monitor. If you capture some positive going and some negative going sweeps in the infinite persistence mode, you will effectively have an eye-pattern. This may be more useful, however if triggered off a signal without any jitter, which seems like a future instrument possibility (one to phase-lock a DSP-93 clock to the received signal with a low-bandwidth PLL, trigger off of the PLL, and then display the received signal). Figure 1 shows the Oscilloscope display.

### Function Generator

The windows program to display the control panel for the function generator is not very sophisticated, and just allows modification of the parameters, which are sent to the DSP-93 any time the controls on the pop-up panel are adjusted.

### Spectrum Analyzer

The spectrum analyzer program is very similar to the oscilloscope program, except that it has to do some processing with the received signal pairs. Recall, the DSP-93 sends (real, imaginary) pairs to the PC. The spectrum analyzer computes the magnitude (square-root of real-squared plus imaginary-squared) and displays that value. There is a linear and a log mode for display. The PC displays a scaled value directly to the screen in the LINEAR mode, while in the LOG mode it computes the LOG of the value, and then scales that value before displaying it on the screen. The persistence modes are different for the spectrum analyzer than for the oscilloscope. The display is always erased between sweeps, regardless of the persistence mode. However, in the MAX-HOLD mode, the PC keeps a

running maximum of the magnitude of each frequency bin, and selects either the maximum of some previous sample or the current sample (whichever is greater). When the MAX-HOLD button is initially clicked, the register is zeroed out for all 256 frequency bins. This mode is useful for watching sporadic frequency components that pop up every once in awhile. The INTEGRATE mode instead integrates the new magnitude for each frequency bin with the previous values for that same frequency bin. It does this by a process known as exponential integration, since it settles to a final value much like a single-pole integrator does. 1/16 of the new input magnitude is added to 15/16 of the current integrated value. This is useful for suppressing random noise in the LOG displays, since the noise averages out while the signal continues to accumulate. You can sometimes see signals 'grow' out of the noise in this mode. The integrator is not zeroed when this button is clicked, because it takes too long for the integrator to settle out. Instead, the current sweep value is loaded into the integrator, so it settles from the current value. This results in a much faster integration to the final value.

The reason it was chosen to have the PC compute the magnitude of the frequency bins is that at some later time, the program could be easily modified to display the real and imaginary parts, or to display the magnitude and phase parts of the Fourier transform. The DSP-93 software would not have to change. Figure 2 shows the spectrum analyzer display.

Figure 2:

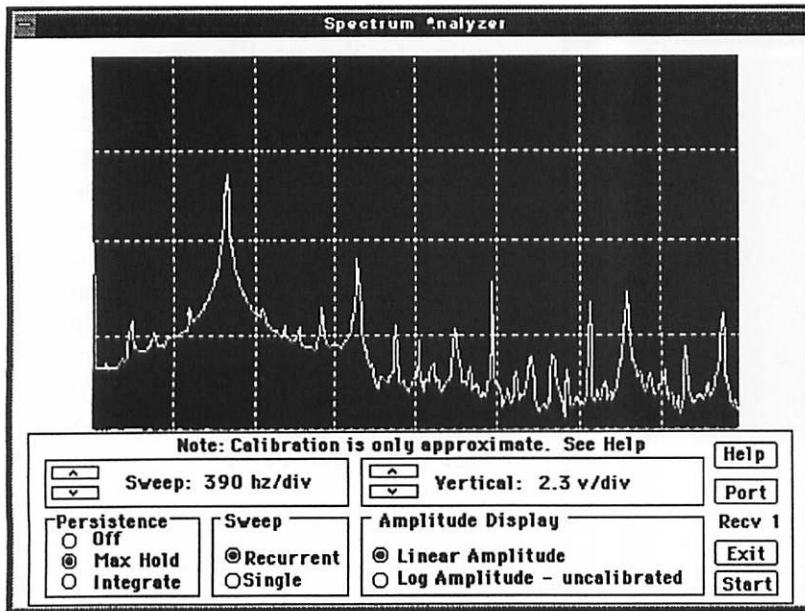

### Other Windows Functions

Since the windows program will be used by people with a wide variety of experience, it was decided to provide several different ways to download software. Extremely useful feedback from the beta testers provided the insight to this. Casual users just want to point and shoot at the program they want to download. So a menu with a drop-down file browser is provided.

Some people like to configure their applications, so a user-configurable menu was provided. This allows you to specify up to ten program titles (more descriptive than the file name) along with ten associated files in the D93WE.INI (initial settings) file. Then you can have your menu say anything you like, and when you click it, some associated program will be downloaded to the DSP-93 and executed. This could be set up, for example, to display up to ten different modems for the DSP-93, and then you could select each modem with one mouse click.

Finally, the third way to select the program is very useful to program developers. In this mode, you select the name of some DSP-93 assembly program you are working on in the SET-PROGRAM-NAME popup of the DEVELOPMENT window. Then, one mouse click invokes a user-specified editor with that file opened for edit. Another click causes that program to be assembled (with user-adjustable parameters set once in another window). A shareware assembler is available, the

actual assembler launched is configurable within the D93WE.INI file. A single click to a third menu downloads the newly assembled program to the DSP-93 and executes it. This EDIT-ASSEMBLE-DOWNLOAD cycle is very fast, and removes much of the tedium from writing and testing the code. Another single mouse click will allow you to view the assembled listing file, which is sometimes useful. The notepad editor that comes with Windows is nice for this edit function, but I have found the PFE (programmers file editor) a freeware (not shareware) program available on Internet to be much nicer, and with many useful features.

### Terminal and Implementation Notes

The D93WE program contains a built-in terminal for displaying the results of serial input and output with the DSP-93. In OWL/C++, it is very simple to include the functionality of a full-screen editor in the program. When writing C++ code, you just 'inherit' your application object from a full-screen editor object, and then anything the editor can do, your new application can now also do! Unfortunately, the stock Borland OWL TEditWindow object lacks any serial I/O capability, so some slight trickery is needed to give it those functions - the TEdit object had to be replaced with a new object (derived from TEdit) that knows what to do with keystrokes. This turned out to be a significant amount of effort to get working properly on all the various different

Figure 3:

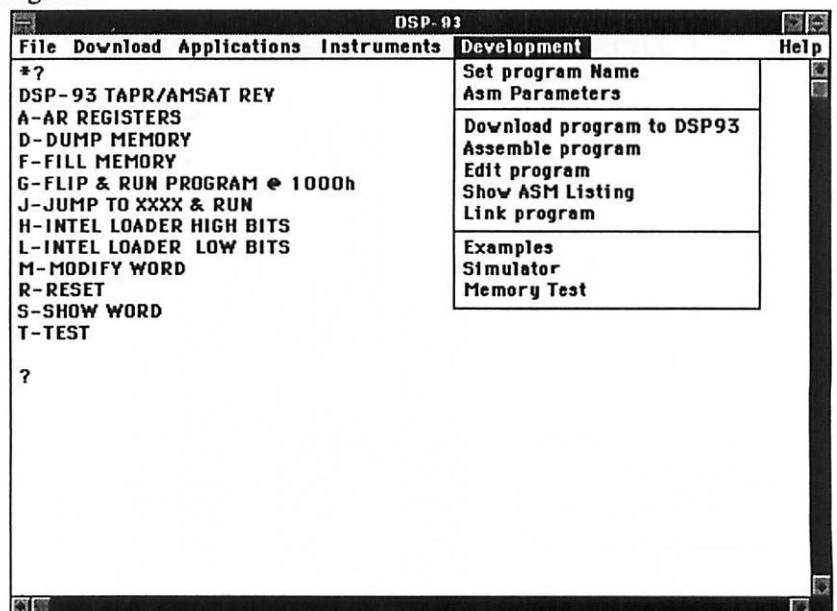

computers that our beta testers had, but the result was worth the trouble. The terminal window inherits the Cut/Copy/Paste capability of its base class, and so you can cut and paste the terminal window contents to/from the clipboard. It also inherits the Search/Replace capability of its base class so you can search the terminal window for a specific character sequence. This proved useful when looking through the monitor code one night for TMS320C25 RETURN instructions while debugging some assembly code.

Another class (a C++ object definition) that proved to be useful was a TInstrument class. It was derived from a TDialog object (a Windows dialog-box), and then given a virtual function to handle received serial I/O from the DSP-93. The class was made pure-virtual (meaning you can't instantiate a TInstrument, you must use the TInstrument to derive yet another object, in C++ lingo, the TInstrument is a virtual base class). However, all the instruments (scope, function generator, and spectrum analyzer) are objects derived from the TInstrument object, and thus they all inherit knowledge of how to receive control from a timer, and they know how to handle serial reception. The main program just hands control over to the current instrument, whatever that may be, and everything sort of happens correctly by magic. A far cry from monstrous switch statements used when writing C-based Windows programs.

### On Line Help

The D93WE program contains extensive on-line help, using the Windows standard help system. Additionally, the three instruments contain context-sensitive help directly from the control panel of the instrument. I have found that writing and debugging the HELP system while simultaneously developing the program resulted in comprehensive help text. Certainly, some important topics would have been forgotten if the help system had been put off until the end. The whole package was developed as a series of prototypes, with additional functionality in each test release. Constructive feedback from the beta-testers helped in establishing many of the features of the current version. Help matched each version, so the beta testers tested not only the program, but the usefulness of the help system at the same time. Unfortunately, not all of the beta-testers actually read the help before asking questions, but this probably is an accurate representation of how the final users will operate the program! The on-line help is extensive enough that a printed manual was deemed not necessary by some of the users (those that used the on-line help, I hope).

### Acknowledgements

I would like to thank Bob Stricklin, N5BRG for his assistance, and to the DSP-93 beta testers who tried all sorts of PCs and combinations that I would not have thought of, and who provided many useful comments, suggestions, and ideas for improvements.

Note: D93WE is copyright ©1994 Tucson Amateur Packet Radio Corporation.

---

## DSP-93 Control: A Macintosh Development Environment for the TAPR/AMSAT DSP-93

Ron Parsons, W5RKN

This article describes the DSP-93Control application, a Macintosh interface for the TAPR/AMSAT DSP-93 digital signal processing unit. The purpose of the interface is to provide the following features for Macintosh users:

- Download of already-assembled software to the DSP-93, either in Macintosh or DOS file formats
- Fast, efficient Edit/Assemble/Download cycle for development of TMS320C25 assembly programs
- Various utility programs, such as oscilloscope, function generator, and spectrum analyzer
- Integrated communications terminal that utilizes the Apple Communications Toolbox.

The program runs on a Macintosh computer running MacOS 7.0 or later. It is written in MPW C++, and uses the MacApp object framework, version 3.0.1. The framework is an object-oriented interface to the MacOS, and provides a clean, robust implementation.

This article should be read in conjunction with the previous article D93WE - a Windows Development Environment for the TAPR/AMSAT DSP-93 by T.C. McDermott, N5EG. Both that program, and the application described in this article were written to provide similar functionality to users of the DSP-93 in different computer environments. Thus I will describe only unique elements of this application or elements which were implemented differently.

### The Integrated Terminal Emulator

When this application is launched for the first time, the user is asked to configure the serial port used by the terminal emulator. Because the Apple Communications Toolbox is utilized, any serial port on the Macintosh may be used, even additional serial ports provided by add-in serial interface cards. Baud rates up to 57.6 kbs may be specified although the default rate of 19.2 kbs will probably be used for the DSP-93. The baud rate may be changed on the fly by

Figure 4:

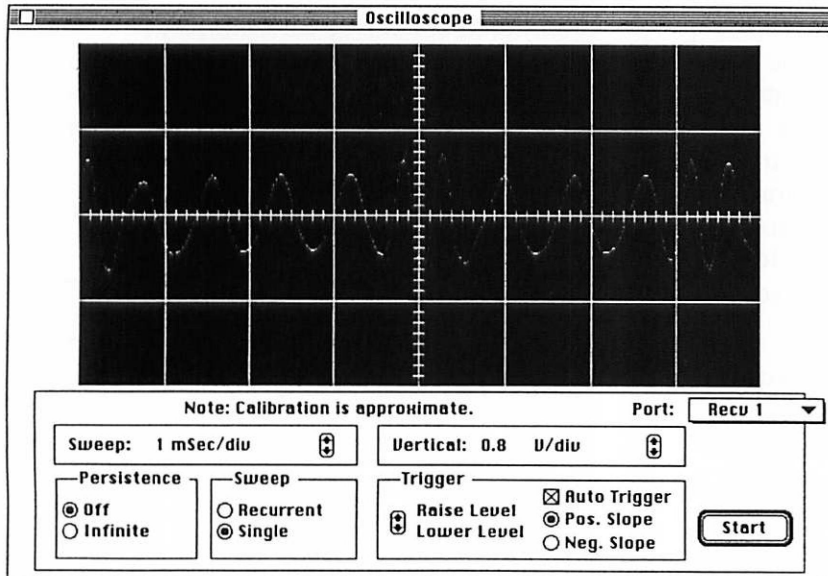

sufficient to assemble many simple programs including all the test programs provided with the DSP-93.

The output of the assembler is written to the same folder that contains the assembly source file. The object file name is the same as the assembly source file name with .OBJ appended. The listing file name is the same as the assembly source file name with .LST appended. Both files are Macintosh format files (the line end character is an ASCII 13 (CR)). The user is informed about any errors which may have occurred in the assembly. The listing file may be opened in the integrated text editor.

### Running Programs on the DSP-93

The application can download programs to the DSP-93 using object code in either DOS format files (the line end character is an ASCII 13 (CR) followed by an ASCII 10 (LF)) or Macintosh format files (the line end character is an ASCII 13 (CR)). Two menu items are provided for this in the Actions menu.

The program downloaded to the DSP-93 is automatically executed on completion of the loading sequence.

choosing DSP-93 Serial Configuration from the Settings menu. A maximum of about 32000 characters are retained in the scrollable terminal window. Text may be selected and copied to the clipboard, but the characters in the terminal window may not be altered.

A menu item in the Settings menu is provided to let the user choose whether to echo characters typed into the terminal. This option should not be chosen for the DSP-93 as that unit echoes the characters.

### The Integrated Text Editor

An existing text file may be opened by choosing Open from the File menu. New text files may be created by choosing New from the File menu. The editor is a full-featured text editor following the Macintosh user interface guidelines. Styles, copy, paste, undo, and search and replace are supported. A maximum of about 32000 characters is supported in each file. An arbitrary number of text editing windows may be opened simultaneously. Printing to the chosen output device is supported.

### Assembling Programs

An integrated assembler for the TMS320C2x is provided by choosing the Assemble item in the Actions menu.. The assembler does not handle the #include macro (actually it does if you precede the # with a space - it works but gives an error message). The assembler does not handle all expression operators and other niceties that the DOS based TASM 3.0 does. It is

### The DSP-93 Instruments

The same three instruments, Sampling Oscilloscope, Spectrum Analyzer, and Function Generator, that are described in the D93WE article are supported by this application. The interface and

Figure 5:

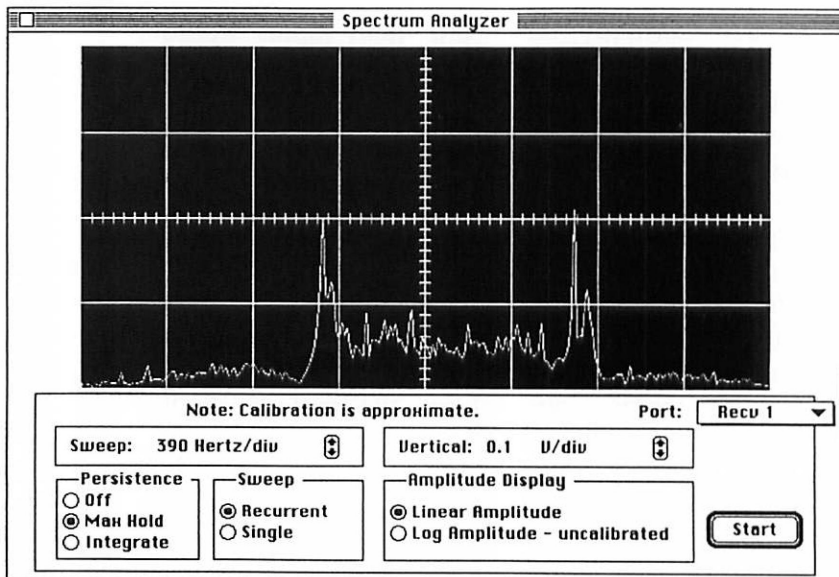



window appearance are virtually identical. See the D93WE article for a full discussion of the instruments.

The instruments are loaded and executed by choosing an instrument in the Instruments menu. This application assumes that the Macintosh version of the object files supplied with D93WE are to be loaded. If the appropriate object file is not found in the folder that contains the DSP-93Control application, the user is asked to locate the appropriate object file. Figure 4 shows the Macintosh Oscilloscope interface displaying a 1200 bps packet audio signal. Note the two different periods of the waveform corresponding to different binary digits. Figure 5 shows the Macintosh Spectrum Analyzer displaying a 1200 bps packet audio signal. Note how the two peaks corresponding to the low and high tones of the AFSK signal are displayed.

### The Future

I would like to provide an assembler with more complete functionality. If you know of C source code for such a beast, please let me know.

### Acknowledgements

I would like to thank Tom McDermott, N5EG, for writing the DSP-93 instruments and documenting their interface so clearly. I would also like to thank Bob Stricklin, N5BRG, for his loader code for the DSP-93.

Although this application and D93WE were developed independently, there is an amazing similarity in the source code of the two programs. This is most likely due to both of us using an object-oriented application framework. If anyone has the inclination to develop software for today's GUIs, I strongly urge you to learn and use an object framework. Although the learning curve may appear steep, the results, once you are able to see over the peak, are worth it.

---

## Packet Radio and TAPR are on the World-Wide-Web!

The series is accessible through the Packet Radio Home Page at these URLs:

<http://bb.iu.net/infomotion/taprhome.html>

<http://bb.iu.net/infomotion/pkthome.html>

What's here? A page of links (the Home Page), the TAPR Home Page, a page of Packet Pioneers and Contacts, a hypertext packet primer and FAQ, and more. Thanks to Howie, N2WX, President of Infomotion, for his support and invaluable contributions of the TAPR page.

## High Speed Topics

N6GN has built a WWW page for some of his higher speed Amateur networking pursuits on:

<ftp://col.hp.com/hamradio/packet/n6gn/index.html>

Currently it contains papers, information, drawings and schematics related to:

ARRL Conference Papers  
900 MHz Antenna Designs  
Multi-Megabit Microwave Link  
Bit Error Rate Tester  
"Layer 3 TNC" Project

Updates will be made as time permits. Thanks to:

Glenn Elmore, N6GN

amateur IP: [glenn@SantaRosa.ampr.org](mailto:glenn@SantaRosa.ampr.org)

Internet: [glenne@sr.hp.com](mailto:glenne@sr.hp.com)

---

## DRSI Ends Sales of Ham Products

*[Information from Andy Demartini, [aed@drsi.com](mailto:aed@drsi.com)]*

Some time ago, DRSI notified all of its dealers that it has discontinued all Amateur radio products. DRSI will continue to provide repair service and telephone support for its Amateur products in the field, but we have retired the designs and no more will be built.

DRSI is providing full telephone, fax, and e-mail support for its customers. We are also repairing broken products both in and out of warranty. We are open 9-5 EST, Monday to Friday, and have installed a voice mail system for after-hours support.

For the last four years of DRSI's eight years in business, we have been developing industrial packet radio products and making a name for ourselves in those markets. For the last two years, we have steadily reduced our Amateur advertising and hamfest promotions. On October 1, 1994, dealers were notified that DRSI was ceasing further manufacture of Amateur products. From this point forward, DRSI will focus entirely on its industrial products for the "wireless revolution."

The decision to cease Amateur production was made to allow DRSI as a company to focus all of its resources, both human and financial, on industrial products. The simple truth is that the industrial markets place a significantly higher value on our knowledge and expertise. This added value results in a markedly better return on investment. So, we have made a hard choice, but one which will result in better returns for the people who give us their 8-, 12- and 16-hour workdays.

# PacComm presents the PicoPacket

(Come see the PicoPacket and chat with us at the TAPR Annual Meeting)

Check out the new **PicoPacket** from PacComm. It sure is cute! Call it the Pico, or the PicoPacket or Pico TNC (say peeko tink).

Modern surface mount construction techniques are used to reduce the size to 1 x 2.5 x 3.0 inches, only 123 cc (7.5 cu. in.). By comparison a pack of Marlboro 100s are 125 cc and PacComm's popular HandiPacket is 246 cc. The TNC-1 in 'Gucci cabinet' was over 5000 cc!

The size comparison is even more impressive when you consider the size with cables attached. RJ-45 connectors are used for both terminal and radio cables to avoid normal cable connectors which are nearly as large as the Pico itself. These are the same type of connectors used on LAN wiring and radio microphones. So a PicoPacket with both radio and terminal connectors attached is still only 125cc.

**PERFECT FIRST TNC.** Every feature you'd expect on a 'normal size' AX.25 1200 baud TNC plus **ON-LINE HELP**.

Type Help and a command name (or partial name) and receive the proper spelling and shortest abbreviation of the command, default value, acceptable values, and an explanation of the command function. Can also list all commands or various subsets of commands.

**MODERN DESIGN.** Uses the Z-181 high integration processor with one megabyte address space and built in enhanced 8530 (ESCC) HDLC port. A socketed conventional DIP 64k byte EPROM is used for easy firmware upgrading.

32k RAM is socketed for easy user upgrade to 128k (or order it with 128k already installed). Optional large RAM board carries either two 128k RAMs or two 512k RAMs.

**GPS PORT.** The full-time GPS port option implements a second asynchronous serial port which can operate at either RS-232 or TTL levels for attachment to any portable GPS receiver.

**SMART BATTERY.** The optional 'Smart' battery pack uses two inexpensive AA cells to generate 5VDC. This smart battery pack may have many other applications around your hamshack!

**MATCHING GPS RECEIVER.** Trimble SVEE6-CM2 GPS receiver in a matching case only 1 x 2.5 x 3.25 inches. Attaches to the GPS option board in the PicoPacket with a simple 3.5 mm stereo cable.

Standard accessories:

- RJ-45 serial cable with adapter to DE-9.
- RJ-45 radio cable (solders easily to radio connectors).
- Power cord.
- Manual, schematic, Quick Command listing.

Options:

- 128k RAM, 512k RAM or 1mb RAM.
- Full time GPS port.
- Smart battery pack.
- GPS receiver in matching case.

## News from PacComm

Gwyn Reedy, W1BEL

Hot news: The imminent availability of the PicoPacket. We'll be showing it at the TAPR meeting and shipping soon after.

It will be followed by at least two more new PacComm multi-port, multi-speed, multi-mode designs for 1995 which will use a Z-180 family processor (Z-181 or Z-182). Look for another new product announcement in the next PSR.

Z-181/2 advantages: 1) Uses the Z-80 instruction set (with extensions) so existing code may be easily ported. 2) Available with clock rates up to 33 MHz at reasonable cost. 3) Has embedded ESCC port(s) for HDLC which have improved buffering and controllability compared to the SIO or SCC. 4) Has several embedded serial ports and a parallel port, thus reducing parts count (i.e. cost). The PicoPacket, for instance, has only 5 ICs, not counting RAM and ROM.

Disadvantages: 1) Its only an 8 bit microprocessor. But that's not much of a limitation. Look at racing cars - Toyota rules the Unlimited class with a 2 liter turbocharged four cylinder engine. It runs away from the 7 liter Chevy V-8 powered cars with twice the number of cylinders. Same for microprocessors - you don't necessarily need 16, 32, or 64 bits to be powerful! 2) The more sophisticated Z-18x designs are only available in surface mount packages. That is a disadvantage to the home builder, but with PacComm's new high-capacity surface mount assembly line, it means lower production costs, which are passed along to the customer.

Taking care of the experimenter department: PacComm still offers the original TNC-2 circuit board and manual for builders. We have

offered this product continuously since 1985 and have no plans to discontinue it!

The SPRINT-2 High Performance Packet Controller has been renamed the SPIRIT-2 High Performance Packet Controller. Seems U. S. Sprint felt this product was a threat! Here's a quote from their legal department's letter to PacComm:

"Your use of SPRINT-2 is misleading and is likely to cause confusion among the customers of the products and services of Sprint and its subsidiaries and those of your company."

Our reply: "We credit our customers with more savvy than you apparently do yours. It is intuitively obvious from our literature and from the bold PacComm logo on the front of the SPRINT-2 that this product is from PacComm, not Sprint."

Being realists, and in light of the disparity in size of U.S. Sprint's and PacComm's legal staffs (we don't have one), we changed the name to SPIRIT-2. It is still the high performance and value leader!

DRSI has publicly announced their exit from the amateur radio market. No need to fret. PacComm offers products similar to nearly all of DRSI's past offerings, including the DRSI specialty - the dumb PC HDLC card. PacComm's repair department is able to repair DRSI amateur products too.

Ask for a copy of PacComm's catalog.

**PacComm Packet Radio Systems, Inc.**  
4413 N. Hesperides St., Tampa, FL 33614-7618  
Voice: +(813) 874-2980 Facsimile: +(813) 872-8696  
BBS: +(813) 874-3078 CompuServe: 76576,2003  
Internet: info@paccomm.com  
Catalog Requests & Orders: (800) 486-7388  
(Two lines with 24 hr. voice mail)

## The Powerful, Easy Way to Build a Network Node Stack



The photograph above shows three SPIRIT-2 High Performance Packet Controllers linked via the internal CoaxLAN and a simple two wire cable.

Advantages:

- 1) As in other node stacks you get the redundancy of a separate processor for each channel. If one TNC fails, the rest of the stack continues in operation.
- 2) Using the SPIRIT-2 you gain the power of a 10 MHz CPU with expansion capability to 20 MHz. All the power you need for faster data rates in the future. And the SPIRIT-2 modem upgrades to 19.2, 38.4, or 56kb with only plug-in components.
- 3) See how simple the CoaxLAN makes interconnecting node TNCs. It couldn't be much easier (or work any better).

## TAPR TNC-2 Release 1.1.9

TAPR is proud to announce the release of version 1.1.9 for the TNC-2. 1.1.9 EPROMS with command booklet will be available from the office in January. 1.1.9 will replace the current 1.1.8a being distributed by TAPR.

Release 1.1.9 incorporates these new features:

- NMEA beaconing mode
- Enhanced monitor mode filtering
- Support for Dallas Semiconductor "Smartwatch" (tm) socket
- CW identification in FSK using the onboard packet modem

And these changes:

- The pound sign ASCII character "#" is allowed in callsigns
- The "OUT" command installed in version 1.1.8 was removed

### NMEA Beacon Function

TNC-2 now incorporates a dedicated mode enabling the broadcast of one or two NMEA version 2.00 (and compatible) sentences to the UNPROTO address. When placed in NMEA mode with a non-zero value in the NMEABCN parameter, the TNC broadcasts the most recently received sentences received from the attached NMEA talker. No other outgoing transmissions are permitted with the exception of identification, beacon, CTEXT, and mailbox data (if supported).

NMEA devices provide an ASCII output at 4800 baud, 8/N/1, consisting of one or more types of sentences containing various types of data. Most commonly these data contain navigation fixes. For example, the author's global positioning system receiver (Garmin model GPS-55AVD) generates sentences containing the receiver's longitude and latitude (fix), time of the fix, groundspeed, waypoint data, and the like.

An example:

```
$GPRMC,034523,Y,02754.31,N,08023.03,W,1.5,035,031294,4,W*23
```

Meaning:

"\$GPRMC" - Indicates the type of data (RMC-minimum recommended GPS sentence)

034523 - UTC hh/mm/ss

Y - data valid

02754.31,N - longitude

08023.03,W - latitude

1.5 - groundspeed

035 - Track made good over the ground (degrees true)

031294 - date ddmmyy

4,W - magnetic variation, West

23 - checksum (ignored by the TNC)

### MNONPRIN ONIOFF default: ON

The TNC will examine the contents of each monitored packet for nonprinting ASCII characters and discard the entire packet if at least one is detected. Nonprinting characters means any ASCII character less than the space character except for BELL, LF, CR, and the DEL character. The test occurs after masking off the high order bit. By setting MNONPRIN to OFF, and in concert with MNONAX25 OFF, the TNC will filter nearly all screen-garbage inducing monitored packets.

### CWID ONIOFF default: OFF

FSK CW identification is now available. When CWID is ON, the string in the IDTEXT parameter is sent at 20 WPM in international morse code at the times described for the HID command. If text is not present in the IDTEXT parameter, no code will be sent. The feature will not send correct code if the on-board NRZ-NRZI converter is bypassed.

The 1.1.9 TNC-2 executable is © 1994 InfoMotion, Inc. All rights reserved.

TNC-2 firmware is provided "as-is" and the user assumes the entire risk of utilizing the firmware. TNC-2 firmware is not intended, nor is it provided for, any purpose, including navigation, where failure of the firmware, or hardware, or both, might cause bodily injury or loss of property.

## Accessing TAPR via the Internet

There are several ways TAPR can be reached via the Internet.

### Information Server

The Automated Information Server that TAPR provides allows anyone to request information on TAPR, products, newsletters, and lots of other files. To find out more about this service, send an e-mail message to [listserv@tapr.org](mailto:listserv@tapr.org) with the subject line "Request" and one or more of the following text lines in the body of the message:

- help (for a brief set of instructions)
- index -all (for a list of all files by topic area)
- list (for a list of TAPR Mail Groups)
- get tapr taprinfo.txt (for info on TAPR)

### Internet E-Mail

TAPR can be reached by sending mail addressed to [tapr@tapr.org](mailto:tapr@tapr.org)

### World Wide Web

<http://bb.iu.net/infomotion/taprhome.html>

### FTP

The TAPR Software Library is available at 'ftp.hereford.ampr.org' in the directory pub/hamradio/tapr. Login in as 'anonymous', with a password of 'your\_account@internet\_address'.

## FCC Denies Reconsideration of Message Forwarding Rules

[Release from the FCC]

The Commission has denied the petition of Phil Karn asking for reconsideration of its decision concerning message forwarding systems in the Amateur Service. [Phil's petition was printed in PSR #55] Karn sought reconsideration of the Commission's decision that requires the licensee of the forwarding station to either authenticate the identity of the station from which it accepts communications on behalf of the system, or accept accountability for the content of the message.

On March 30, 1994, the FCC adopted an Order which provided that in contemporary message forwarding systems, the control operators of intermediate forwarding stations, other than the first forwarding station, would not be held accountable when their stations retransmitted improper communications inadvertently. The purpose of the Order was to relax the Amateur service rules to enable these systems to operate at high speed while retaining the minimum safeguards necessary to prevent misuse.

Denying reconsideration, the Commission said the Order did not address, nor was it intended to address,

w h a t accommodations should be made for message forwarding systems that may be developed in the future. This issue appeared to be the main concern of Karn's request for reconsideration. The Commission said that if the present accommodation becomes unworkable in a system using a different architecture, the managers of that system can request necessary rule changes at the appropriate time.

## Spread Spectrum STA Renewed

Dewayne Hendricks, WA8DZP

The STA that allows unrestricted use of spread spectrum emissions from 6 meters and up in the Amateur bands has just been renewed by the FCC. This STA was originally granted three years ago to Robert Buaas K6KGS, and has been renewed each year. Interested Amateurs may participate and operate under this STA by contacting Robert and getting his approval. This year's renewal is significant in that it has no expiration date. The text of the STA follows below:

Dear Mr. Buaas:

This is in response to your request date April 30, 1994, for extension of the special temporary authority (STA) and waiver of the Commission's Rules that you were granted on May 26, 1993. That STA and waiver permitted certain amateur stations to conduct experiments involving Code Division Multiple Access (CDMA) spread spectrum (SS) emissions.

Your request was presented to the Interagency Radio Advisory Committee, which expressed no objection to an extension. Accordingly, the STA and waivers granted May 26, 1993, are extended until completion of your data communications experiments. All other conditions of the May 26, 1993, authorization will remain in effect.

Sincerely,

Robert H. McNamara Acting Chief, Private Radio Division

Also be advised that the ARRL is very close to submitting a petition for rulemaking to the FCC regarding changes to Part 97 to allow less restrictive use of spread spectrum in the Amateur service.

# INTRODUCING THE 9600 BAUD PACKET LEADER

This all new 9600 Baud Azden Digital Radio is plug and play ready, from the front panel. High speed pin diode TX/RX switching and direct crystal modulation deliver ultra-fast TXDelay times. Wide RF input range and wideband IF offer full capability down to 430 MHz.

**BUILT TO MIL-STD-810 2 YEAR WARRANTY**

### GENERAL SPECIFICATIONS

**Frequency Range** (TX & RX) 430-450 Mhz  
**Display** Backlit amber LCD  
**Memories** 20 in two banks  
**PL Encode** 38 built-in tones  
**Power** +13.8 V @ 9 Amps  
**Temperature** -10 to +60 degrees C  
**TX/RX Switching** Solid State  
**Dimensions** 2"Hx5.5"Wx7.25"D  
 500mm H, 140mm W, 182mm D

### RECEIVER

**Receiving system** Double conversion Superheterodyne  
**Intermediate frequency** 1st-45 Mhz, 2nd-455 KHz (20KHz BW)  
**Sensitivity** <0.19 µV for 12 dB SINAD  
**Adjacent channel selectivity** >70dB  
**(30 KHz channel separation)**  
**Intermodulation** >60dB

### TRANSMITTER

**Output Power** 35/10 watts (Hi/Lo)  
**Modulation System** Voice-Variable reactance FM  
 Data-Crystal direct FM  
**Deviation** ± 5 KHz  
**Spurious radiation** >60dB



**THE PCS-96000**

**TO PLACE ORDERS  
 CALL 1-800-643-7655**



147 New Hyde Park Rd., Franklin Sq., NY 11010  
 (516)328-7501 FAX (516) 328-7506

## **NPRM: Allocation of Spectrum Below 5 GHz Transferred from Federal Government Use**

*[Edited from a release by the FCC]*

### **Introduction**

By this action, we propose allocations for 50 megahertz of spectrum that was identified by the Department of Commerce for transfer from Federal Government to private sector use. The spectrum we are considering is at the bands 2390-2400 MHz, 2402-2417 MHz, and 4660-4685 MHz. We believe that the allocations proposed herein will benefit the public by providing for the introduction of new services and the enhancement of existing services. These new and enhanced services will create new jobs, foster economic growth, and improve access to communications by industry and the American public.

### **Background**

On August 10, 1993, the Omnibus Budget Reconciliation Act of 1993 (Reconciliation Act) was signed into law. The Reconciliation Act required that the Secretary of Commerce identify 200 megahertz of spectrum currently allocated for use by Federal Government agencies, for transfer to the FCC for use by the private sector. All of the 200 megahertz of spectrum recommended for reallocation must be located below 5 gigahertz, with at least 100 megahertz of this being below 3 gigahertz. The Reconciliation Act also required the Secretary of Commerce to issue within six months of its enactment a report making a preliminary identification of reallocatable bands of frequencies and to issue within 18 months a final report recommending the spectrum for reallocation. In its report making a preliminary identification of spectrum, the Department of Commerce was required to identify at least 50 megahertz of spectrum for immediate reallocation. The remaining spectrum is to be made available over a ten-year period.

The frequency bands identified for reallocation in the Preliminary Report are listed in Appendix A. Three of these frequency bands, 2390-2400 MHz, 2402-2417 MHz, and 4660-4685 MHz, were identified for immediate reallocation. The Reconciliation Act also requires that the Commission allocate, and propose regulations to assign, the 50 megahertz of spectrum that is immediately available no later than 18 months after its enactment.

Accordingly, on May 4, 1994, we released a Notice of Inquiry (NOI) in this proceeding seeking information on potential applications for the 50 megahertz of spectrum that is being transferred

immediately from Federal Government to private sector use. We stated in the NOI that spectrum reallocated for private sector use has the potential to provide for the continued growth and development of advanced communications and technologies, thereby creating new high technology jobs and economic growth. Although the spectrum considered in this proceeding has some characteristics that will affect its future use by non-Government applications, we believe that all of the spectrum can be used to promote advanced technologies and provide economic growth. In response to our NOI, we received 77 comments and 17 reply comments.

Internationally, 2390-2400 MHz is allocated in Region 210 on a primary basis to the fixed, mobile, and radiolocation services, and on a secondary basis to the Amateur service. Domestically, this band is currently allocated on a secondary basis to the Amateur service.

The 2402-2417 MHz band is allocated internationally in Region 2 on a primary basis to the fixed, mobile, and radiolocation services, and on a secondary basis to the Amateur service. Domestically, the band is currently allocated on a secondary basis to the Amateur service. The 2402-2417 MHz band lies within the 2400-2500 MHz band that is available for use by industrial, scientific, and medical (ISM) applications. Radio services operating within this band must accept harmful interference that may be caused by ISM devices, which include a large number of microwave ovens commonly used in households. In addition, the 2400-2483.5 MHz band is available domestically for use by equipment authorized under Part 15 of the Rules.

Internationally, 4660-4685 MHz is allocated in Region 2 on a primary basis for fixed, fixed-satellite, and mobile services. This band is allocated domestically on a primary basis for non-government fixed-satellite service space-to-Earth links, with use limited to international inter-continental systems. However, there is currently no non-Government use of this band. An agreement with Canada requires that certain United States Government terrestrial line of sight and troposcatter systems be coordinated with Canada. This agreement also permits use of this band by airborne or other mobile stations but requires that such stations protect Canadian systems.

### **Discussion**

We are now considering allocating the spectrum at 2390-2400 MHz, 2402-2417 MHz and 4660-4685 MHz for new or developing services, or to provide spectrum to reaccommodate existing services. In response to our NOI initiating this proceeding we

received a number of competing and generally mutually exclusive proposals and requests, many of which might benefit the public. Our principal objective in making this spectrum allocation decision is to ensure that the spectrum is put to its best and most valued use and that the greatest benefit to the public is attained. We believe that the way to achieve this goal is to adopt a broad and general allocation. Such an approach would allow for flexible use of these bands so that licensees would be able to offer a wide range of services employing varying technologies. This approach is similar to one taken in previously where we redesignated spectrum in the 2 GHz range for emerging technologies. In that proceeding, we allocated 220 megahertz of spectrum to Fixed and Mobile services and identified it for use by emerging technologies. Later, we provided for the personal communications services (PCS) to use 140 megahertz of this spectrum. The remainder is available for future use.

We therefore request comment on an allocation approach that would designate the 2390-2400 MHz, 2402-2417 MHz and 4660-4685 MHz bands for general Fixed and Mobile services, rather than specify these frequency bands for particular uses. In this context, we believe such a flexible allocation that relies substantially on market forces may be appropriate. We also believe that under such an approach most of the services to be provided in this spectrum would likely meet the statutory criteria for auctions. Therefore, we are proposing to make licenses for this spectrum available through competitive bidding, to the extent possible and practicable. We also believe it is important to provide for a market structure that provides for competition in the provision of new services. A competitive market structure would promote economical prices for users and provide operators with incentives to develop and introduce innovative service features and technologies. One approach for developing a competitive market structure would be to divide the spectrum into channel blocks of one to two megahertz. Licensees would be given exclusive use of these channels within a specified geographic area. We request comment on this approach and the appropriate amount of spectrum to specify for a channel block and the extent of the geographic areas to which channel blocks would be licensed.

While we believe that the above plan for allocation to Fixed and Mobile services would ensure that the spectrum is used for services that are most highly valued by the public, we also recognize that such an approach may be difficult to implement given certain factors that are unique to these bands. For example, there are incumbent Amateur users in the 2390-2400

MHz and 2402-2417 MHz bands and the 2402-2417 MHz band is affected by emissions from ISM devices, including millions of household microwave ovens. In addition, a growing number of unlicensed Part 15 devices are also operating in this band. Accordingly, we believe it is appropriate also to solicit comment on identifying specific communications services as an alternative to relying only upon the general allocation. A number of such proposals were presented in the comments to the NOI.

In the 2390-2400 MHz band, In-Flight Phone Corporation (In-Flight) proposed an allocation for an aeronautical audio/visual service (AAVS). In-Flight's AAVS proposal has the potential to furnish commercial air travelers with real time video and audio information and entertainment services. According to In-Flight, the AAVS would be able to share spectrum with the Amateur and other services and, because it would be a ground-to-air service, would not present an interference problem for adjacent channel space research and radioastronomy operations.

Another alternative for the 2390-2400 MHz band is a proposal from Southwestern Bell that this band be paired with the 2300-2310 MHz band and be used for wireless local loop service. As described by Southwestern Bell, a wireless local loop service would enable a Local Exchange Carrier (LEC) to provide telephone service to the home via radio links rather than through a copper or fiber cable to each home. According to Southwestern Bell, the benefits of a wireless local loop service include reduced costs in providing telephone service to new customers, reduced telephone service maintenance costs, and rapid deployment of telephone service to new customers. Southwestern Bell further states that because of the high density of use in any particular area, a wireless local loop service would not be compatible with Amateur use of the spectrum.

We observe that this spectrum also could be used to provide unlicensed PCS or Multipoint Distribution Service (MDS). One possibility would be to provide unlicensed PCS services in either or both of the 2300-2310 MHz and 2390-2400 MHz bands. Alternatively, the 2300-2310 MHz and 2390-2400 MHz bands could be used to accommodate the MDS currently operating at 2150-2160 MHz, freeing that spectrum for unlicensed PCS.

There may also be benefit in using either the 2390-2400 MHz or the 2300-2310 MHz band for intelligent vehicle highway systems (IVHS). Motorola suggests that spectrum under consideration in this proceeding may be suitable for short range IVHS services.

In response to the NOI, we received several other suggestions for use of the 2390-2400 MHz band. These uses include interactive video in rural areas, low power communications, mobile-satellite service (MSS), and advanced private communications. We believe, however, that most of these uses are already adequately accommodated in other bands, could be accommodated under our general allocation proposal for these bands, or may not be suitable for the 2390-2400 MHz band. We request comments on our conclusions regarding these other alternatives. We invite comments on any other services that might be provided in this spectrum. Parties supporting alternative proposals for this band should address the compatibility of the proposed service with the Amateur and other services. Commenting parties should also provide a cost/benefit analysis for the service, along with specific information regarding operating parameters and any other relevant information. We also note that, while we have not specifically identified spectrum for advanced private communications as requested by the Coalition of Private Users of Emerging Multimedia Technologies (COPE), private users can receive service from commercial service providers and can compete in obtaining spectrum on the same basis as commercial providers. Additionally, we will continue to consider COPE's request for spectrum as we determine uses for additional spectrum being reallocated from Federal Government use under the Reconciliation Act.

In the 2402-2417 MHz band, the presence of ISM equipment, unlicensed devices (particularly spread spectrum devices) and other non-Government users present a particularly challenging environment in which to implement new radio services. Any equipment operating in this band must use transmission schemes that are extremely robust and versatile. Commenters to our NOI indicate that many of the companies currently manufacturing unlicensed Part 15 equipment for the 902-928 MHz band have begun to develop or modify this equipment for use at 2400-2483.5 MHz and several firms are selling devices for use in this band. We also note that Part 15 use is consistent with a number of suggestions for use of this spectrum, such as in-building voice and data systems, and small area communications. All of these uses can be accommodated under Part 15 of our rules. In light of this we request comment on retaining future use of this band by Part 15 equipment. Possibilities include eliminating this band from Part 15 use in order to avoid any potential conflicts with future licensed services, maintaining Part 15 use of this band and also implementing licensed services, or maintaining Part 15 use of this band while limiting licensed use of the band.

We request further comment on other suggestions received for use of the 2402-2417 MHz band, including providing licensed services in this band that are subject to technical rules that are similar to the rules for unlicensed Part 15 devices, or use of the band for MSS. MSS providers appear pessimistic regarding the utility 2402-2417 MHz for MSS. However, Loral/Qualcomm states that it is continuing to evaluate the possibility of providing MSS in this band.

Both the 2390-2400 MHz and 2402-2417 MHz bands are currently available for secondary use by the Amateur service. The Reconciliation Act directed the Department of Commerce to seek to avoid excessive disruption of the Amateur service and to determine the extent to which, in general, commercial users could share the frequency with Amateur radio licensees. The Department identified spectrum for transfer in light of this directive, and concluded that these two bands could be made available for commercial use without severely affecting the Amateur service. However, in their comments, the Amateur service community argues that the Department failed to meet the criteria of the Reconciliation Act. We recognize the importance of the Amateur service and, in making our allocation decisions, we will take into account existing use of the spectrum by the Amateur service. We therefore solicit information on several options. One approach for accommodating Amateur service use of these bands is to maintain a secondary allocation for the Amateur service in all or part of this spectrum. Another approach is to make the Amateur service the primary user in a portion of this spectrum while either maintaining a secondary allocation in the remaining portions of the bands or eliminating the other portions from the Amateur service. We also solicit information on the degree of disruption to the Amateur service that would result if all or part of this spectrum was removed from the Amateur service. We request comment on these options, including the ability of various radio services to share spectrum with the Amateur service.

## Appendix A

### NTIA Preliminary Spectrum Reallocation Plan

<u>Band</u>	<u>Status</u>	<u>Schedule</u>
1390-1400 MHz	Exclusive	January 1999
1427-1432 MHz	Exclusive	January 1999*
1670-1675 MHz	Mixed	January 1999
1710-1755 MHz	Mixed	January 2004
2300-2310 MHz	Exclusive	January 1996
2390-2400 MHz	Exclusive	Immediate
2402-2417 MHz	Exclusive	Immediate
3650-3700 MHz	Mixed	January 1999
4635-4660 MHz	Exclusive	January 1997*
4660-4685 MHz	Exclusive	Immediate

\* Protection for a limited number of facilities would be required for an additional period of time.

## TAPR 1995 Annual Meeting

Annual meeting preparations continue and pre-registration has been steady. If you think you will be attending, you can save some money and help TAPR set reservation levels by pre-registering. The meeting is set for March 3rd, 4th, and 5th, 1995, in St. Louis, MO. Information will be mailed to all pre-registered folks before the meeting. If you are staying at the hotel, it is **HIGHLY** recommended that you make your room reservations as soon as possible. We have a block of rooms on reserve, but this will be released the first of February. When making reservations, indicate that you are attending the TAPR meeting. The annual meeting hotel is Henry VIII, (800) 325-1588, in MO call (800) 392-1660. It is located on Lindbergh (US 67) one-half mile north of I-70 and one mile south of I-270.

Meeting registration and the TAPR hospitality room will open in the Henry VIII hotel starting at 12 noon on Friday in the London room. This room is located directly above the hotel lobby. On Saturday, registration will move to the college.

There have been a lot of questions concerning the Friday DSP symposium. First, the cost of the symposium has been dropped. Anyone who has pre-registered and already paid for the Friday symposium will not be charged. The reason for this change is that there are now no

associated costs with the symposium. In addition, the dinner will no longer be offered, since it is now planned to hold the symposium from 3pm to 6:30pm on Friday. This will allow everyone attending the symposium to attend the regular informal dinner on Friday. The purpose of the symposium is to bring DSP programmers together to discuss tools and programming techniques. This is for those currently working with DSP technology. Location for the symposium will be provided with the pre-registration packet and at the hospitality suite on Friday. Currently, it is planned for the hotel, but this might change to the college depending on available space. Jon Bloom, KE3Z, will be hosting the DSP symposium.

Friday evening around 6:30 to 7pm, TAPR will host its informal dinner. Location for this event is yet to be determined. Location will be available at time of registration. The hospitality room will open again after Friday's dinner to provide a place for late night discussions.

The annual meeting formally begins Saturday morning at 8:30am with presentations and papers, as well as discussion on

other projects of interest throughout the day. Registration will begin at 8:00 am. The location will be St. Louis Community College at Florissant Valley, 3400 Pershall Rd., along I-270, east of I-170, and west of West Florissant Ave. (see map) The TAPR meeting will be held in the Theater, which is on the north side of the campus. Parking is available to the west of the buildings. If you need to drop someone off or require handicap parking, a driveway runs directly in front of the theater.

For lunch on Saturday, we are working on providing lunch at a slight additional cost for those that do not want to venture off campus. The TAPR Annual Meeting Committee is meeting with the food services people at the end of January to finalize the cost of a lunch special. Lunch was not included in the original meeting price, because it was expected that the main food area of the college would be available for our use. However, late in December, the college has scheduled a major event which now occupies these areas and eliminates our ability to offer an open lunch. If you think you would be interested in lunch, you can contact the office and put your name on the lunch list. Money for lunch will be collected Saturday morning during registration.

It is expected that there will be four 90 minute sessions with long breaks between each session. Lunch is scheduled from 12noon till 1:30pm when the afternoon session begins. The last session of the day will be a breakout for two discussion topics. Currently HF digital

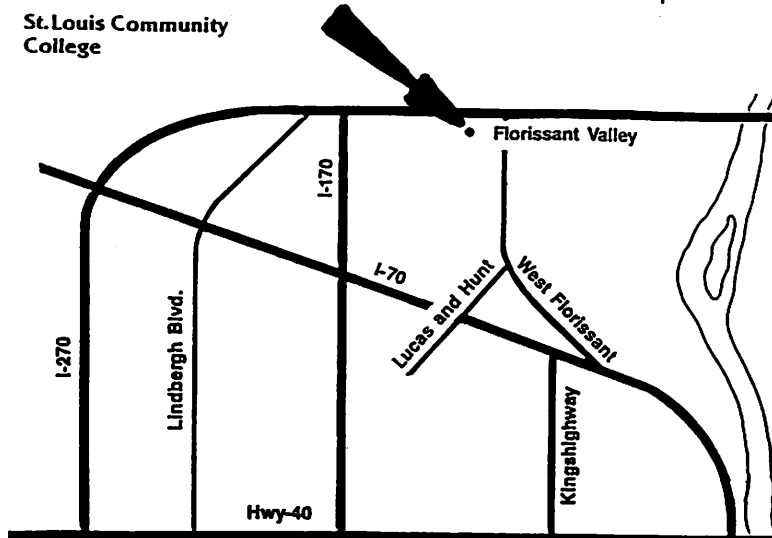



communications, hosted by Johan Forrer, KC7WW, is one of these. Some table space will be provided in the foyer of the theater for those wishing to setup demos or handout materials. Contact Mel Whitten, K0PFX, k0pfx@tapr.org, annual meeting chair for details.

After the last session at the college, current plans have the dinner back at the hotel, starting around 6:30pm. The dinner will include a speaker and prize drawing! After dinner, Special Interest Groups will meet and discuss issues. On Sunday, two workshops will be held. One will focus on Error Correction Techniques, by Phil Karn, KA9Q, while the second will focus on higher level interests for the development of hardware/software for the TAPR/AMSAT DSP-93, by Bob Stricklin, N5BRG. There have been a number of requests to reschedule the Sunday symposiums as back to back sessions. The Error Correction Techniques will now run from 8:30am till 11:30am, with the DSP-93 session running from 12noon till 3pm. This will allow everyone to attend both sessions and give ample time to catch afternoon flights. The workshops are currently scheduled to be held at the college theater.

Transportation between the hotel and college, for those not having cars, will be made available. TAPR will be renting one 15 person van as a shuttle to run throughout the day and several St. Louis hams have volunteered the use of their vans during the morning and evening rushes. Full details on the van schedule and times of transportation will be sent with pre-registration information and be available during registration on Friday. If you think you need will require the use of transportation, please inform the office so we can estimate a count.

All indications show that this will be a well-attended annual meeting and we are hoping that the weather cooperates. See you in St. Louis!

### Proceedings Deadline

Authors are encouraged to submit written versions of papers for publication in the Proceedings. The Proceedings will be distributed to all registrants at the time of the Annual meeting, and will be available for purchase in limited quantities afterwards. Author guidelines are available from the TAPR office, and by anonymous ftp on Internet from /pub/TAPR at cirsl.cirs.org (file name is "guidelines"). You can also request the guidelines by e-mail from the Proceedings editor at kf7tp@kf7tp.stat.com. Deadline for receipt of camera-ready copy, in printed or electronic form is February 7th, 1995. Papers should be submitted in electronic form or by mail to the Proceedings editor at:

Keith Justice, KF7TP  
2652 E. Kael St.  
Mesa, AZ 85213  
Voice: 602-461-8687  
FAX: 602-461-0716

Internet: kf7tp@kf7tp.stat.com

### New Dayton HamVention Packet Event!

The 1995 "Packet BASH" sponsored by TAPR and the Miami Valley FM Association will be held on Friday, April 29th, in conjunction with the 1995 Dayton HamVention. The BASH will be at TJ's Restaurant, at the Dryden Road exit of I-75 just south of downtown Dayton (2462 Dryden Road, across from the Holiday Inn). We'll have a buffet dinner, a raffle for some neat prizes, a great program, and lots of fun. The cost will be approx. \$15 per person and there will be a cash bar. We hope that this will provide an opportunity for packet and digital radio enthusiasts to have a great night out while at the HamVention.

The schedule of events is still tentative, but will look something like this:

- 19:00 Dinner
- 19:45 Welcome
- 20:00 Keynote Address
- 20:30 Raffle
- 20:45 TAPR SIG Meetings
- 22:00 Birds-of-a-Feather breakout groups

For more information, send e-mail to packbash@ag9v.ampr.org or stop by the TAPR booth at Dayton for schedule and map.

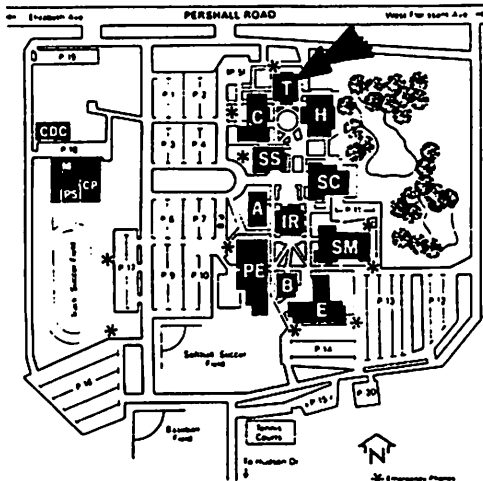

**Renew Your Membership!**

TAPR sends out renewal reminders quarterly, but to find out when your membership will expire, check your mailing label. Your membership is very important.

## TAPR Board of Directors Elections

Ballots were sent out at the end of December. All paid members in TAPR as of December 1st, 1994, should have received a ballot and return envelope. Deadline for balloting is February 11th, 1995. If you have not received a ballot by February 1st, call the office and request a ballot be sent. Three positions are open this year.

The following TAPR members have been nominated for election this year to the TAPR Board of Directors.

### John Ackermann - AG9V jra@ag9v.ampr.org

I've been a ham since 1974, and active in packet radio since 1986. My current interest is network building, and I've spent the last couple of years putting together a 19.2kB network in Ohio. We're now starting to play with spread spectrum systems and with 900 MHz point-to-point links. I also run a Linux system accessible via tcp/ip and am trying to provide some real applications to the local packet community. I'm currently the chairman of TAPR's NetSIG special interest group and e-mail list. In my spare time, I'm a lawyer with AT&T Global Information Solutions (formerly NCR Corp). I do software licensing and other computer-law related stuff.

What can I offer TAPR as a Board member? Well, to start with, I have a strong interest in advancing the state of the packet radio art. I have experience as an officer and board member of groups ranging from radio clubs to humane societies. Finally, although I won't (and can't) become TAPR's lawyer, my professional background may be of

use as TAPR explores new commercial opportunities.

### Robert J. Diersing - N5AHD n5ahd@unix1.cba.tau.edu

During the late 1960s one of my favorite pastimes was SWLing radio teletype traffic on the HF bands. Consequently, it is fair to say that my interest in digital communications via radio preceded my interest in Amateur radio.

I became interested in Amateur packet radio in late 1981 after having attended the first ARRL Computer Networking Conference. This led to the construction of two Vancouver TNCs, the first of which was tested by recording a connect frame and then playing it back into the modem, since there wasn't anyone local to connect with at the time.

I have been a member of TAPR for about the past six years, but I have been aware of the activities of the organization from its inception since I was a member of the TAPR Beta TNC test group. My primary activity in Amateur radio is monitoring and operating the digital communications satellites, primarily AO-16 and UO-22. Most recently, I have been serving as the AMSAT liaison on the Joint TAPR/AMSAT DSP-93 project.

Professionally, I am a faculty member in the Computer Information Systems Department at Texas A&M University-Kingsville. My primary teaching responsibilities include courses in telecommunications, programming, and microcomputer architecture. I also assist with equipment installation and maintenance for the university's Amateur radio club station (W5ZD) which includes a TexNet node.

### Barry McLarnon - VE3JF bm@hydra.carleton.ca

I was first licensed in 1962, and my interests during the early years centered on CW DX'ing and contests, with a bit of VHF and RTTY work on the side. Around 1981 or so, I became interested in the Amateur satellites, and dropped HF almost entirely to concentrate on them. My most exciting moments from that era were snagging KH6CC to make WAC on mode A, and making 2-way voice contacts with W5LFL and W0ORE in the space shuttle. In 1985, I joined the mad telephone scramble to get one of the first TAPR TNC-2 kits (and was successful), so I guess I have TAPR to blame for my current preoccupation with the digital side of Amateur radio. :-). In 1986 I built a homebrew PSK modem and was one of the first users of the FO-12 digital transponder, but since that time most of my ham activity has been more 'down to earth.'

I've been running a PBBS continuously since the beginning of 1987... first with the WA7MBL software, later supplemented with G8BPQ, and then switched to JNOS when it came along. 1987 was also the year that I became aware of this interesting new modem design from WA4DSY, and in '88 I made an expedition down to Dayton to pick up some kits from the GRAPES folks. After playing with the modems for awhile, I decided that we needed a bit-regenerating 56kb repeater if we were going to build a LAN around them, and with the help of a few cohorts, got it up and running in January 1990. We've never looked back!

It was also around 1987 that we became connected to the Internet at work, and the possibilities that I saw there in terms of exchanging

mail, news and other information have had a major influence on my approach to Amateur packet networking. The local network has been designed to facilitate and encourage the use of TCP/IP, and I put together a JNOS 'starter kit' which makes it quite easy to get up and running with NOS. As a consequence, the Ottawa area probably has one of the highest proportions of packet TCP/IP users in the world. I also set up one of the first packet-Internet gateways, which has proved to be a major stimulant for TCP/IP and local packet activity in general. Another big shot in the arm for us was Dave Perry's PI interface card design, which continues to keep our little group busy (too busy :-(-) cranking them out. In what's left of my spare time, I sysop several of the local nodes and the gateway, take care of a couple of Linux boxes, including the hydra.carleton.ca system which hosts the NOS-BBS mailing list and our Web server, serve as national IP address coordinator for Canada, write articles now and then, and spend lots of time answering questions by phone and email... many, many questions. In other words, I'm clearly nuts. :-) Fortunately, I have an understanding wife (Cathy, VE3JFA) who is also into packet herself.

Professionally, I'm a communications systems engineer who manages a small group doing research in digital radio broadcasting. Prior to that, I worked extensively in HF data transmission systems, and before that, in radio direction finding systems.

I sense that TAPR is making a comeback after a period in the doldrums, and I'd like to be a part of this resurgence. My priorities would be finding affordable ways to get to higher speeds (and I don't

mean 9600 bps!), developing guidelines for effective network design (with emphasis on Level 1), and increasing the availability of information through tools such as WWW... and, oh yes, cheering up Harold Price. :-)

**Jim Neely - WA5LHS**  
**wa5lhs@tapr.org**

I am currently on the TAPR board and active as its treasurer. I was first licensed in the early '60s and have been active continuously. During the Vietnam war, I ran phone patches on the MARS networks and got my first taste of digital communications with RTTY communications. During the '70s I was active in organizing the local VHF FM activities. My first contact with packet radio was in the mid '80s. (My PK-232 is serial number 1278.) I have been active in setting up the local area packet network. I have been the president of one or the other of the local Amateur radio clubs for the last seven years and lead the creation of a local scholarship fund for licensed Amateurs. I have also been active in Texas Packet Radio Society and TAPR for several years. I have served as Treasurer and a director of both organizations.

**Kits Update**

**1.2 Ghz radios**

As of the end of December, TAPR has only received four inquiries concerning the German 1.2 Ghz radio. If you are interested, be sure to contact the office. See issue #56, page 26 for details. Current interest indicates no further effort should be done by TAPR.

**TAPR TNC-95**

It would take a long article to describe the thought and effort that have gone into the design of the TNC-95 as described below. Some of the more important points that have been discussed over the past few months include the need to support:

- a low-cost data controller for internal use in the DSP-93.
- future TAPR kits that require data controllers (i.e. PCON, METCON-II, etc.)
- for those that want a standalone package.
- networkers who require a low-cost versatile multi-port network controller that can be used in a variety of situations, but will easily allow for porting of the existing software base. The concept of channel element or communications co-processor could be used in some situations.
- a replacement for the TNC-2 bare boards TAPR has been offering since 1991.
- a new OEM design that can be offered by TAPR.

The process of the design began in July 1994 when a survey was conducted with individuals who had purchased TNC-2 bare boards. This survey was the results of having to make a decision in regards to having more TNC-2 bare boards produced. The PCB house had doubled the price and we really wanted to know if we needed to go to the effort of doing more boards or discontinue the product. The result was interesting — 80% of the purchasers were only building the data controller section for networking and leaving the rest of the board unpopulated. This seemed to us as a waste of cost to produce a board that more than 50% was not being used by 80% of the people purchasing it. Also, at about the same time, the beta-dsp

group had determined that a TNC inside the DSP-93 was going to be required. The decision was made to discontinue the TNC-2 bare board and to start design of what is now called the TNC-95.

The TNC-95 is a design that attempts to address a wide variety of needs without requiring "payment" for unused features. The concept currently is that the TNC-95 will be available as a bare board, a core kit, and the additional options that might need to be added later for different functionality. The selection of parts for the unit, should make it easier to find if the builder does not wish to purchase a complete kit from TAPR. Parts procurement for the older TNC-2 bare board was difficult.

The core consists of a Z180 MPU, an 85C30 SCC, an EPROM and two SRAM. The EPROM and SRAM may be any size between 32k x 8 and 512k x 8. The core configuration provides two synchronous ports and two asynchronous ports with TTL level interface.

No modem is provided on-board. The 85C30 will support a variety of speeds to allow a variety of modems to be supported. Since modems are not standard from area to area, it did not make sense to provide modems on the board. In addition, having the modem as an external device promotes the modular approach that this kit strives for. Many times, the modem and radio are tuned to each other, so this can be a benefit to many. No other components are required to add a second modem channel, except the modem.

The TNC-95 is designed in such a manner as to allow it to be configured for either external use or internal (PC Plug-in) use. To get the functionality of an external controller, an external modem (for

desired speed) and a MAX232 chip to get RS-232 drive levels are added to the core configuration. If you want to use the card as a plug-in to the ISA bus, then instead of adding the MAX232, you add a kit of parts that provides the ISA bus interface. The card looks to the PC like a COM port. Provisions are made to allow I/O port addresses 268H, 278H, 2E8H, 2F8H, 368H, 378H, 3E8H and 3F8H with IRQs of 2, 3, 4, 5, 10, 11, 12, and 15. DMA operation is also supported. Power can be supplied from the ISA backplane or an external 12vdc supply.

The third option that may be added is a second 85C30. This will allow the addition of 2 more external modems. If high-speed ports are required, then one of the 85C30 ports can be used for that function.

With the above configurations, you can begin to see the potential of this unit. If you are running X1J, TheNET, ROSE, or TexNet, then no modifications will be required in hardware, since there is enough space for the larger size EPROMS, after code has been ported. In addition, one TNC-95 can replace four TNCs for many that are networking with TNCs. The concept of having the TNC-95 as a channel element for future networking is important. The TNC-95 fills a niche for the 1200-19.2K+ operations and allows other Amateur PC boards available to provide higher speed access. No high end limit can be set until the unit is actually finished and tested.

We have been in touch with the developers of code for the TNC-2 and will be contacting them when beta-test units are available for them to port code on. Hopefully we will have a wide range of code

available at the introduction of the product.

The TNC-95 will be in prototyping in January. Timeline after that will depend on how the prototype comes out. A small group of beta-testers has already been selected. The goal is to try to have PCBs available sometime by the middle of 1995. More information to follow in a later *PSR*.

### **TrakBox Firmware Update**

Jack Davis, WA4EJR  
TAPR TrakBox Manager

As most active TrakBox users must know by now, there is a bug in firmware versions 3.30a through 3.30h. The problem relates to the the clock settings — now that we are in the year 1995. New code is available from various sources for the benefit of those users who have programming capability. The code will be posted on KO-23 and KO-25 as soon as the birds are back in normal service. You can also find the code in DL5 of the HamNet forum on CompuServe. We expect it will become available in many more places after that as users spread the word.

Thanks to Sueo Asato, JA6FTL, for providing version 3.30i so quickly.

For the benefit of users not having programming capability, TAPR will provide new ROMS at a of cost \$12 + \$2 for U.S. Shipping/Handling.

If you received a TrakBox from TAPR after Nov 1, 1994, contact the office about the procedure to get your EPROM replaced.

## TUC-52

The TUC-52 project is moving along. The goal of this project is to create a simple low-cost microcomputer controller with lots of parallel I/O that can be interfaced to a personality I/O board to implement some particular solution of interest to ham radio techies. The controller is based on an 80c32 processor (8 bit).

At this point, the core processor board is in layout. We've had some problems getting a valid net list out of the schematic capture system, but that problem has been solved. The current problem is getting the 6 liters worth of components to fit in the 5 liter box. It looks like the typical ham radio solution of

simply applying more force will solve this problem.

We also have draft schematics of personality boards that, when combined with the TUC-52 core processor board, will create a printer controller system (PCON) and telemetry and control system (METCON-2). These schematics, and associated circuit descriptions, should be ready for comment around January, 1995. We are actively seeking input on other functions that may be of interest to the membership.

We are very fortunate to have someone on the team that's intimately familiar with the 8052 BASIC system. He has been able to modify the internals of the 8052 BASIC to provide for some of the

features of the METCON-1 system, all under interrupt control. These include an 8 channel frequency counter (0 to 65535 Hz possible), a 16 channel pulse counter (values can range from 0 to 65535), a 16 input channel state change flag register, and several other real-time features that should be of interest to people controlling external devices.

**Note:** Beta-test applications are being taken for testing of the TAPR TUC-52 project. Contact the office to get an application mailed, faxed, or e-mailed. A small group of testers will be selected from those submitted. Not all applications can be accepted. A reliable and low-cost Internet e-mail connection is a must.

Testers are required to sign a Volunteer's Agreement and must cover the cost of the Kits.

## DSP-93 Update on Sales for March

Deadline for the March batch of DSP-93 units was December 31st, 1994. We have filled 90 of the 150 orders as of December 18th, so additional slots will most likely be available as of this PSR printing.

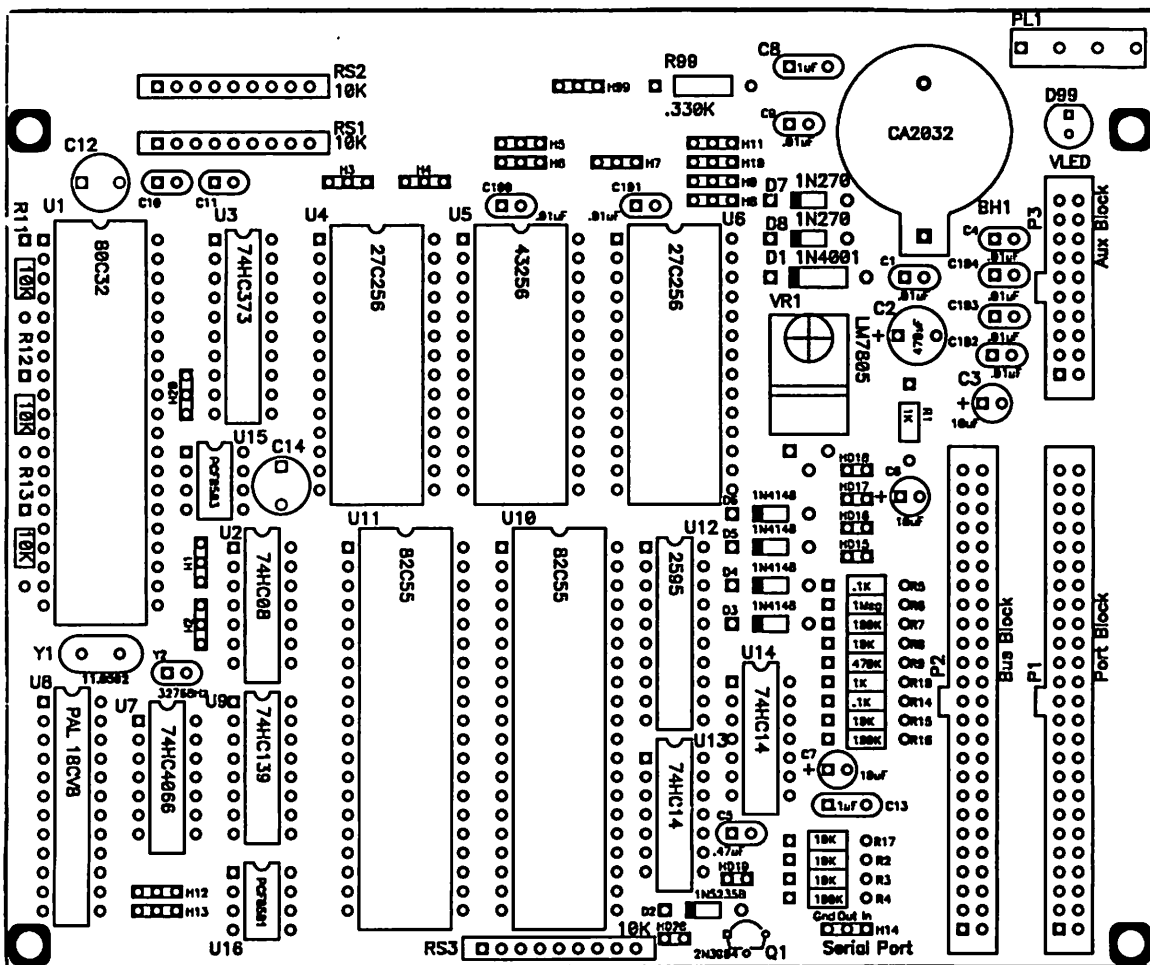

TUC-52 Board Layout (Actual Size)

Current as of 15 December 1994. Items with \*\* notation have been updated since the last listing in *PSR*.

**Rudak-U Fund Raiser**

RUDAK-U donations as of December total over \$2700. TAPR still needs to raise another \$3300 to reach the \$6000 pledged by TAPR. As of the AMSAT-NA meeting, RUDAK-U is now the only digital experiment being scheduled for launch on Phase 3D. RUDAK-U is going to offer some tremendous advantages for high-speed and long-distance communications, since it will be overhead for extended periods. Currently one regional packet group has donated \$250 and we are hoping to find other regional groups that will see the potential benefits of the proposed high-speed server and the possibilities of long-haul networking via the Phase 3D satellite. Contact the office if you can help with this project.

**TAPR Processes  
Shareware  
Registration for paKet**

TAPR has been appointed an official registration site for the paKet shareware software package by Tony Lonsdale, VK2DHU, author of paKet. To register a copy, please send \$20 (U.S.) to TAPR, along with your name, address and callsign. You will be sent your registration serial number by return mail. PaKet version 6.1 is available on disk from TAPR (disks 35 and 35A) for \$6.00 (including shipping in the U.S.). Registered users of a previous version can use their present registration serial numbers.

<u>Disk No.</u>	<u>Name</u>	<u>Version</u>	<u>Date</u>
1.	APLINK	Ver. 7.01	02-28-93
2.	AA4RE BBS	Ver. 2.12	03-31-92
3.	CBBS	Ver. 7.20	01-05-93
4.	EZPAC	Ver. 1.1	01-09-89
5.	MONAX		10-30-87
6.	Ham Comm	Ver. 3.08	03-08-91
7.	TNC-2 Manual and EPROMs	Ver. 1.18A	09-29-92
8.	Text conversion Utilities		
	R95	Ver. 4.0	01-25-92
	7PLUS	Ver. 2.02	06-27-92
	UUENCODE/UUDECODE	Ver. 5.21	01-26-93
9.	ROSERVER PRMBS	Ver. 1.73	05-08-92
10.	ROSE X.25 SWITCH	Ver. 3.3	04-17-93 **
11.	KA9Q NET	Ver. K34	01-14-94
12.	WXN Weather Svr.	Ver. 5.11	06-07-94
13.	TNC1 CODE & TNC2 Notes		03-28-90
14.	Deleted; now included on disk 13.		
15.	WA7MBL BBS	Ver. 5.14	02-11-90
16.	W0RLI BBS	Ver. 18.01	10-15-94 **
17.	YAPP	Ver. 2.0	12-18-86
18.	INTRO TO TCP/IP		09-09-87
19.	LAN-LINK	Ver. 2.32	06-05-94 **
20.	ARESDATA	Ver. 1.6	12-31-92
21/21A.	MSYS	Ver. 1.16/1.17	03-24-94 **
22.	G8BPQ NODE	Ver. 4.08	11-05-94 **
23.	UTILITIES		
	PKARC	Ver. 3.6	
	PKZIP	Ver. 2.04G	
	LHA	Ver. 2.11	
	ZOO	Ver. 2.10	
	UUENCODE/UUDECODE	Ver. 5.21	
24.	THS	Ver. 2.50	11-11-89
25.	VE4UB NTS	Ver. 091891	09-18-91
26.	NM1D DOSGATE	Ver. 1.14	11-29-89
27.	SV7AIZ BBS	Ver. 3.24	04-05-90
28.	TEXNET	Ver. 1.6	02-05-91
29.	Intro To Packet Radio, A Tutorial		05-07-93
30.	MICROSAT Ground-station Software		
	PB		04-30-92
	PG		02-25-92
	PFHADD		03-24-92
	PHS		12-21-90
31.	No Longer Available (see 38/38A)		
32.	PAMS-Personal AMTOR Mailbox	Ver. 2.09	08-14-93 **
33.	TNC-2 Z-80 Monitor	Ver. 2.00	09-02-91
34.	GIL (Graphics Interchange Lang.)	Ver. 1.03	03-30-91
35/35A.	PAKET	Ver. 6.1	08-15-94 **
36/36A.	F6FBB BBS	Ver. 5.15	03-06-93
37.	TPK	Ver. 1.82	10-24-94 **
38.	JNOS (Executables, docs.)	Ver. 1.10H	12-01-94 **
39/39A.	JNOS (Source Code for 38)	Ver. 1.10H	12-01-94 **
40.	SP Packet	Ver. 6.01E	02-06-92
41.	TAPR Deviation Meter Source and Tools		10-01-93
42.	PCTOR/PC-PACTOR	Ver. 3.02A	08-10-93
43.	METCON ROM Code	Ver. 1.07	01-17-93

Orders for any of the above disks should be sent to the TAPR office. New submissions or updates should be sent to the TAPR Software Librarian: Bob Nielsen, W6SWE, nielsen@primenet.com



**Tucson Amateur Packet Radio**  
 8987-309 E. Tanque Verde Rd #337  
 Tucson, Arizona • 85749-9399  
 Office: (817) 383-0000 • Fax: (817) 566-2544  
 Non-Profit Research and Development Corporation

# Order Form

**January 1995**

All prices subject to change without notice and are payable in U.S. funds. Members receive 10% off on Kits and Publications.  
 Please allow six to eight weeks for your order to be shipped. For specific information on kits, see Product Description flyer.

Office Hours: Tue-Fri 9am-12pm, 3pm-5pm CST

## Kits / Firmware / Publications

Qty	Item	Unit Price	Total Price	Kit Code	Information
_____	DSP-93 w/ wall transformer (US) .....	\$ 430.00	_____	16	check with office on ship date, <u>no discount</u>
_____	DSP-93 w/o wall transformer .....	\$ 420.00	_____	16	for international orders only, <u>no discount</u>
_____	AN-93 HF Modem .....	\$ 90.00	_____	3	limited kits available.
_____	TAPR 9600 bps Modem .....	\$ 80.00	_____	6	
_____	Bit Regenerator .....	\$ 10.00	_____	1	used for regenerative repeater operation
_____	Clock Option .....	\$ 5.00	_____	1	used for regenerative repeater operation
_____	PK-232 Modem Disconnect .....	\$ 20.00	_____	2	simplifies connection of external modems
_____	PK232MBX Installation Kit .....	\$ 20.00	_____	2	for installation of 9600 modem in PK-232MBX
_____	XR2211 DCD Mod. ....	\$ 20.00	_____	2	
_____	State Machine DCD Mod. ....	\$ 20.00	_____	2	
_____	State Machine DCD w/Int Clock .....	\$ 25.00	_____	2	For KPC2 or other TNC w/o 16X or 32X int clock
_____	Trak-Box .....	\$ 195.00	_____	6	<u>member discount \$10.</u> limited kits available.
_____	METCON-1 Telemetry/Control .....	\$ 85.00	_____	6	includes 8 input, 4 outputs. limited kits available.
_____	4 additional output ports .....	\$ 15.00	_____	1	
_____	Voltage-to-Frequency module .....	\$ 30.00	_____	3	
_____	Temperature-to-Freq module .....	\$ 40.00	_____	3	
_____	A-D Converter .....	\$ 45.00	_____	3	
_____	Elapsed Time Pulsar .....	\$ 35.00	_____	3	
_____	Deviation Meter .....	\$ 95.00	_____	5	limited kits available
_____	32K RAM w/ TNC2 update docs .....	\$ 20.00	_____	2	
_____	TNC-2 1.1.9 w/KISS EPROM .....	\$ 15.00	_____	2	includes 1.1.9 Commands booklet (below)
_____	1.1.9 Commands Booklet (only) .....	\$ 8.00	_____	2	full TNC-2 command set for 1.1.9
_____	TNC-2 WA8DED EPROM .....	\$ 12.00	_____	2	8 connect version for ARES/Data standard
_____	TNC-1 WA8DED EPROM .....	\$ 12.00	_____	2	
_____	TNC-2 KISS EPROM .....	\$ 12.00	_____	2	
_____	TNC-1 KISS EPROM .....	\$ 12.00	_____	2	
_____	PK-87 WA8DED EPROM .....	\$ 12.00	_____	2	
_____	Packet Radio: What? Why? How? .....	\$ 9.00	_____	2	130 pages. TAPR's Packet Radio book.
_____	TAPR's 94 Annual Proceedings .....	\$ 7.00	_____	2	Papers from the Annual Meeting (Tucson)
_____	TAPR's 95 Annual Proceedings .....	\$ 7.00	_____	2	Papers from the Annual Meeting (St Louis)
_____	PSR Set Vol 1 (#1 - #17 '82 - '85) .....	\$ 20.00	_____	5	
_____	PSR Set Vol 2 (#18 - #36 '86 - '89) .....	\$ 20.00	_____	7	
_____	PSR Set Vol 3 (#37 - #52 '90 - '93) .....	\$ 20.00	_____	7	
_____	NOSIntro, Intro to KA9Q NOS .....	\$ 23.00	_____	5	Ian Wade, G3NRW, TCP/IP over Packet Radio
_____	ARRL CNC Proceedings 1st - 11th .....	\$ call	_____	.	Individual Proceedings, call for prices
_____	Entire Set ARRL CNC 1st - 11th .....	\$ 80.00	_____	36	9 Proceedings from 1981 to 1993
_____	TAPR Badge .....	\$ 10.00	_____	0	include Name and Call for badge
_____	3 1/2" Disk from TAPR Library .....	\$ 3.00	_____	0	\$3 per disk. See TAPR Software Library List

Sub-Total Kits/Firmware/Publications/Disks: \_\_\_\_\_

:Added Total of Kit Codes \_\_\_\_\_

Members 10% Discount (Kits & Publications): \_\_\_\_\_  
 (Except were noted)

(Example: 9600modem w/ BitRegen: 6 + 1 = 7)

:Member # (Place New, if joining)

**Total Sales** (Sub-Total minus Discount) \_\_\_\_\_

Texas Residents add 7.75% tax

Membership (New or Renewal)

For Total Kit Codes between:

1-3	4-7	8-15	16-27	28-55
Add \$2	Add \$3 <sup>50</sup>	Add \$4	Add \$5	Add \$6

Kit Codes above 55 or INTERNATIONAL orders  
 Please call TAPR for Shipping & Handling Amount

**TOTAL Order Amount** \_\_\_\_\_

Credit Card # \_\_\_\_\_  
 (Visa/Mastercard Only)

Expires: \_\_\_\_\_ Signature: \_\_\_\_\_

Name: \_\_\_\_\_ Callsign: \_\_\_\_\_ City, State: \_\_\_\_\_

Address: \_\_\_\_\_ Zip, Country: \_\_\_\_\_



# TAPR 1995 Annual Meeting

March 3, 4, & 5 • St. Louis, Mo.

## Registration Form

Contact the TAPR office by Phone, Fax, or e-mail (Internet: [tapr@tapr.org](mailto:tapr@tapr.org)) to pre-register or for additional meeting information. MasterCard and VISA accepted.

### Annual Meeting

	(without dinner)	(with dinner)	
• Pre-Registration (before Feb 17th)	\$15.00 <sup>†</sup>	\$25.00 <sup>††</sup>	_____
• Late Registration or at door	\$20.00 <sup>†</sup>	\$30.00 <sup>††</sup>	_____

† — Annual Meeting Registration includes:

TAPR 1995 Proceedings

Saturday Sessions and SIG meetings

Lunch is not included. Check during registration about on campus lunch special.

†† — TAPR Dinner Saturday evening (limited space). Prize Drawing. Speaker (TBA)

### Workshops & Symposium

#### DSP Developers Symposium, Friday

3pm-6:30pm. Location TBD. Conducted by Jon Bloom, KE3Z

Dinner is not included in current session.

FREE

#### Error Correction Techniques, Half-Day Workshop, Sunday

8:30am - 11:30am. College Theater. Conducted by: Phil Karn, KA9Q

• Pre-Registration (before Feb 17th)

\$10.00

• Late Registration or at door

\$15.00

#### TAPR/AMSAT DSP -93, Half-Day Workshop, Sunday

12noon - 3:00pm. College Theater. Conducted by: Bob Stricklin, N5BRG

• Pre-Registration (before Feb 17th)

\$10.00

• Late Registration or at door

\$15.00

**TOTAL Registration** \_\_\_\_\_

Credit Card # \_\_\_\_\_ Expires: \_\_\_\_\_ Signature: \_\_\_\_\_  
(Visa/Mastercard Only)

Name: \_\_\_\_\_ Callsign: \_\_\_\_\_ City, State: \_\_\_\_\_

Address: \_\_\_\_\_ Zip, Country: \_\_\_\_\_

Home Phone: \_\_\_\_\_ Work Phone: \_\_\_\_\_ Fax: \_\_\_\_\_

Tucson Amateur Packet Radio • 8987-309 E Tanque Verde Rd #337 • Tucson, Az • 85732  
Office (817) 383-0000 • Fax (817) 566-2544

TAPR is a Non-Profit Research and Development Corporation