

# POWERS OF 10

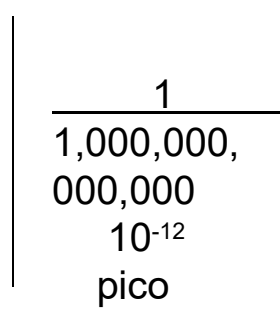
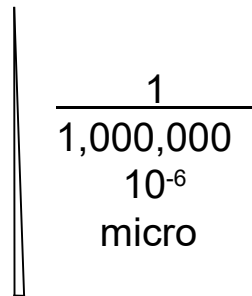
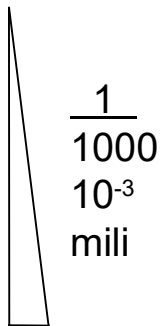
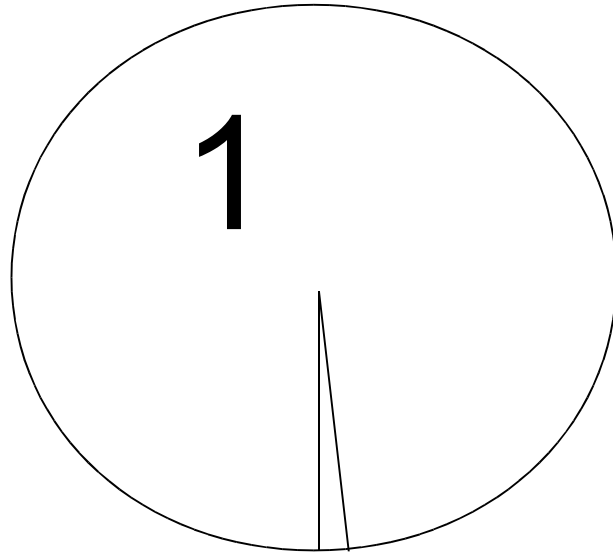

# POWERS OF TEN

**22,000 nF = 22  $\mu$ F**

**3.525 MHz = 3525 kHz**

**3,725 kHz = 3,725,000 Hz**

**3000 mA = 3 Amps**

**3500 mV = 3.5 Volts**

**1000 Hz = 1kHz**

**1.265 GHz = 1265 MHz**

**1,000,000 pF = 1 Microfarad**

**400 Centimeter = 4 Meters**

**500,000 Microfarads = .5 Farads**

**T5B01**

**How many milliamperes is 1.5 amperes?**

- A. 15 milliamperes
- B. 150 milliamperes
- C. 1500 milliamperes
- D. 15,000 milliamperes

**T5B02**

**Which is equal to 1,500,000 hertz?**

- A. 1500 kHz
- B. 1500 MHz
- C. 15 GHz
- D. 150 kHz

**T5B03**

**Which is equal to one kilovolt?**

- A. One one-thousandth of a volt
- B. One hundred volts
- C. One thousand volts
- D. One million volts

**T5B04**

**Which is equal to one microvolt?**

- A. One one-millionth of a volt
- B. One million volts
- C. One thousand kilovolts
- D. One one-thousandth of a volt

**T5B05**

**Which is equal to 500 milliwatts?**

- A. 0.02 watts
- B. 0.5 watts
- C. 5 watts
- D. 50 watts

**T5B06**

**Which is equal to 3000 milliamperes?**

- A. 0.003 amperes
- B. 0.3 amperes
- C. 3,000,000 amperes
- D. 3 amperes

**T5B07**

**Which is equal to 3.525 MHz?**

- A. 0.003525 kHz
- B. 35.25 kHz
- C. 3525 kHz
- D. 3,525,000 kHz

**T5B08**

**Which is equal to 1,000,000 picofarads?**

- A. 0.001 microfarads
- B. 1 microfarad
- C. 1000 microfarads
- D. 1,000,000,000 microfarads

**T5B12**

**Which is equal to 28400 kHz?**

- A. 28.400 MHz
- B. 2.800 MHz
- C. 284.00 MHz
- D. 28.400 kHz

**T5B13**

**Which is equal to 2425 MHz?**

- A. 0.002425 GHz
- B. 24.25 GHz
- C. 2.425 GHz
- D. 2425 GHz

## **Names in Electronics**

- Alessandro Volta > Volt**
  - Andre-Marie Ampere > Amp**
  - George Simon > Ohm**
  - Michael Faraday > Farad**
  - Joseph Henry > Henry**
  - Heinrich Rudolf Hertz > Hertz**
  - Henry got H so Hertz got Hz**
- 

**T5C07**

**What is the abbreviation for megahertz?**

- A. mHz
- B. mhZ
- C. Mhz
- D. MHz

**T5C13**

**What is the abbreviation for kilohertz?**

- A. KHZ
- B. khz
- C. khZ
- D. kHz

# BASIC UNITS

## Voltage or electromotive force

Pressure or force

Volt

Symbol = E

## Current

Electron flow

Amp

Symbol = I

## Resistance

Impedes current flow

Ohm

Symbol = R

DC and RF

1 volt at 1 amp = 1 ohm

## Power

How fast electrical energy is used

Watt

Symbol = P

### T5A05

What is the electrical term for the force that causes electron flow?

- A. Voltage
- B. Ampere-hours
- C. Capacitance
- D. Inductance

### T5A03

What is the name for the flow of electrons in an electric circuit?

- A. Voltage
- B. Resistance
- C. Capacitance
- D. Current

### T5A01

Electrical current is measured in which of the following units?

- A. Volts
- B. Watts
- C. Ohms
- D. Amperes

### T5A04

What are the units of electrical resistance?

- A. Siemens
- B. Mhos
- C. Ohms
- D. Coulombs

**T5A11**

**What type of current flow is opposed by resistance?**

- A. Direct current
- B. Alternating current
- C. RF current
- D. All these choices are correct

**T5A02**

**Electrical power is measured in which of the following units?**

- A. Volts
- B. Watts
- C. Ohms
- D. Amperes

**T5A10**

**Which term describes the rate at which electrical energy is used?**

- A. Resistance
- B. Current
- C. Power
- D. Voltage

## BASIC UNITS 2

### Frequency

The rate that AC changes

Hertz or cycles per second

### Audio

Standard human hearing

20 Hertz to 20,000 Hertz

### Radio frequency

Above 20 kHz

### Wavelength

Length of one cycle

Wavelength in Meters =  $300 /$   
frequency in MHz

**T5A12**

**What describes the number of times per second that an alternating current makes a complete cycle?**

- A. Pulse rate
- B. Speed
- C. Wavelength
- D. Frequency

**T5A06**

**What is the unit of frequency?**

- A. Hertz
- B. Henry
- C. Farad
- D. Tesla

## **Radio Frequency (RF) Names**

**VLF Very Low Frequency**

- 3 To 30 kHz

**LF Low Frequency**

- 30 To 300 kHz

**MF Medium Frequency**

- 300 To 3000 kHz

**HF High Frequency**

- 3 To 30 MHz

**VHF Very High Frequency**

- 30 To 300 MHz

**UHF Ultra High Frequency**

- 300 To 3000 MHz

**EHF Extremely High Frequency**

- 3 To 30 GHz

- Microwave

**T5C06**

**What does the abbreviation “RF” refer to?**

- A. Radio frequency signals of all types
- B. The resonant frequency of a tuned circuit
- C. The real frequency transmitted as opposed to the apparent frequency
- D. Reflective force in antenna transmission lines

**T3B10**

**What frequency range is referred to as HF?**

- A. 300 to 3000 MHz
- B. 30 to 300 MHz
- C. 3 to 30 MHz
- D. 300 to 3000 kHz

**T3B08**

**What frequency range is referred to as VHF?**

- A. 30 to 300 kHz
- B. 30 to 300 MHz
- C. 300 to 3000 kHz
- D. 300 to 3000 MHz

**T3B09**

**What frequency range is referred to as UHF?**

- A. 30 to 300 kHz
- B. 30 to 300 MHz
- C. 300 to 3000 kHz
- D. 300 to 3000 MHz

## CONDUCTOR INSULATORS

- **Conductor**
    - **Good electron flow**  
Silver, copper, gold, aluminum  
Free Electrons
  - **Insulator**
    - **No electron flow**  
Glass, air, plastic, porcelain
- 

**T5A07**

Why are metals generally good conductors of electricity?

- A. They have relatively high density
- B. They have many free electrons
- C. They have many free protons
- D. All these choices are correct

**T5A08**

Which of the following is a good electrical insulator?

- A. Copper
- B. Glass
- C. Aluminum
- D. Mercury

# DC

## DC or direct current

Current flows in one direction only

Resistance

**Automotive = 12 volts DC**

---

# AC

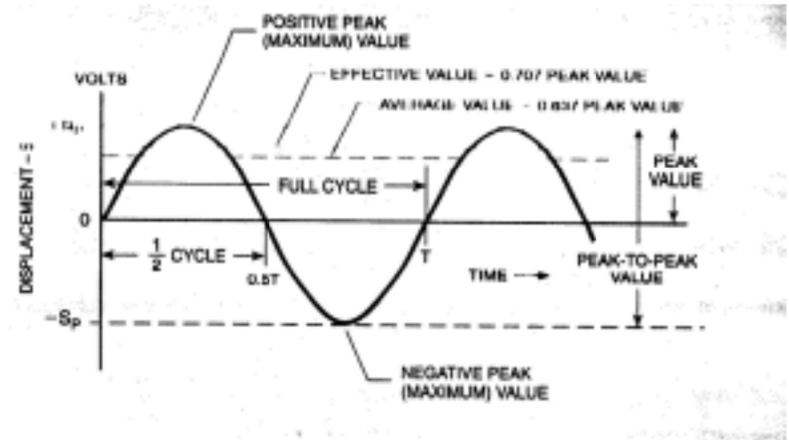

- **AC or alternating current**

- Current changes direction
- Reactance or Impedance in Ohms
- Measured in
  - Root Mean Square (rms) 0.707 of peak
    - Same Heat as DC voltage
  - Peak to Peak 2.828 X rms
  - Peak 1.414 X rms

- **House voltage = 117 volts**

- 60 hertz



**T5A09**

**Which of the following describes alternating current?**

- A. Current that alternates between a positive direction and zero
- B. Current that alternates between a negative direction and zero
- C. Current that alternates between positive and negative directions
- D. All these answers are correct

# RESISTOR

**Resistors Dissipate Power & Control or Limit Current**

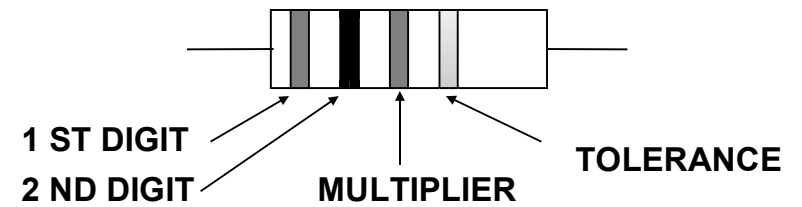
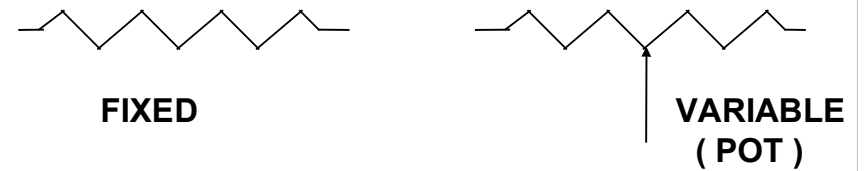

- |          |          |
|----------|----------|
| 0 BLACK  | 5 GREEN  |
| 1 BROWN  | 6 BLUE   |
| 2 RED    | 7 VIOLET |
| 3 ORANGE | 8 GRAY   |
| 4 YELLOW | 9 WHITE  |

- |              |
|--------------|
| 20 % NONE    |
| 10 % SILVER  |
| 5 % GOLD     |
| .1 % SPECIAL |

**T6A02**

**What type of component is often used as an adjustable volume control?**

- A. Fixed resistor
- B. Power resistor
- C. Potentiometer
- D. Transformer

**T6A03**

**What electrical parameter is controlled by a potentiometer?**

- A. Inductance
- B. Resistance
- C. Capacitance
- D. Field strength

The correct answer is not present (VOLTAGE)

# RESISTORS

• **In series add**  $R_T = R_1 + R_2 + R_3$

• **In parallel**

$$\frac{1}{R_T} = \frac{1}{R_1} + \frac{1}{R_2} + \frac{1}{R_3}$$

- **2 equal values in parallel = one half the value**  
**2 100 ohm resistors = 50 ohms**  
**Always less than either resistor**
- **Temperature coefficient**
  - **Plus, Minus, Zero**
- **Wire-wound resistors are inductive**

# INDUCTOR

- Opposes a change of current
- Stores energy in a magnetic field
- Series connected add
- Parallel Smaller than the smallest
- Have Mutual Inductance
  - 90 Degrees to minimize
- **$X_L = 2\pi fL$  in Ohms**
- Toroidal
  - More bang for the buck
  - No stray magnetic field

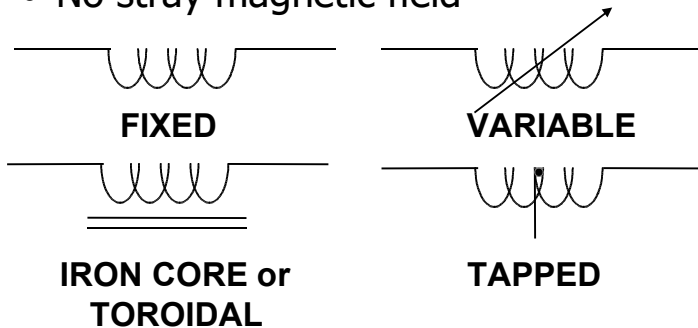

## T5C03

**What is the ability to store energy in a magnetic field called?**

- A. Admittance
- B. Capacitance
- C. Resistance
- D. Inductance

## T5C04

**What is the basic unit of inductance?**

- A. The coulomb
- B. The farad
- C. The henry
- D. The ohm

## T6A01

**What electrical component opposes the flow of current in a DC circuit?**

- A. Inductor
- B. Resistor
- C. Voltmeter
- D. Transformer

**T6A06**

**What type of electrical component stores energy in a magnetic field?**

- A. Resistor
- B. Capacitor
- C. Inductor
- D. Diode

**T6A07**

**What electrical component is typically constructed as a coil of wire?**

- A. Switch
- B. Capacitor
- C. Diode
- D. Inductor

# CAPACITOR

- Opposes a change in voltage
- Stores energy in an electrostatic field
- Blocks DC
- Passes AC
- Parallel connected add
- Series smaller than the smallest
- Ceramic
  - Low cost
- Electrolytic
  - Large values
  - Polarity

$$X_c = \frac{1}{2\pi fC} \text{ in Ohms}$$

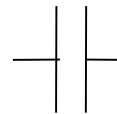

**FIXED**

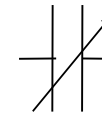

**VARIABLE**

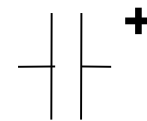

**ELECTROLYTIC**

**T5C02**

**What is the unit of capacitance?**

- A. The farad
- B. The ohm
- C. The volt
- D. The henry

**T6A04**

**What electrical component stores energy in an electric field?**

- A. Resistor
- B. Capacitor
- C. Inductor
- D. Diode

**T6A05**

**What type of electrical component consists of conductive surfaces separated by an insulator?**

- A. Resistor
- B. Potentiometer
- C. Oscillator
- D. Capacitor

**T5C01**

**What describes the ability to store energy in an electric field called?**

- A. Inductance
- B. Resistance
- C. Tolerance
- D. Capacitance

# Resonant Circuits

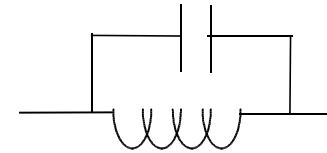

## Series

- Low impedance at resonance

## Parallel

- High impedance at resonance
- 

**T6D08**

**Which of the following is combined with an inductor to make a tuned circuit?**

- A. Resistor
- B. Zener diode
- C. Potentiometer
- D. Capacitor

**T6D11**

**Which of the following is a resonant or tuned circuit?**

- A. An inductor and a capacitor connected in series or parallel
- B. A type of voltage regulator
- C. A resistor circuit used for reducing standing wave ratio
- D. A circuit designed to provide high-fidelity audio

## OHM'S LAW

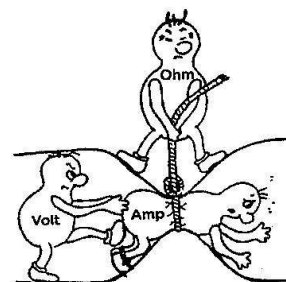

$$E = IR$$

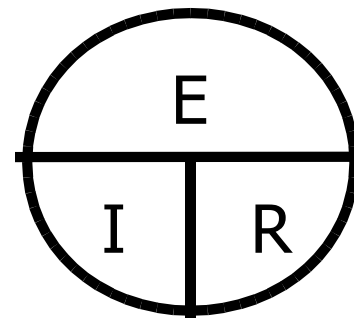

$$I = \frac{E}{R}$$
$$R = \frac{E}{I}$$

**T5D01**

**What formula is used to calculate current in a circuit?**

- A.  $I = E \times R$
- B.  $I = E / R$
- C.  $I = E + R$
- D.  $I = E - R$

**T5D02**

**What formula is used to calculate voltage in a circuit?**

- A.  $E = I \times R$
- B.  $E = I / R$
- C.  $E = I + R$
- D.  $E = I - R$

**T5D03**

**What formula is used to calculate resistance in a circuit?**

- A.  $R = E \times I$
- B.  $R = E / I$
- C.  $R = E + I$
- D.  $R = E - I$

**T5D04**

**What is the resistance of a circuit in which a current of 3 amperes flows when connected to 90 volts?**

- A. 3 ohms
- B. 30 ohms
- C. 93 ohms
- D. 270 ohms

**T5D05**

**What is the resistance in a circuit for which the applied voltage is 12 volts and the current flow is 1.5 amperes?**

- A. 18 ohms
- B. 0.125 ohms
- C. 8 ohms
- D. 13.5 ohms

**T5D06**

**What is the resistance of a circuit that draws 4 amperes from a 12-volt source?**

- A. 3 ohms
- B. 16 ohms
- C. 48 ohms
- D. 8 ohms

**T5D07**

**What is the current in a circuit with an applied voltage of 120 volts and a resistance of 80 ohms?**

- A. 9600 amperes
- B. 200 amperes
- C. 0.667 amperes
- D. 1.5 amperes

**T5D08**

**What is the current through a 100-ohm resistor connected across 200 volts?**

- A. 20,000 amperes
- B. 0.5 amperes
- C. 2 amperes
- D. 100 amperes

**T5D09**

**What is the current through a 24-ohm resistor connected across 240 volts?**

- A. 24,000 amperes
- B. 0.1 amperes
- C. 10 amperes
- D. 216 amperes

**T5D11**

**What is the voltage across a 10-ohm resistor if a current of 1 ampere flows through it?**

- A. 1 volt
- B. 10 volts
- C. 11 volts
- D. 9 volts

**T5D12**

**What is the voltage across a 10-ohm resistor if a current of 2 amperes flows through it?**

- A. 8 volts
- B. 0.2 volts
- C. 12 volts
- D. 20 volts

**T5D10**

**What is the voltage across a 2-ohm resistor if a current of 0.5 amperes flows through it?**

- A. 1 volt
- B. 0.25 volts
- C. 2.5 volts
- D. 1.5 volts



# AC Resistance Impedance Matching

If Source = Load

Max Power Transfer



If Load = Short Then No Power in Load  
If Load = Open Then No Power in Load

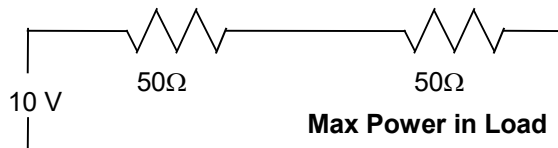

**T5C12**

**What is impedance?**

- A. A measure of the opposition to AC current flow
- B. The inverse of resistance
- C. The Q or Quality Factor of a component
- D. The power handling capability of a component

**T5C05**

**What is a unit of impedance?**

- A. Volts
- B. Amperes
- C. Coulombs
- D. Ohms

## POWER LAW

$$P = E I$$

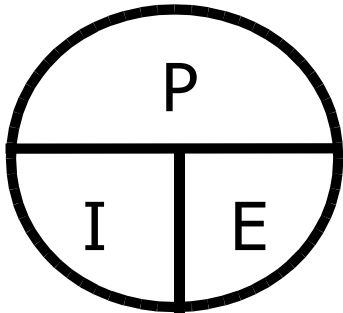

$$I = \frac{P}{E}$$

$$E = \frac{P}{I}$$

### OTHER FORMS

$$P = \frac{E^2}{R}$$

$$P = I^2 R$$

$$E = \sqrt{P R}$$

$$I = \sqrt{\frac{P}{R}}$$

### T5C08

What is the formula used to calculate electrical power in a DC circuit?

- A.  $P = E * I$
- B.  $P = E / I$
- C.  $P = E - I$
- D.  $P = E + I$

### T5C09

How much power is being used in a circuit when the applied voltage is 13.8 volts DC and the current is 10 amperes?

- A. 138 watts
- B. 0.7 watts
- C. 23.8 watts
- D. 3.8 watts

### T5C10

How much power is being used in a circuit when the applied voltage is 12 volts DC and the current is 2.5 amperes?

- A. 4.8 watts
- B. 30 watts
- C. 14.5 watts
- D. 0.208 watts

**T5C11**

**How much current is required to deliver 120 watts at a voltage of 12 volts DC?**

- A. 0.1 amperes
- B. 10 amperes
- C. 12 amperes
- D. 132 amperes

# **Series Parallel**

## **Series Circuit**

**Current thru all components  
the same**

## **Parallel Circuit**

**Voltage on all components  
the same**

---

**T5D13**

**In which type of circuit is DC current the same through all components?**

- A. Series
- B. Parallel
- C. Resonant
- D. Branch

**T5D14**

**In which type of circuit is voltage the same across all components?**

- A. Series
- B. Parallel
- C. Resonant
- D. Branch

# Transformer

## Primary winding(s)

Input

## Secondary winding(s)

Output

## Turns ratio $N_p/N_s$

Voltage ratio

Impedance ratio

$$\sqrt{Z_p/Z_s} = N_p/N_s$$

## Core Saturation (Bad)

## Magnetizing Current (Losses)

## Suppressor Cap

Across Secondary

Absorbs Transients

## T6D06

What component changes 120 V AC power to a lower AC voltage for other uses?

- A. Variable capacitor
- B. Transformer
- C. Transistor
- D. Diode

# DIODE

- Solid state or Tube
- Allows current flow only in one direction
- Symbol is backwards
- Rectifier (another name for diode)
- PIV Peak Inverse Voltage (B4 it Smokes)
- Forward Voltage
  - Silicon about .6V
  - Germanium about .1V
- Parallel Diodes need Resistors
- Schottky Diode
  - Lower Capacitance

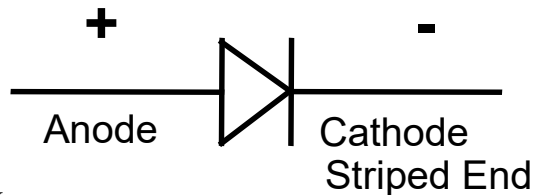

KN6FW

41

## T6B02

**What electronic component allows current to flow in only one direction?**

- A. Resistor
- B. Fuse
- C. Diode
- D. Driven element

## T6B06

**How is the cathode lead of a semiconductor diode often marked on the package?**

- A. With the word "cathode"
- B. With a stripe
- C. With the letter C
- D. With the letter K

## T6B09

**What are the names for the electrodes of a diode?**

- A. Plus and minus
- B. Source and drain
- C. Anode and cathode
- D. Gate and base

## T6B01

**Which is true about forward voltage drop in a diode?**

- A. It is lower in some diode types than in others
- B. It is proportional to peak inverse voltage
- C. It indicates that the diode is defective
- D. It has no impact on the voltage delivered to the load

KN6FW

42

# ACTIVE DEVICES

## CONTROL CURRENT

- Tube

- High voltage
- High current
- Grids
  - Control (Triode)
  - Screen (Tetrode)  
grid-to-plate capacitance
  - Suppressor (Pentode)

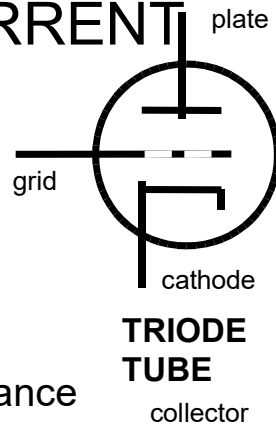

- Transistor

- Low voltage
- Saturation
- Cutoff
- May require Insulation

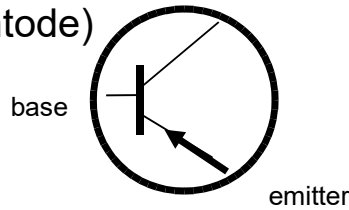

**PNP**

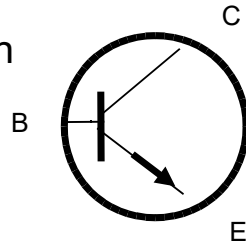

**NPN**

### T6B03

Which of these components can be used as an electronic switch or amplifier?

- A. Oscillator
- B. Potentiometer
- C. Transistor
- D. Voltmeter

### T6B05

Which of the following electronic components can amplify signals?

- A. Transistor
- B. Variable resistor
- C. Electrolytic capacitor
- D. Multi-cell battery

### T6B12

What are the names of the electrodes of a bipolar junction transistor?

- A. Signal, bias, power
- B. Emitter, base, collector
- C. Input, output, supply
- D. Pole one, pole two, output

**T6B04**

Which of the following components can consist of three regions of semiconductor material?

- A. Alternator
- B. Transistor
- C. Triode
- D. Pentagrid converter

**T6B10**

Which of the following can provide power gain?

- A. Transformer
- B. Transistor
- C. Reactor
- D. Resistor

**T6B11**

What is the term that describes a device's ability to amplify a signal?

- A. Gain
- B. Forward resistance
- C. Forward voltage drop
- D. On resistance

## More ACTIVE DEVICES

### FET Field Effect Transistor

Acts like a tube

Gate = Control Grid

Source = Cathode

Drain = Plate

### MOSFET

Insulated Gate

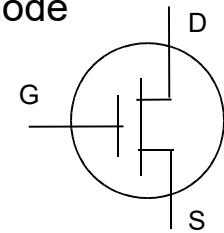

**T6B08**

What does the abbreviation FET stand for?

- A. Field Effect Transistor
- B. Fast Electron Transistor
- C. Free Electron Transmitter
- D. Frequency Emission Transmitter

**T6B05**

What type of transistor has a gate, drain, and source?

- A. Varistor
- B. Field-effect
- C. Tesla-effect
- D. Bipolar junction

# Decibel or dB

**Alexander Graham Bell**

Sound Pressure

1dB = The amount the kids turns down the volume when you tell them it's too loud

**dB = 20 Log Vo/Vin**

**dB = 10 log Po/Pin**

Log Base 10

**3 dB = 2X or ½ Power**

**10 dB = 10x or .1 Power**

**20 dB = 100X or .01 Power**

**1 S unit = 6dB**

**1dB = 10dB – 9dB or 10x - 8x or**

**About 20%**

**T5B09**

**Which decibel value most closely represents a power increase from 5 watts to 10 watts?**

- A. 2 dB
- B. 3 dB
- C. 5 dB
- D. 10 dB

**T5B10**

**Which decibel value most closely represents a power decrease from 12 watts to 3 watts?**

- A. -1 dB
- B. -3 dB
- C. -6 dB
- D. -9 dB

**T5B11**

**Which decibel value represents a power increase from 20 watts to 200 watts?**

- A. 10 dB
- B. 12 dB
- C. 18 dB
- D. 28 dB



# Rectifiers

## Full-Wave Rectifier

Converts Sine Wave to 2 Pulses

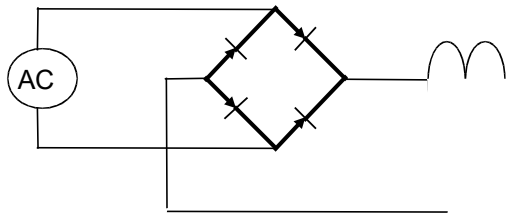

## • Half-Wave Rectifier

• Converts Sine Wave to 1 Pulse

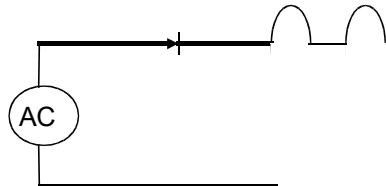

**T6D01**

**Which of the following devices or circuits changes an alternating current into a varying direct current signal?**

- A. Transformer
- B. Rectifier
- C. Amplifier
- D. Reflector

# Power Supply

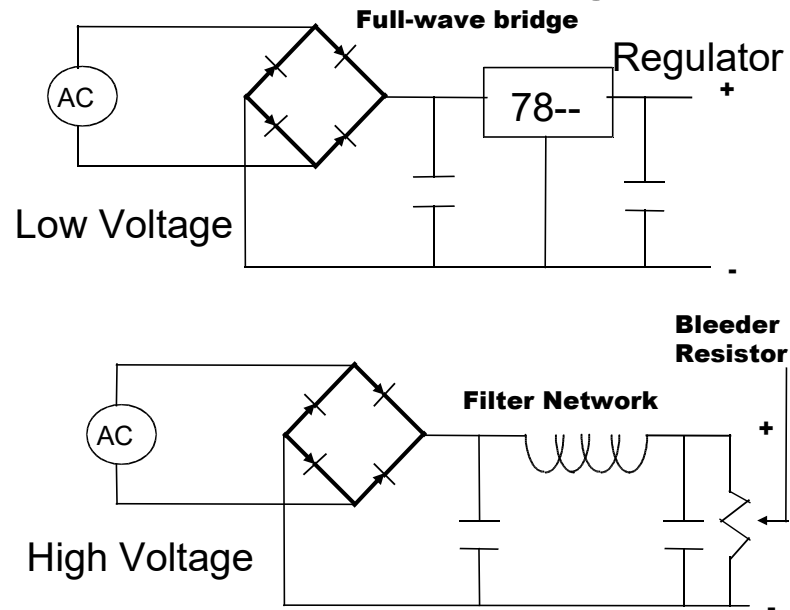

**T6D05**

What type of circuit controls the amount of voltage from a power supply?

- A. Regulator
- B. Oscillator
- C. Filter
- D. Phase inverter

**T0A11**

What hazard exists in a power supply immediately after turning it off?

- A. Circulating currents in the dc filter
- B. Leakage flux in the power transformer
- C. Voltage transients from kickback diodes
- D. Charge stored in filter capacitors

# RF Amplifiers

**Efficiency = RF power / DC power**

## Class A

Linear

Low Distortion

Can Amplify After Mod SSB

## Class C

NOT Linear

Good Efficiency

Can Amplify CW – FM

## Efficiency

Output / Input Power

## Receiver Preamp

Improve Receive signal

## T7A10

**What device increases the transmitted output power from a transceiver?**

- A. A voltage divider
- B. An RF power amplifier
- C. An impedance network
- D. All of these choices are correct

## T7A09

**What is the function of the SSB/CW-FM switch on a VHF power amplifier?**

- A. Change the mode of the transmitted signal
- B. Set the amplifier for proper operation in the selected mode
- C. Change the frequency range of the amplifier to operate in the proper portion of the band
- D. Reduce the received signal noise

## T7A11

**Where is an RF preamplifier installed?**

- A. Between the antenna and receiver
- B. At the output of the transmitter's power amplifier
- C. Between a transmitter and antenna tuner
- D. At the receiver's audio output

## Oscillator

- All oscillators use:
  - Positive Feedback
    - When a Mic Squeaks
  - Filter to Determine Frequency
    - RC Phase Shift
    - LC Tank Circuit
  - Amplification

---

### T7A05

What is the name of a circuit that generates a signal at a specific frequency?

- A. Reactance modulator
- B. Product detector
- C. Low-pass filter
- D. Oscillator

## Battery Technology Rechargeable 1

- Lead acid
  - Car battery / Sealed Cell
    - 2 Volts per cell
    - 6 Cells 12 Volt
    - Do not Discharge below 10.5 volt
    - Match Discharge rate to battery
    - Do not charge at high current
      - Can over heat
      - Hydrogen gas
      - Explode
- NiCd / NiMH
  - Battery Packs
    - 1.2 Volts per cell
    - Memory
    - Self Discharge 10% per Month
    - Flat Discharge
    - Low internal resistance
      - More current available

# Battery Technology

## Rechargeable 2

### Lithium

- Battery Packs
    - 3.6 Volts per cell
    - High Power / Price
    - Slope Discharge
- 

#### T6A10

**Which of the following battery types is rechargeable?**

- A. Nickel-metal hydride
- B. Lithium-ion
- C. Lead-acid gel-cell
- D. All of these choices are correct

#### T0A10

**What hazard is caused by charging or discharging a battery too quickly?**

- A. Overheating or out-gassing
- B. Excess output ripple
- C. Half-wave rectification
- D. Inverse memory effect

# Battery Technology

## Rechargeable 2

### Lithium

- Battery Packs
    - 3.6 Volts per cell
    - High Power / Price
    - Slope Discharge
- 

#### T6A10

**Which of the following battery types is rechargeable?**

- A. Nickel-metal hydride
- B. Lithium-ion
- C. Lead-acid gel-cell
- D. All of these choices are correct

#### T0A10

**What hazard is caused by charging or discharging a battery too quickly?**

- A. Overheating or out-gassing
- B. Excess output ripple
- C. Half-wave rectification
- D. Inverse memory effect

## Battery Technology 2 Not Rechargeable

- **Alkaline**
  - 1.5 Volts per cell
  - Slope Discharge
  - Long Shelf Life
- **Carbon-Zinc**
  - 1.5 Volts per cell
  - Low Power

---

T6A11

Which of the following battery chemistries is not rechargeable?

- A. Nickel-cadmium
- B. Carbon-zinc
- C. Lead-acid
- D. Lithium-ion

## More Battery Stuff

### Best Energy Usage Below .1C Safety

- Do NOT Short
- Do NOT Open
- Do NOT Spill
- Do NOT Over Charge
  - Hydrogen Gas
- High Current Danger

### Storage

- Keep cool
- Recharge Periodically

### Keep from Physical Damage

**T0A01**

**Which of the following is a safety hazard of a 12-volt storage battery?**

- A. Touching both terminals with the hands can cause electrical shock
- B. Shorting the terminals can cause burns, fire, or an explosion
- C. RF emissions from a nearby transmitter can cause the electrolyte to emit poison gas
- D. All these choices are correct

## Battery Amp Hour

**The amount of energy in a battery**

- A 10 AH battery
  - 10 amps for 1 hour
  - 1 amp for 10 hours
- The higher the current the lower the total energy

---

**T4A09**

**How can you determine the length of time that equipment can be powered from a battery?**

- A. Divide the watt-hour rating of the battery by the peak power consumption of the equipment
- B. Divide the battery ampere-hour rating by the average current draw of the equipment
- C. Multiply the watts per hour consumed by the equipment by the battery power rating
- D. Multiply the square of the current rating of the battery by the input resistance

## Alternator Whine

- No You Don't Drink It
- The Alternator Makes AC
- Diodes Make it DC
- The Faster it Turns the Higher the Frequency
- Can Be Filtered out

## Powering Radios

- 100W Radio = About 20 Amps
- Most new radios are 12 volt
- Power supply if at home
  - $.02\Omega$  At 20 Amps = .4 Volts
  - $13.8 - .4 = 13.4$  Volts
  - Now Your Radio is at 13.4 Volts
  - Use Big Wire
  - Connect to the Battery
    - (Not on newer cars)
      - Positive Fuse it
      - Ground Fuse it (not recommended)
  - Cigarette Lighter is NOT IT!

---

### T4A11

**A is the answer for the test,**

**Where should the negative power return of a mobile transceiver be connected in a vehicle?**

- A. At the 12 volt battery chassis ground
- B. At the antenna mount
- C. To any metal part of the vehicle (correct location)
- D. Through the transceiver's mounting bracket



# Powering Radios

- **100W Radio = About 20 Amps**
  - **Most new radios are 12 volt**
  - **Power supply if at home**
    - $.02\Omega$  At 20 Amps = .4 Volts
    - $13.8 - .4 = 13.4$  Volts
    - Now Your Radio is at 13.4 Volts
    - Use Big Wire
    - Connect to the Battery
      - (Not on newer cars)
        - Positive Fuse it
        - Ground Fuse it (not recommended)
    - Cigarette Lighter is NOT IT!
- 

## T4A11

**A is the answer for the test,**

**Where should the negative power return of a mobile transceiver be connected in a vehicle?**

- A. At the 12 volt battery chassis ground
- B. At the antenna mount
- C. To any metal part of the vehicle (**correct location**)
- D. Through the transceiver's mounting bracket

## T4A01

**Which of the following is an appropriate power supply rating for a typical 50 watt output mobile FM transceiver?**

- A. 24.0 volts at 4 amperes
- B. 13.8 volts at 4 amperes
- C. 24.0 volts at 12 amperes
- D. 13.8 volts at 12 amperes

## T4A03

**Why are short, heavy-gauge wires used for a transceiver's DC power connection?**

- A. To minimize voltage drop when transmitting
- B. To provide a good counterpoise for the antenna
- C. To avoid RF interference
- D. All these choices are correct

## Circuit Diagram

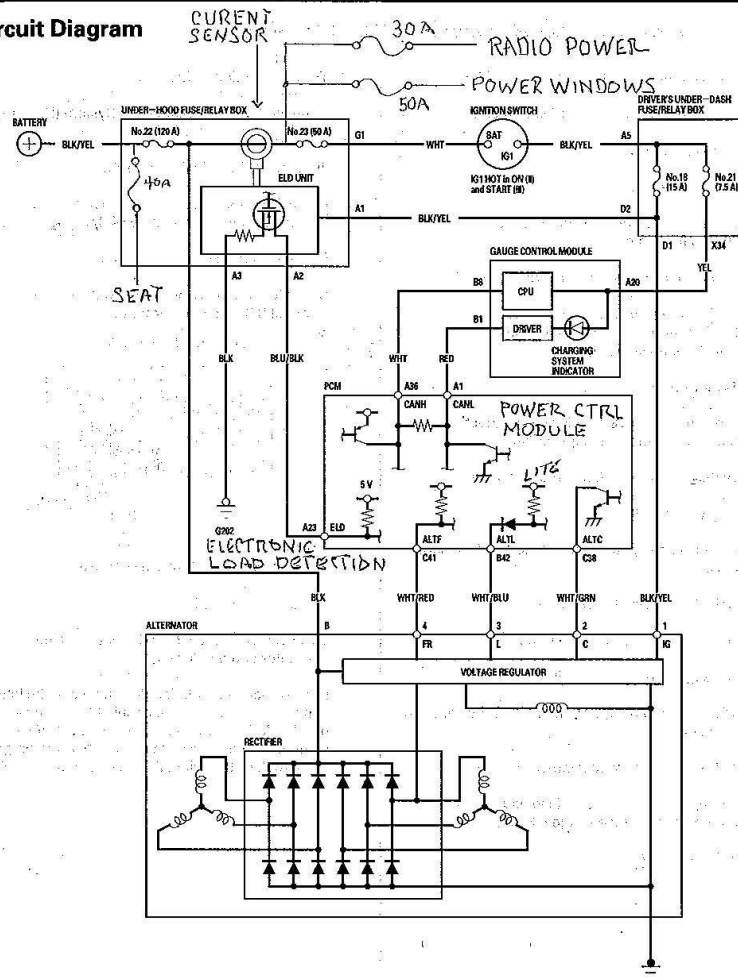

KN6FW

67

## Soldering

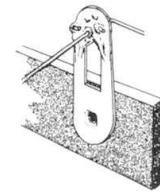

PROPER SOLDER CONNECTION

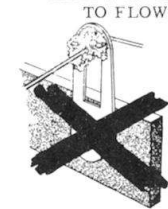

COLD SOLDER JOINT CONNECTION MOVED WHILE COOLING

- Heat the connection
- Apply solder to the connection
- Use 60/40 Lead/Tin solder
- Use Rosin NOT Acid Core
- Don't make "cold solder joint"

KN6FW

68

**T7D08**

**Which of the following types of solder should **not** be used for radio and electronic applications?**

- A. Acid-core solder
- B. Lead-tin solder
- C. Rosin-core solder
- D. Tin-copper solder

**T7D09**

**What is the characteristic appearance of a cold tin-lead solder joint?**

- A. Dark black spots
- B. A bright or shiny surface
- C. A rough or lumpy surface
- D. Excessive solder

# Modulation

## Adding information to radio signal

- CW – Turn Transmitter on and off
- AM – Change Strength
- SSB – One ½ of AM
- FM – Change Frequency
- FSK – Frequency shift keying

---

**T7A08 (C)**

**Which of the following describes combining speech with an RF carrier signal?**

- A. Impedance matching
- B. Oscillation
- C. Modulation
- D. Low-pass filtering

## AM

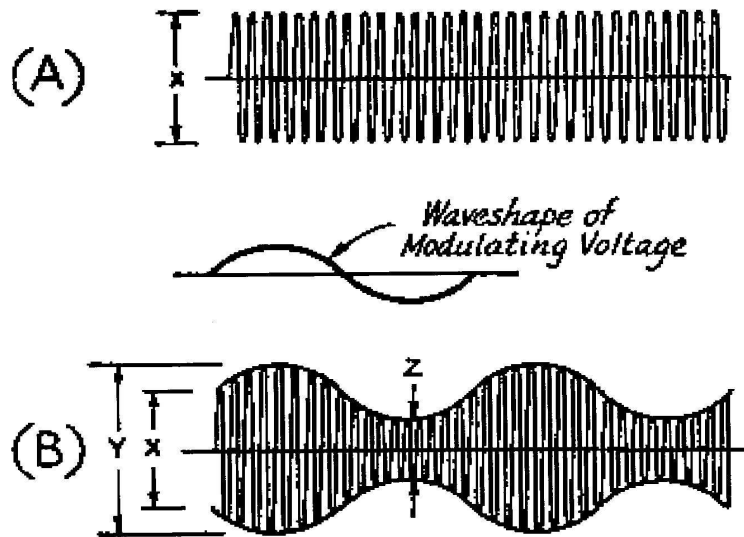

71

## Single Sideband

Similar to AM

But only one sideband

With the Carrier Suppressed

Puts more power where it counts

Difficult to tune in

Sounds like Donald Duck

---

T8A01

Which of the following is a form of amplitude modulation?

- A. Spread spectrum
- B. Packet radio
- C. Single sideband
- D. Phase shift keying (PSK)

72

# FM

**Frequency Modulation**

**Phase Modulation**

**Uses a Reactance Modulator**

**Changes phase angle**

**Both produce FM**

**Off frequency**

- Distorts receive signal

**Over modulation**

- Uses more bandwidth
  - Interferes with the next channel
  - Distorts receive signal
- Quick fix
  - Talk softer or away from the mic.

**Bandwidth = Deviation times the Audio Frequency**

**5kHz Dev X 3kHz Audio = 15kHz** 73

**T7B01**

**What can you do if you are told your FM handheld or mobile transceiver is over-deviating?**

- A. Talk louder into the microphone
- B. Let the transceiver cool off
- C. Change to a higher power level
- D. Talk farther away from the microphone

**T2B05**

**What would cause your FM transmission audio to be distorted on voice peaks?**

- A. You have the incorrect offset
- B. You need to talk louder
- C. You are talking too loudly
- D. Your transmit power is too high

**T4B12**

**What is the result of tuning an FM receiver above or below a signal's frequency?**

- A. Change in audio pitch
- B. Sideband inversion
- C. Generation of a heterodyne tone
- D. Distortion of the signal's audio

**T7B01**

**What can you do if you are told your FM handheld or mobile transceiver is over-deviating?**

- A. Talk louder into the microphone
- B. Let the transceiver cool off
- C. Change to a higher power level
- D. Talk farther away from the microphone

**T2B05**

**What would cause your FM transmission audio to be distorted on voice peaks?**

- A. You have the incorrect offset
- B. You need to talk louder
- C. You are talking too loudly
- D. Your transmit power is too high

**T4B12**

**What is the result of tuning an FM receiver above or below a signal's frequency?**

- A. Change in audio pitch
- B. Sideband inversion
- C. Generation of a heterodyne tone
- D. Distortion of the signal's audio

## Test Equipment

- **S Meter on your radio**
  - Relative signal strength
  - Each model radio is different
  - 1 S unit about 6 dB or 4 times
  - 20 dB = 100 times

# Multimeter

- **Digital are more accurate**
- **Analog for tuning circuits**
- **Measures**
  - **Volts AC and DC**
    - Voltmeter
  - **Ohms**
    - Ohm meter
  - **Current Mostly DC Some AC**
    - Amp meter
  - **Some Measure Capacitance +**
  - High input impedance
    - Less load on the circuit

**T7D07**

**Which of the following measurements are commonly made using a multimeter?**

- A. Signal strength and noise
- B. Impedance and reactance
- C. Voltage and resistance
- D. All these choices are correct

**T6D04**

**Which of the following displays an electrical quantity as a numeric value?**

- A. Potentiometer
- B. Transistor
- C. Meter
- D. Relay

## Using Meters

- **Make sure you are on the correct scale**
  - Using the wrong scale “POOF”
  - Don’t measure Voltage on resistance scales
- **Measure voltage in parallel**
  - Check rating for high voltage
- **Measure current in series**
- **Measure resistance out of circuit or with power off in parallel**
- **Resistance of capacitor will increase with time**

### T7D02

**How is a voltmeter connected to a component to measure applied voltage?**

- A. In series with the circuit
- B. In parallel with the circuit
- C. In quadrature with the circuit
- D. In phase with the circuit

### T7D03

**When configured to measure current, how is a multimeter connected to a component?**

- A. In series
- B. In parallel
- C. In quadrature
- D. In phase

### T7D05

**How is an ohmmeter connected to a component to measure its resistance?**

- A. In parallel
- B. In series
- C. In cascade
- D. All these choices are correct

### T7D04

**Which instrument is used to measure electric current?**

- A. An ohmmeter
- B. A wavemeter
- C. A voltmeter
- D. An ammeter



**T7D01**

**Which instrument would you use to measure electric potential?**

- A. An ammeter
- B. A voltmeter
- C. A wavemeter
- D. An ohmmeter

**T7D10**

**What reading indicates that an ohmmeter is connected across a large, discharged capacitor?**

- A. Increasing resistance with time
- B. Decreasing resistance with time
- C. Steady full-scale reading
- D. Alternating between open and short circuit

**T7D11**

**Which of the following precautions should be taken when measuring circuit resistance with an ohmmeter?**

- A. Ensure that the applied voltages are correct
- B. Ensure that the circuit is not powered
- C. Ensure that the circuit is grounded
- D. Ensure that the circuit is operating at the correct frequency

**T0A12**

**Which of the following precautions should be taken when measuring high voltages with a voltmeter?**

- A. Ensure that the voltmeter has very low impedance
- B. Ensure that the voltmeter and leads are rated for use at the voltages to be measured
- C. Ensure that the circuit is grounded through the voltmeter
- D. Ensure that the voltmeter is set to the correct frequency

**T7D06**

**Which of the following might damage a multimeter?**

- A. Measuring a voltage too small for the chosen scale
- B. Leaving the meter in the milliamps position overnight
- C. Attempting to measure voltage when using the resistance setting
- D. Not allowing it to warm up properly

# Other Test Equipment

- **Antenna Analyzer**
  - Check SWR of an antenna
  - Tune an antenna
  - Check coax impedance
- **Directional Watt meter**
  - SWR ( you need to calculate )
- **Dummy Load**
  - Tune or fix your radio and not radiate
    - 50 Ohm non-inductive Resistor
- **Field Strength Meter**
  - Antenna Pattern
  - Monitor RF output

## T7C03

**What does a dummy load consist of?**

- A. A high-gain amplifier and a TR switch
- B. A non-inductive resistor and a heat sink
- C. A low-voltage power supply and a DC relay
- D. A 50 ohm reactance used to terminate a transmission line

## T7C01

**What is the primary purpose of a dummy load?**

- A. To prevent transmitting signals over the air when making tests
- B. To prevent over-modulation of a transmitter
- C. To improve the efficiency of an antenna
- D. To improve the signal-to-noise ratio of a receiver

## T7C02

**Which of the following instruments can be used to determine if an antenna is resonant at the desired operating frequency?**

- A. A VTVM
- B. An antenna analyzer
- C. A Q meter
- D. A frequency counter

# Integrated Circuits 1

- **Analog**
  - Voltage regulator
  - Operational amplifier
  - MMIC
    - Monolithic Microwave IC
- **Display – LED**
  - Light emitting diode
    - Forward bias
    - Low power
  - LCD Liquid crystal display
    - Light polarization method
    - Back Lit or Reflected
- **Microcontroller - Microprocessor**
  - Programmable

## T6B07

**What causes a light-emitting diode (LED) to emit light?**

- A. Forward current
- B. Reverse current
- C. Capacitively-coupled RF signal
- D. Inductively-coupled RF signal

## T6D07

**Which of the following is commonly used as a visual indicator?**

- A. LED
- B. FET
- C. Zener diode
- D. Bipolar transistor

## T6D09

**What is the name of a device that combines several semiconductors and other components into one package?**

- A. Transducer
- B. Multi-pole relay
- C. Integrated circuit
- D. Transformer

# Switches & Relays

- **Switches**

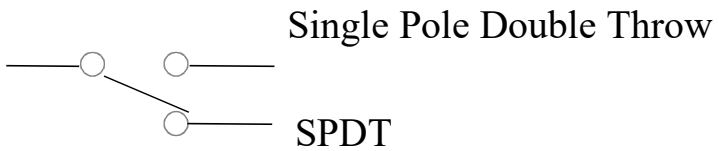

DPST

DPDT

## Relay

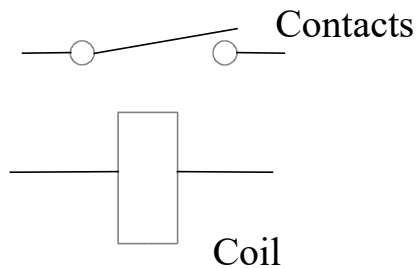

**T6D02**

**What is a relay?**

- A. An electrically-controlled switch
- B. A current controlled amplifier
- C. An optical sensor
- D. A pass transistor

**T6A08**

**What is the function of an SPDT switch?**

- A. A single circuit is opened or closed
- B. Two circuits are opened or closed
- C. A single circuit is switched between one of two other circuits
- D. Two circuits are each switched between one of two other circuits

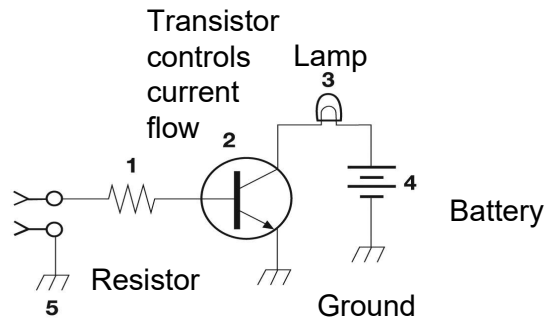

Figure T-1

**T6C01**  
**What is the name of an electrical wiring diagram that uses standard component symbols?**

- A. Bill of materials
- B. Connector pinout
- C. Schematic
- D. Flow chart

**T6C02**  
**What is component 1 in figure T1?**

- A. Resistor
- B. Transistor
- C. Battery
- D. Connector

**T6C03**  
**What is component 2 in figure T1?**

- A. Resistor
- B. Transistor
- C. Indicator lamp
- D. Connector

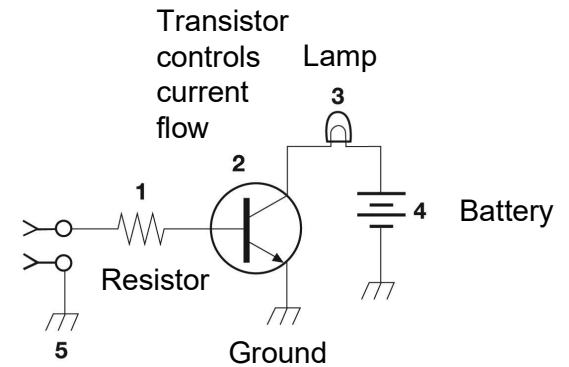

Figure T-1

**T6C04**  
**What is component 3 in figure T1?**

- A. Resistor
- B. Transistor
- C. Lamp
- D. Ground symbol

**T6C05**  
**What is component 4 in figure T1?**

- A. Resistor
- B. Transistor
- C. Battery
- D. Ground symbol

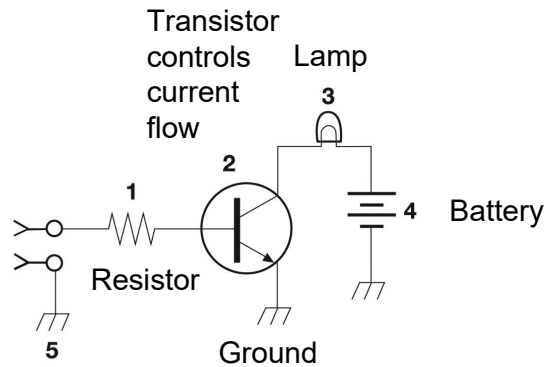

Figure T-1

**T6D10**

**What is the function of component 2 in Figure T1?**

- A. Give off light when current flows through it
- B. Supply electrical energy
- C. Control the flow of current
- D. Convert electrical energy into radio waves

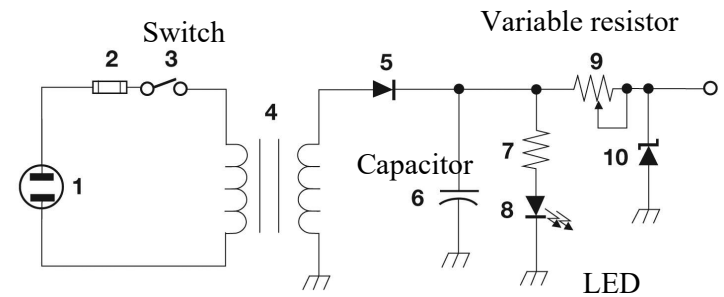

Figure T-2

**T6C06**

**What is component 6 in figure T2?**

- A. Resistor
- B. Capacitor
- C. Regulator IC
- D. Transistor

**T6C07**

**What is component 8 in figure T2?**

- A. Resistor
- B. Inductor
- C. Regulator IC
- D. Light emitting diode

**T6C08**

**What is component 9 in figure T2?**

- A. Variable capacitor
- B. Variable inductor
- C. Variable resistor
- D. Variable transformer

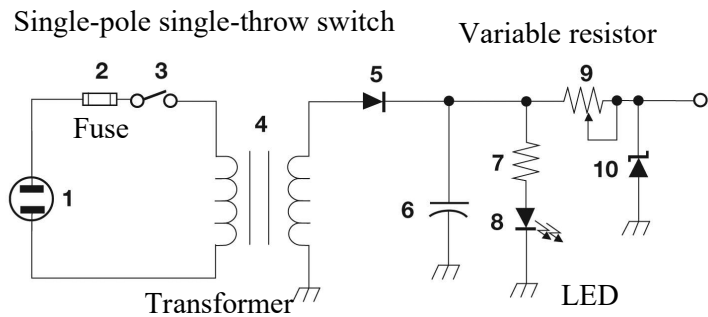

Figure T-2

**T6C09**

**What is component 4 in figure T2?**

- A. Variable inductor
- B. Double-pole switch
- C. Potentiometer
- D. Transformer

**T6A12**

**What type of switch is represented by component 3 in figure T-2?**

- A. Single-pole single-throw
- B. Single-pole double-throw
- C. Double-pole single-throw
- D. Double-pole double-throw

**T6A09**

**What electrical component is used to protect other circuit components from current overloads?**

- A. Fuse
- B. Thyatron
- C. Varactor
- D. All these choices are correct

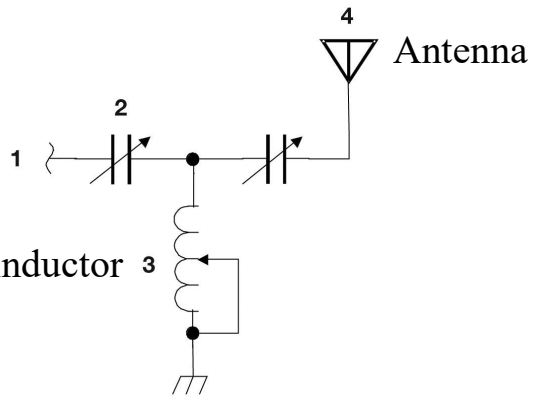

Figure T-3

**T6C10**

**What is component 3 in figure T3?**

- A. Connector
- B. Meter
- C. Variable capacitor
- D. Variable inductor

**T6C11**

**What is component 4 in figure T3?**

- A. Antenna
- B. Transmitter
- C. Dummy load
- D. Ground

**T6C12**

**Which of the following is accurately represented in electrical schematics?**

- A. Wire lengths
- B. Physical appearance of components
- C. Component connections
- D. All these choices are correct



## THE FIVE PRINCIPALS

1. Public service - emergency comm.
2. Advance the radio art
3. Improve communication & technical skills
4. Expand pool of trained operators, technicians & electronics experts
5. International goodwill

---

T1A01 [97.1]

**Which of the following is part of the Basis and Purpose of the Amateur Radio Service?**

- A. Providing personal radio communications for as many citizens as possible
- B. Providing communications for international non-profit organizations
- C. Advancing skills in the technical and communication phases of the radio art
- D. All of these choices are correct

## LICENSE REQUIREMENTS

- No age requirement
- Anyone except a **representative** of a foreign government
- Fill out form 610 & pay the \$
- PASS THE TEST!**
- FCC may inspect at any time
- Keep your address & email current
  - If the FCC can't send you mail you could lose your license
- Don't lose the original

**T1C07 [97.23]**

**Which of the following can result in revocation of the station license or suspension of the operator license?**

- A. Failure to inform the FCC of any changes in the amateur station following performance of an RF safety environmental evaluation
- B. Failure to provide and maintain a correct email address with the FCC
- C. Failure to obtain FCC type acceptance prior to using a home-built transmitter
- D. Failure to have a copy of your license available at your station

**T1F01 [97.103(c)]**

**When must the station licensee make the station and its records available for FCC inspection?**

- A. At any time ten days after notification by the FCC of such an inspection
- B. At any time upon request by an FCC representative
- C. Only after failing to comply with an FCC notice of violation
- D. Only when presented with a valid warrant by an FCC official or government agent

# THE TEST

## VOLUNTEER EXAMINER (VE)

*Ham operators that administer the ham test "for free"*

### Test Elements

- 2 Tech
- 3 General
- 4 Extra

Certificate of Completion for elements passed are good for 1 year

- To give a tech exam
  - 3 VEs Present
  - 18 Years old or older
  - Hold General or higher
  - Accredited by a VEC

**T1C01 [97.9(a), 97.17(a)]**

**For which license classes are new licenses currently available from the FCC?**

- A. Novice, Technician, General, Advanced
- B. Technician, Technician Plus, General, Advanced
- C. Novice, Technician Plus, General, Advanced
- D. Technician, General, Amateur Extra

## **Credit for Expired License**

**General Class or Higher  
Must Pass Element 2**

# HAM LICENSE

## Operators license

License class - determines privileges

One license per person

Authorization to operate

In FCC database

## Station license

Call sign

Address of primary station

Written authorization for station

Must be in the FCC database

May operate any number of transmitters

Responsible for operation

Post or carry A COPY

Required to operate on HAM bands

### T1A04 [97.5(b)(1)]

**How many operator/primary station license grants may be held by any one person?**

- A. One
- B. No more than two
- C. One for each band on which the person plans to operate
- D. One for each permanent station location from which the person plans to operate

### T1E04 [97.103(b)]

**What determines the transmitting privileges of an amateur station?**

- A. The frequency authorized by the frequency coordinator
- B. The frequencies printed on the license grant
- C. The highest class of operator license held by anyone on the premises
- D. The class of operator license held by the control Operator

### T1C10 [97.5a]

**How soon after passing the examination for your first amateur radio license may you operate a transmitter on an Amateur Radio Service frequency?**

- A. Immediately
- B. 30 days after the test date
- C. As soon as your operator/station license grant appears in the FCC's license database
- D. You must wait until you receive your license in the mail from the FCC

**T1A05 [97.7]**

**What proves that the FCC has issued an operator/primary license grant?**

- A. A printed copy of the certificate of successful completion of examination
- B. An email notification from the NCVEC granting the license
- C. The license appears in the FCC ULS database
- D. All these choices are correct

# LICENSE TERM

**10 YEARS**

**Renew 60 - 90 days before it expires!  
2 year grace period - NO Transmit  
Renew with 610 form  
And the \$35**

---

**T1C09 [97.21(a)(b)]**

**What is the grace period for renewal if an amateur license expires?**

- A. Two years
- B. Three years
- C. Five years
- D. Ten years

**T1C08 [97.25]**

**What is the normal term for an FCC-issued amateur radio license?**

- A. Five years
- B. Life
- C. Ten years
- D. Twenty years

**T1C11 [97.21(b)]**

**If your license has expired and is still within the allowable grace period, may you continue to operate a transmitter on Amateur Radio Service frequencies?**

- A. Yes, for up to two years
- B. Yes, as soon as you apply for renewal
- C. Yes, for up to one year
- D. No, you must wait until the license has been renewed

# CALL SIGNS

**US Calls Start with **A, K, N,** or **W**  
Assigned Sequentially**

---

## Group **A** - Extra

**1 by 2 (K6TS) 2 by 1 (AD6X) 2 by 2 (AB6CR)**

## Group **B** - Advanced

**2 by 2 (KN6FW)**

## Group **C** - General/Tech

**1 by 3 (N6FQQ)**

## Group **D** - NOVICE

**2 by 3 (KD6TOJ)**

## Special Event

**1 by 1**

**(N6A)**

## Vanity Call

**K6FOX**

## Club Call

**4 Members**

**T1C02 [97.19]**

**Who may select a desired call sign under the vanity call sign rules?**

- A. Only a licensed amateur with a General or Amateur Extra class license
- B. Only a licensed amateur with an Amateur Extra class license
- C. Only a licensed amateur who has been licensed continuously for more than 10 years
- D. Any licensed amateur

**T1C05**

**Which of the following is a valid Technician class call sign format?**

- A. KF1XXX
- B. KA1X
- C. W1XX
- D. All these choices are correct

**T1F06 [97.119(c)]**

**Which of the following formats of a self-assigned indicator is acceptable when identifying using a phone transmission?**

- A. KL7CC stroke W3
- B. KL7CC slant W3
- C. KL7CC slash W3
- D. All of these choices are correct

**T1F11 [97.5(b)(2)]**

**Which of the following is a requirement for the issuance of a club station license grant?**

- A. The trustee must have an Amateur Extra class operator license grant
- B. The club must have at least four members
- C. The club must be registered with the American Radio Relay League
- D. All of these choices are correct

# CONTROL OPERATOR

- **Must have ham license**
- **Responsible for station**
- **May operate multiple transmitters**
- **Only allowed privileges of control operator**
- **Control operator may be chosen by station licensee**
- **You do not have to keep records of the chosen control operator**

# CONTROL POINT

- **Location where the control operator function is preformed**
- **Local, Remote or Automatic**

## **T1E01 [97.7(a)]**

**When may an amateur station transmit without a control operator?**

- A. When using automatic control, such as in the case of a repeater
- B. When the station licensee is away and another licensed amateur is using the station
- C. When the transmitting station is an auxiliary station
- D. Never

## **T1E03 [97.103(b)]**

**Who must designate the station control operator?**

- A. The station licensee
- B. The FCC
- C. The frequency coordinator
- D. The ITU

## **T1E06 [97.301]**

**When, under normal circumstances, may a Technician class licensee be the control operator of a station operating in an exclusive Amateur Extra class operator segment of the amateur bands?**

- A. At no time
- B. When operating a special event station
- C. As part of a multi-operator contest team
- D. When using a club station whose trustee is an Amateur Extra class operator licensee



**T1E01 [97.7(a)]**

**When may an amateur station transmit without a control operator?**

- A. When using automatic control, such as in the case of a repeater
- B. When the station licensee is away and another licensed amateur is using the station
- C. When the transmitting station is an auxiliary station
- D. Never

**T1E03 [97.103(b)]**

**Who must designate the station control operator?**

- A. The station licensee
- B. The FCC
- C. The frequency coordinator
- D. The ITU

**T1E06 [97.301]**

**When, under normal circumstances, may a Technician class licensee be the control operator of a station operating in an exclusive Amateur Extra class operator segment of the amateur bands?**

- A. At no time
- B. When operating a special event station
- C. As part of a multi-operator contest team
- D. When using a club station whose trustee is an Amateur Extra class operator licensee

**T1E05 [97.3(a)(14)]**

**What is an amateur station control point?**

- A. The location of the station's transmitting antenna
- B. The location of the station transmitting apparatus
- C. The location at which the control operator function is performed
- D. The mailing address of the station licensee

**T1E07 [97.103(a)]**

**When the control operator is not the station licensee, who is responsible for the proper operation of the station?**

- A. All licensed amateurs who are present at the operation
- B. Only the station licensee
- C. Only the control operator
- D. The control operator and the station licensee are equally responsible

**T1E09 [97.109(c)]**

**Which of the following are required for remote control operation?**

- A. The control operator must be at the control point
- B. A control operator is required at all times
- C. The control operator indirectly manipulates the controls
- D. All of these choices are correct

**T1E10 [97.3(a)(39)]**

**Which of the following is an example of remote control as defined in Part 97?**

- A. Repeater operation
- B. Operating the station over the internet
- C. Controlling a model aircraft, boat, or car by amateur radio
- D. All of these choices are correct

**T1E11 [97.103(a)]**

**Who does the FCC presume to be the control operator of an amateur station, unless documentation to the contrary is in the station records?**

- A. The station custodian
- B. The third-party participant
- C. The person operating the station equipment
- D. The station licensee

## **STATION OPERATION**

- **Any location controlled by the FCC**
- **Vessel or craft located in international waters and documented or registered in the United States**
- **Canada has a reciprocal agreement with the USA**
- **No reciprocal agreement with Europe?**
- **May communicate only with HAM stations or stations the FCC authorize**
  - Armed Forces Day
- **Commercial aircraft \***
- **Cruise Ship\***      \*with restrictions
- **May communicate with foreign countries only if allowed by the country & the USA**

**T1C06 [97.5(a)(2)]**

**From which of the following locations may an FCC-licensed amateur station transmit?**

- A. From within any country that belongs to the International Telecommunications Union
- B. From within any country that is a member of the United Nations
- C. From anywhere within International Telecommunications Union (ITU) Regions 2 and 3
- D. From any vessel or craft located in international waters and documented or registered in the United States

## Foreign Country

- **Amateur & personal remarks**
  - **Operation in a foreign country is allowed when authorized by the foreign country**
  - **No communication with foreign countries that have notified the ITU**
- 

**T1C03 [97.117]**

**What types of international communications is an FCC-licensed amateur radio station permitted to make?**

- A. Communications incidental to the purposes of the Amateur Radio Service and remarks of a personal character
- B. Communications incidental to conducting business or remarks of a personal nature
- C. Only communications incidental to contest exchanges, all other communications are prohibited
- D. Any communications that would be permitted by an international broadcast station

# STATION ID

- **ID not required at the start**
- **ID every 10 min. & at the end**
- **ID with your call sign**
- **ID with Voice must be in English**  
(Communication may be in a different language)
- **Use standard phonetics**
  - Don't use cute words
- **CW may always be used**
- **Repeaters 20 WPM max**
- **Upgrade with /AG or Authorized General**
- **No ID required for control of models, BUT Call sign, Name, & Address must be on the transmitter and 1 Watt max.**
- **ID with your call once per hour when using a special event call sign**
- **ID with your call followed by the call sign of the station you are using**
- **ID may contain Self-assigned indicator**
  - May not confuse call sign

## **T1D11 [97.119(a)]**

**When may an amateur station transmit without identifying on the air?**

- A. When the transmissions are of a brief nature to make station adjustments
- B. When the transmissions are unmodulated
- C. When the transmitted power level is below 1 watt
- D. When transmitting signals to control model craft

## **T1F03 [97.119(a)]**

**When is an amateur station required to transmit its assigned call sign?**

- A. At the beginning of each contact, and every 10 minutes thereafter
- B. At least once during each transmission
- C. At least every 15 minutes during and at the end of a communication
- D. At least every 10 minutes during and at the end of a communication

## **T1F04 [97.119(b)(2)]**

**What language may you use for identification when operating in a phone sub-band?**

- A. Any language recognized by the United Nations
- B. Any language recognized by the ITU
- C. The English language
- D. English, French, or Spanish

**T2A06**

**Which of the following is required when making on-the-air test transmissions?**

- A. Identify the transmitting station
- B. Conduct tests only between 10 p.m. and 6 a.m. local time
- C. Notify the FCC of the transmissions
- D. All of these choices are correct

# POWER

- **TECH + max power on HF 200w**
  - **Peak envelope power (pep) 1500w max**
  - **Beacon for propagation 100w**
  - **Model control 1w**
  - **Use only minimum power needed**
  - **Measured at the transmitter output**
- 

**T1B12 [97.313(b)]**

**Except for some specific restrictions, what is the maximum peak envelope power output for Technician class operators using frequencies above 30 MHz?**

- A. 50 watts
- B. 100 watts
- C. 500 watts
- D. 1500 watts

**T1B11 [97.313]**

**What is the maximum peak envelope power output for Technician class operators in their HF band segments?**

- A. 200 watts
- B. 100 watts
- C. 50 watts
- D. 10 watts

# FCC RULES PART 97

Station Operation Standards  
Technical Standards  
Emergency Communications

**NOT**

Construction Standards

- **Good engineering practice**
- **Good amateur practice**
- **CSCE Good for 365 Days**
- **Identify with your call**
  - In English or CW
- **With CSCE for General**
  - Call +"temporary AG"
  - May Use General privileges

**T2C01 [97.103(a)]**

**When do the FCC rules NOT apply to the operation of an amateur station?**

- A. When operating a RACES station
- B. When operating under special FEMA rules
- C. When operating under special ARES rules
- D. Never, FCC rules always apply

**T1A02 [97.1]**

**Which agency regulates and enforces the rules for the Amateur Radio Service in the United States?**

- A. FEMA
- B. Homeland Security
- C. The FCC
- D. All of these choices are correct

**T1F05 [97.119(b)(2)]**

**What method of call sign identification is required for a station transmitting phone signals?**

- A. Send the call sign followed by the indicator RPT
- B. Send the call sign using a CW or phone emission
- C. Send the call sign followed by the indicator R
- D. Send the call sign using only a phone emission

# The FCC Rule Book

## “SHALL NOT”

\* Except

- Be paid for communication \***
- Profit from communication \***
- Retransmit signals \***
- Communicate with other services \***
- Broadcast or Play music\***
- Use code or ciphers\***
- One Way Transmissions\***
- Transmit False or Deceptive signals**
- Cause harmful interference**
- TX unidentified communication**
- Use obscene, indecent or profane language**
- No list, use judgment

### **T1D03 [97.211(b), 97.215(b), 97.114(a)(4)]**

**When is it permissible to transmit messages encoded to hide their meaning?**

- A. Only during contests
- B. Only when operating mobile
- C. Only when transmitting control commands to space stations or radio control craft
- D. Only when frequencies above 1280 MHz are used

### **T1D04 [97.113(a)(4), 97.113(c)]**

**Under what conditions is an amateur station authorized to transmit music using a phone emission?**

- A. When incidental to an authorized retransmission of manned spacecraft communications
- B. When the music produces no spurious emissions
- C. When the purpose is to interfere with an illegal transmission
- D. When the music is transmitted above 1280 MHz

### **T1D05 [97.113(a)(3)(ii)]**

**When may amateur radio operators use their stations to notify other amateurs of the availability of equipment for sale or trade?**

- A. Never
- B. When the equipment is not the personal property of either the station licensee, or the control operator, or their close relatives
- C. When no profit is made on the sale
- D. When selling amateur radio equipment and not on a regular basis

**T1D06 [97.113(a)(4)]**

**What, if any, are the restrictions concerning transmission of language that may be considered indecent or obscene?**

- A. The FCC maintains a list of words that are not permitted to be used on amateur frequencies
- B. Any such language is prohibited
- C. The ITU maintains a list of words that are not permitted to be used on amateur frequencies
- D. There is no such prohibition

**T1D08 [97.113(a)(3)(iii)]**

**In which of the following circumstances may the control operator of an amateur station receive compensation for operating that station?**

- A. When the communication is related to the sale of amateur equipment by the control operator's employer
- B. When the communication is incidental to classroom instruction at an educational institution
- C. When the communication is made to obtain emergency information for a local broadcast station
- D. All of these choices are correct

**T1D10 [97.3(a)(10)]**

**How does the FCC define broadcasting for the Amateur Radio Service?**

- A. Two-way transmissions by amateur stations
- B. Any transmission made by the licensed station
- C. Transmission of messages directed only to amateur operators
- D. Transmissions intended for reception by the general public

**T1D09 [97.113(5)(b)]**

**When may amateur stations transmit information in support of broadcasting, program production, or news gathering, assuming no other means is available?**

- A. When such communications are directly related to the immediate safety of human life or protection of property
- B. When broadcasting communications to or from the space shuttle
- C. Where noncommercial programming is gathered and supplied exclusively to the National Public Radio network
- D. Never

**T1D02 [97.113(b),97.111(b)]**

**Under which of the following circumstances are one-way transmissions by an amateur station prohibited?**

- A. In all circumstances
- B. Broadcasting
- C. International Morse Code Practice
- D. Telecommand or transmissions of telemetry



**T1A11 [97.101 (d)]**

**When is willful interference to other amateur radio stations permitted?**

- A. To stop another amateur station which is breaking the FCC rules
- B. At no time
- C. When making short test transmissions
- D. At any time, stations in the Amateur Radio Service are not protected from willful interference

## **FCC - REGULATION**

**Inspect your station a any time**

**Keep transmitters secure**

Key switch in the shack

Remove mic in the car

**Interference**

If you are the cause, get off the air at certain times until you fix your transmitter

**Keep your email address current**

FCC Gettysburg, PA

On the Web

**Observe antenna height limits**

200 ft

FAA

WIFE - Neighbors

**T1C04 [97.23]**

**What may happen if the FCC is unable to reach you by email?**

- A. Fine and suspension of operator license
- B. Revocation of the station license or suspension of the operator license
- C. Revocation of access to the license record in the FCC system
- D. Nothing; there is no such requirement

## **Secondary User**

**Hams get to use the frequency if they don't interfere with the Primary user**

**Big deal on 440 MHz**

---

**T1B08 [97.303]**

**How are US amateurs restricted in segments of bands where the Amateur Radio Service is secondary?**

- A. U.S. amateurs may find non-amateur stations in those segments, and must avoid interfering with them
- B. U.S. amateurs must give foreign amateur stations priority in those segments
- C. International communications are not permitted in those segments
- D. Digital transmissions are not permitted in those segments

# International Telecommunications Union

**An agency of the United Nations**

**US is in ITU Region 2**

**Management of frequency allocations**

**Countries may Notify the ITU that They  
Don't want HAMS to Talk**

---

**T1D01 [97.111(a)(1)]**

**With which countries are FCC-licensed amateur radio stations prohibited from exchanging communications?**

- A. Any country whose administration has notified the International Telecommunication Union (ITU) that it objects to such communications
- B. Any country whose administration has notified the American Radio Relay League (ARRL) that it objects to such communications
- C. Any country banned from such communications by the International Amateur Radio Union (IARU)
- D. Any country banned from making such communications by the American Radio Relay League (ARRL)

# Emergency Traffic RACES and ARES

## ARES

- (Amateur Radio Emergency Service)
- ARRL
- Voluntarily Registration
- Message Handling
- Red Cross
- Food and Shelter

## **T2C06**

### **What is the Amateur Radio Emergency Service (ARES)?**

- A. A group of licensed amateurs who have voluntarily registered their qualifications and equipment for communications duty in the public service
- B. A group of licensed amateurs who are members of the military and who voluntarily agreed to provide message handling services in the case of an emergency
- C. A training program that provides licensing courses for those interested in obtaining an amateur license to use during emergencies
- D. A training program that certifies amateur operators for membership in the Radio Amateur Civil Emergency Service

## **RACES**

- (Radio Amateur Civil Emergency service)
- Training required
- Police and Fire
- Local coordinator
- Drills
- Allowed 1 hour per week
- Must ID with drill or test message
- Use Tactical call signs
  - Must Standard ID

## **T2C04**

### **What is RACES?**

- A. An emergency organization combining amateur radio and citizens band operators and frequencies
- B. An international radio experimentation society
- C. A radio contest held in a short period, sometimes called a "sprint"
- D. An FCC part 97 amateur radio service for civil defense communications during national emergencies

## **T1F02 [97.119 (a)]**

### **How often must you identify with your FCC-assigned call sign when using tactical call signs such as "Race Headquarters"?**

- A. Never, the tactical call is sufficient
- B. Once during every hour
- C. At the end of each communication and every ten minutes during a communication
- D. At the end of every transmission

## **T1A10 [97.3(a)(38), 97.407]**

### **What is the Radio Amateur Civil Emergency Service (RACES)?**

- A. A radio service using amateur frequencies for emergency management or civil defense communications
- B. A radio service using amateur stations for emergency management or civil defense communications
- C. An emergency service using amateur operators certified by a civil defense organization as being enrolled in that organization
- D. All of these choices are correct

# **NET / TRAFFIC**

## **Net Control Station (NCS)**

- Controls Communication
- Call when you have traffic
- Call with Priority or Emergency
- Respond when called

## **Traffic**

- Formal Messages
  - Preamble – Tracking info
  - Check – Word Count
- Send as Received

**T2C02**

**Which of the following are typical duties of a Net Control Station?**

- A. Choose the regular net meeting time and frequency
- B. Ensure that all stations checking into the net are properly licensed for operation on the net frequency
- C. Call the net to order and direct communications between stations checking in
- D. All these choices are correct

**T2C07**

**Which of the following is standard practice when you participate in a net?**

- A. When first responding to the net control station, transmit your call sign, name, and address as in the FCC database
- B. Record the time of each of your transmissions
- C. Unless you are reporting an emergency, transmit only when directed by the net control station
- D. All these choices are correct

**T2C05**

**What does the term “traffic” refer to in net operation?**

- A. Messages exchanged by net stations
- B. The number of stations checking in and out of a net
- C. Operation by mobile or portable stations
- D. Requests to activate the net by a served agency

**T2C08**

**Which of the following is a characteristic of good traffic handling?**

- A. Passing messages exactly as received
- B. Making decisions as to whether messages are worthy of relay or delivery
- C. Ensuring that any newsworthy messages are relayed to the news media
- D. All of these choices are correct

**T2C10**

**What information is contained in the preamble of a formal traffic message?**

- A. The email address of the originating station
- B. The address of the intended recipient
- C. The telephone number of the addressee
- D. The information needed to track the message

**T2C11**

**What is meant by “check” in a radiogram header?**

- A. The number of words or word equivalents in the text portion of the message
- B. The call sign of the originating station
- C. A list of stations that have relayed the message
- D. A box on the message form that indicates that the message was received and/or relayed

# **Emergencies**

**Handle the Emergency**

**Any Way You Can**

**Life or Property Loss**

**Any Frequency**

**Any Mode of Communication**

**Get Location and Nature**

**Use Phonetic Alphabet**

**B,D,V Sound similar**

**Brovo Delta Victor**

**FCC May Restrict Operations**

**President's War Emergency  
Powers**

### T2C03

**What technique is used to ensure that voice messages containing unusual words are received correctly?**

- A. Send the words by voice and Morse code
- B. Speak very loudly into the microphone
- C. Spell the words using a standard phonetic alphabet
- D. All of these choices are correct

## EMERGENCY COMM

- **Has top priority**
  - Can use any frequency
- **Message types**
  - Emergency - safety of human life
    - Start with Priority or Emergency
  - Health & welfare - person's well-being
  - SOS for CW
  - Mayday for phone
  - Break and your call on a repeater
- **FCC can declare emergency comm**
  - Special conditions and rules
- **Be prepared**
  - Working HT
    - Programmed to the local repeater
    - Extra charged battery
    - AA cell battery case
  - Dipole for HF
  - Hand tools
  - Food & water



# Emergency Comm operation

- **May use any Frequency**
- **Keep Personal Data Secure**
- **Keep Comm to a Minimum**
  - About 25 words
- **Tactical Call Sign**
- **Use Standard Message Format**
  - Name of Originator
  - Tracking Info
  - Message Tracking (Preamble)
  - Word Count (Check)
  - Use phonetics to spell words
- **Alternate Power Source**
  - Battery
  - Generator
  - Car Battery
  - Solar Panels (Sun Required)

# Emergencies

## Use Any Frequency Provide All Help You Can

---

### T2C09

**Are amateur station control operators ever permitted to operate outside the frequency privileges of their license class?**

- A. No
- B. Yes, but only when part of a FEMA emergency plan
- C. Yes, but only when part of a RACES emergency plan
- D. Yes, but only if necessary in situations involving the immediate safety of human life or protection of property

### T1A03 [97.119(b)(2)]

**What do the FCC rules state regarding the use of a phonetic alphabet for station identification in the Amateur Radio Service?**

- A. It is required when transmitting emergency messages
- B. It is encouraged
- C. It is required when in contact with foreign stations
- D. All these choices are correct

# Antennas

## The Perfect Antenna

Works On All Frequencies  
Matches the TX Perfectly  $50 \Omega$   
Receives Very Weak Signals  
Put RF Energy Where You Want It  
Give You 30 dB Gain or More  
Has the Perfect Ground System  
Does Not Radiate Any Harmonics  
Does Not Show On Your Roof  
Does Not Cost Anything

## And Now for Reality

# ANTENNA LENGTH

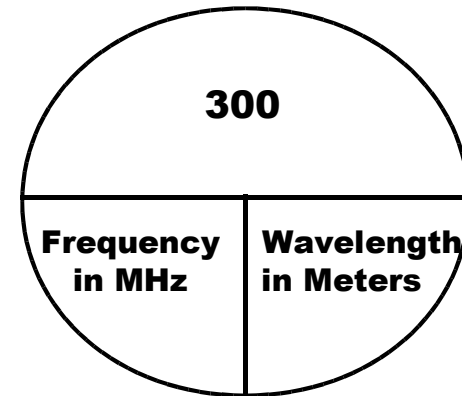

**Frequency x Wavelength =  
300,000,000 meters per second  
(Speed of Light)**

---

### T3B04

**What is the velocity of a radio wave traveling through free space?**

- A. Speed of light
- B. Speed of sound
- C. Speed inversely proportional to its wavelength
- D. Speed that increases as the frequency increases

T3B05

What is the relationship between wavelength and frequency?

- A. Wavelength gets longer as frequency increases
- B. Wavelength gets shorter as frequency increases
- C. Wavelength and frequency are unrelated
- D. Wavelength and frequency increase as path length increases

T3B06

What is the formula for converting frequency to approximate wavelength in meters?

- A. Wavelength in meters equals frequency in hertz multiplied by 300
- B. Wavelength in meters equals frequency in hertz divided by 300
- C. Wavelength in meters equals frequency in megahertz divided by 300
- D. Wavelength in meters equals 300 divided by frequency in megahertz

T3B07

In addition to frequency, which of the following is used to identify amateur radio bands?

- A. The approximate wavelength in meters
- B. Traditional letter/number designators
- C. Channel numbers
- D. All these choices are correct

**T3B11**

**What is the approximate velocity of a radio wave in free space?**

- A. 150,000 meters per second
- B. 300,000,000 meters per second
- C. 300,000,000 miles per hour
- D. 150,000 miles per hour

*Wavelength = 300,000,000 / Frequency*

*300,000,000 / 146,000,000 = 2.05 Meters*

*½ Wave = 1.02 Meters*

*39.4 in per meter = 40 in*

*If 36 in per meter = 36.7 in (This fudge factor works)*

*¼ Wave = 18.4*

**T9A08**

**What is the approximate length, in inches, of a quarter-wavelength vertical antenna for 146 MHz?**

- A. 112
- B. 50
- C. 19
- D. 12

**T9A09**

**What is the approximate length, in inches, of a half-wavelength 6 meter dipole antenna?**

- A. 6
- B. 50
- C. 112
- D. 236

## VHF-UHF Antennas

1/4 wave antenna for 146 MHz is 19”

5/8 wave

- “Gain”
- Lower Radiation angle
- Omni-directional

### J Pole

---

T9A12

What is an advantage of a 5/8 wavelength whip antenna for VHF or UHF mobile service?

- A. It has more gain than a 1/4-wavelength antenna
- B. It radiates at a very high angle
- C. It eliminates distortion caused by reflected signals
- D. It has 10 times the power gain of a 1/4 wavelength whip

## NVIS Antenna

Near Vertical Incidence Skywave

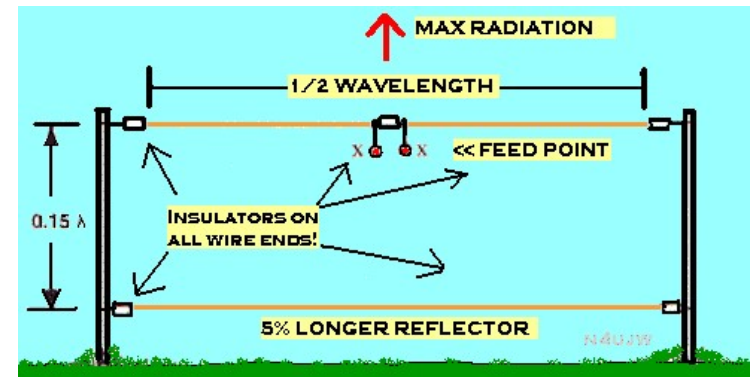

Used for Short Distance HF Contacts  
Sure Looks Like a Yagi Pointed Up

# The Dipole

## Simple Antenna

Half Wavelength Long

Horizontally Polarized

## Height Above Ground Changes

Feed-point impedance

Decreases as the antenna  
approaches the ground

Increases as the feed-point  
is widened

.1  $\lambda$  NVIS antenna

High Vertical Angle

Short Range HF Daytime

.5  $\lambda$  Dipole

Low Angle Radiation

Good for 40 meter Skip

Directional

“Figure-Eight”

Lobes at 90 Degrees

## Easy to install

## Reference Antenna

KN6FW

153

### T9A03

**Which of the following describes a simple dipole oriented parallel to the Earth's surface?**

- A. A ground-wave antenna
- B. A horizontally polarized antenna
- C. A rhombic antenna
- D. A vertically polarized antenna

### T9A10

**In which direction does a half-wave dipole antenna radiate the strongest signal?**

- A. Equally in all directions
- B. Off the ends of the antenna
- C. In the direction of the feed line
- D. Broadside to the antenna

### T9A05

**Which of the following increases the resonant frequency of a dipole antenna?**

- A. Lengthen it
- B. Insert coils in series with radiating wires
- C. Shorten it
- D. Add capacitive loading to the ends of the radiating wires

KN6FW

154

# HF Antennas

## Horizontal

Dipole

Lower Ground Reflection Losses  
Below  $\frac{1}{2}$  wavelength omnidirectional

## Vertical

Mounts in a Small Space

Requires a Ground  
Radials on the Ground  
Or Buried a few inches

## Multiband

Works very well on harmonics  
Traps in elements (tuned circuits)

# HF Antenna Safety

**Long Wire Antennas may allow  
RF in the Shack**

**Ground mounted Antennas  
Need to be protected from  
People**

**Working on antenna  
Tx Should be OFF**

# Ground Plane Antenna

Very Simple Antenna

Easy to Make

Female PL 259

Coat Hanger

Sloping Radials Downward

Increase Impedance to  $50 \Omega$

# Beverage Antenna

Receiving Antenna

**High Losses TX**

**Long Wire Type**

Highly Directional

That's Harold Beverage

Not BUDweiser Beverage

# GAIN / BEAM ANTENNAS

- **Gain antennas**
    - Compress power in one direction
    - Lower the angle of radiation
    - Can Null Out Interfering Stations
  - **Cross polarized antennas**
    - **About 30 dB loss**
- 

**T3A04**

**What happens when antennas at opposite ends of a VHF or UHF line of sight radio link are not using the same polarization?**

- A. The modulation sidebands might become inverted
- B. Signals could be significantly weaker
- C. Signals have an echo effect on voices
- D. Nothing significant will happen

# YAGI ANTENNA

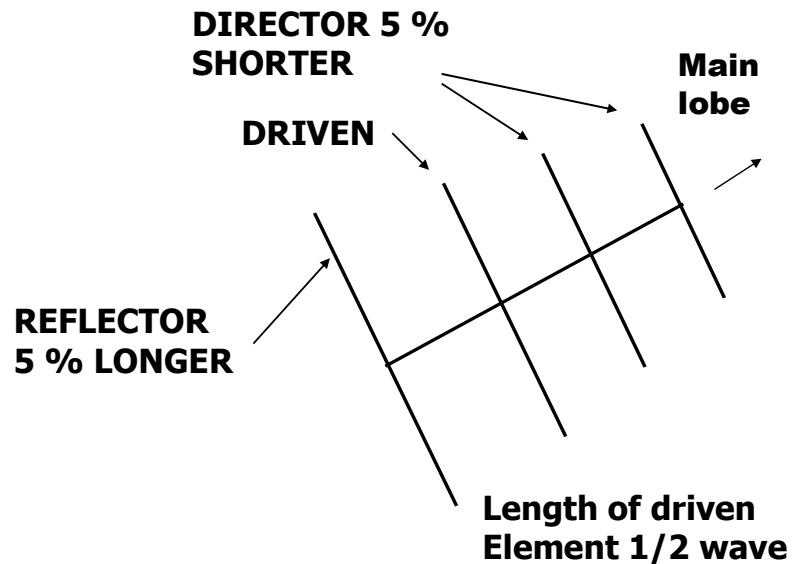

# Yagi

- Reflector (back end - longer)
- Driven element (next to reflector - 1/2 wavelength)
- Director(s) (front - shorter)
- Gain determined by
  - Boom length
  - Number of directors (elements)
- Bandwidth
  - Larger element diameters
- Can be made for multibands (Traps)
  - One feed line
  - Bad for harmonics
- Front to Back Ratio
  - Design for low response to the rear
  - Position of Elements
- 3 Element Yagi Has a Gain of About 6 dB or 9 dBi
- A Dipole Has 2.15 dBi "Gain"



**T9A01**

**What is a beam antenna?**

- A. An antenna built from aluminum I-beams
- B. An omnidirectional antenna invented by Clarence Beam
- C. An antenna that concentrates signals in one direction
- D. An antenna that reverses the phase of received signals

**T9A11**

**What is the gain of an antenna?**

- A. The additional power that is added to the transmitter power
- B. The additional power that is lost in the antenna when transmitting on a higher frequency
- C. The increase in signal strength in a specified direction compared to a reference antenna
- D. The increase in impedance on receive or transmit compared to a reference antenna

**T9A06**

**Which of the following types of antenna offers the greatest gain?**

- A. 5/8 wave vertical
- B. Isotropic
- C. J pole
- D. Yagi

# QUAD - DELTA

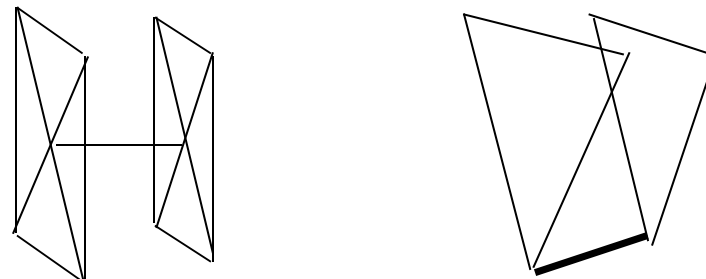

**1 Wavelength Around the Loop**

For the driven element

5% larger for reflector

**2 Element Quad Gain about  
Equal a 3 Element Yagi**

**Feed-point – Polarization**

Bottom Center Horizontal

Side Center Vertical

# LOADED ANTENNAS

## Make them seem longer

**Capacitance hat**

**Coil of wire in the antenna**

Usually at the Base

Makes the antenna “longer”

Rubber duck

HF antennas

Not as good as full length

Reduces bandwidth

---

**T9A02**

**Which of the following describes a type of antenna loading?**

- A. Electrically lengthening by inserting inductors in radiating elements
- B. Inserting a resistor in the radiating portion of the antenna to make it resonant
- C. Installing a spring in the base of a mobile vertical antenna to make it more flexible
- D. Strengthening the radiating elements of a beam antenna to better resist wind damage

**T9A04**

**What is a disadvantage of the short, flexible antenna supplied with most handheld radio transceivers, compared to a full-sized quarter-wave antenna?**

- A. It has low efficiency
- B. It transmits only circularly polarized signals
- C. It is mechanically fragile
- D. All these choices are correct

## WHY COAX?

### It is shielded

- No radiation
- Can be run next to metal

### It can be run under ground

- Few Special Installation Requirements

### Cut off any excess

- Length = loss
- Loss increases with frequency

### If coax gets hot replace it

### Keep SWR low

- Loss in coax both ways

### Most Coax is Black – UV

### Failure from Moisture or UV

### Transmitting Coax is 50 Ohm

## COAX

- **RG 58**
  - 50 ohm 3dB loss per 100 ft @ 100 MHz
- **RG 59**
  - 72 ohm 3dB loss per 100 ft @ 100 MHz
- **RG 8**
  - 50 ohm 2.5dB loss per 100 ft @ 100 MHz
- **RG 213**
  - 50 ohm 2.5 dB loss per 100 ft @ 100 MHz
- **RG 174**
  - 50 ohm 11 dB loss per 100 ft @ 100 MHz
- **9913**
  - 50 ohm 1.3 dB loss per 100 ft @ 100 MHz
  - Air core = water pipe
- **Heliax**
  - 50 ohm .2 dB loss per 100 ft @ 100 MHz
- **Hard line**
  - Pipe inside pipe
  - Extremely low loss

**T9B05**

**What happens as the frequency of a signal in coaxial cable is increased?**

- A. The characteristic impedance decreases
- B. The loss decreases
- C. The characteristic impedance increases
- D. The loss increases

**T9B02**

**What is the most common impedance of coaxial cables used in amateur radio?**

- A. 8 ohms
- B. 50 ohms
- C. 600 ohms
- D. 12 ohms

**T7C09**

**Which of the following causes failure of coaxial cables?**

- A. Moisture contamination
- B. Solder flux contamination
- C. Rapid fluctuation in transmitter output power
- D. Operation at 100% duty cycle for an extended period

**T7C07**

**What happens to power lost in a feed line?**

- A. It increases the SWR
- B. It is radiated as harmonics
- C. It is converted into heat
- D. It distorts the signal

**T9B03**

**Why is coaxial cable the most common feed line for amateur radio antenna systems?**

- A. It is easy to use and requires few special installation considerations
- B. It has less loss than any other type of feed line
- C. It can handle more power than any other type of feed line
- D. It is less expensive than any other type of feed line

**T9B08**

**Which of the following is a source of loss in coaxial feed line?**

- A. Water intrusion into coaxial connectors
- B. High SWR
- C. Multiple connectors in the line
- D. All these choices are correct

**T7C10**

**Why should the outer jacket of coaxial cable be resistant to ultraviolet light?**

- A. Ultraviolet resistant jackets prevent harmonic radiation
- B. Ultraviolet light can increase losses in the cable's jacket
- C. Ultraviolet and RF signals can mix, causing interference
- D. Ultraviolet light can damage the jacket and allow water to enter the cable

**T7C11**

**What is a disadvantage of air core coaxial cable when compared to foam or solid dielectric types?**

- A. It has more loss per foot
- B. It cannot be used for VHF or UHF antennas
- C. It requires special techniques to prevent water absorption
- D. It cannot be used at below freezing temperatures

**T9B10**

**What is the electrical difference between RG-58 and RG-213 coaxial cable?**

- A. There is no significant difference between the two types
- B. RG-58 cable has two shields
- C. RG-213 cable has less loss at a given frequency
- D. RG-58 cable can handle higher power levels

**T9B11**

**Which of the following types of feed line has the lowest loss at VHF and UHF?**

- A. 50-ohm flexible coax
- B. Multi-conductor unbalanced cable
- C. Air-insulated hard line
- D. 75-ohm flexible coax

**T9B01**

**What is a benefit of low SWR?**

- A. Reduced television interference
- B. Reduced signal loss
- C. Less antenna wear
- D. All these choices are correct

# SWR

## (STANDING WAVE RATIO)

- **SWR**
  - A ratio of the forward power to the antenna to the reflected power returned from the antenna
  - Can be read as voltage with a slotted line
- Cause
  - Mismatch of Impedance
  - $50 \Omega$  to  $100 \Omega$  = SWR of 2:1
- **Directional Wattmeter**
  - 50 Ohms typical
  - $SWR = \frac{\text{Forward} + \text{Reflected}}{\text{Forward} - \text{Reflected}}$
- **SWR meter**
  - Do not use a HF SWR meter at VHF
  - Must meet power of transmitter
  - Measures SWR directly
- **Connected**
  - Between transmitter and transmission line
- **Readings**
  - 1:1 Very good 1.5:1 Good 4:1 Bad
- **Erratic Readings**
  - Something is Loose

### T9B12

#### What is standing wave ratio (SWR)?

- A. A measure of how well a load is matched to a transmission line
- B. The ratio of amplifier power output to input
- C. The transmitter efficiency ratio
- D. An indication of the quality of your station's ground connection

### T7C04

#### What reading on an SWR meter indicates a perfect impedance match between the antenna and the feed line?

- A. 50:50
- B. Zero
- C. 1:1
- D. Full Scale

### T7C08

#### Which instrument can be used to determine SWR?

- A. Voltmeter
- B. Ohmmeter
- C. Iambic pentameter
- D. Directional wattmeter

### T4A02

#### Which of the following should be considered when selecting an accessory SWR meter?

- A. The frequency and power level at which the measurements will be made
- B. The distance that the meter will be located from the antenna
- C. The types of modulation being used at the station
- D. All these choices are correct

**T4A05**

**Where should an RF power meter be installed?**

- A. In the feed line, between the transmitter and antenna
- B. At the power supply output
- C. In parallel with the push-to-talk line and the antenna
- D. In the power supply cable, as close as possible to the radio

**T7C06**

**What does an SWR reading of 4:1 indicate?**

- A. Loss of -4 dB
- B. Good impedance match
- C. Gain of +4 dB
- D. Impedance mismatch

**T9B09**

**What can cause erratic changes in SWR readings?**

- A. The transmitter is being modulated
- B. A loose connection in an antenna or a feed line
- C. The transmitter is being over-modulated
- D. Interference from other stations is distorting your signal

# ANTENNA TUNER

**Makes a correct match to any antenna**

**Looks like 50 ohms to transmitter**

**Newer radio shut-down if there is a bad match to save the output**

---

**T7C05**

**Why do most solid-state transmitters reduce output power as SWR increases beyond a certain level?**

- A. To protect the output amplifier transistors
- B. To comply with FCC rules on spectral purity
- C. Because power supplies cannot supply enough current at high SWR
- D. To lower the SWR on the transmission line

**T9B04**

**What is the major function of an antenna tuner (antenna coupler)?**

- A. It matches the antenna system impedance to the transceiver's output impedance
- B. It helps a receiver automatically tune in weak stations
- C. It allows an antenna to be used on both transmit and receive
- D. It automatically selects the proper antenna for the frequency band being used

# **BAND EDGE**

**STAY AWAY FROM BAND EDGE  
MODULATION USES BANDWIDTH  
TRANSMITTER**

- **Frequency Calibration**
  - **Stability**
- 

T1B09 [97.101(a), 97.301(a-e)]

Why should you not set your transmit frequency to be exactly at the edge of an amateur band or sub-band?

- A. To allow for calibration error in the transmitter frequency display
- B. So that modulation sidebands do not extend beyond the band edge
- C. To allow for transmitter frequency drift
- D. All of these choices are correct



# BANDWIDTH

## **CW**

**Very low About 100 Hz  
Depends on Sending Speed**

## **RTTY**

**Low About 500 Hz**

## **SSB**

**About 3 kHz  
2.8 kHz on 60 Meters**

## **AM**

**About 6 kHz**

## **FM**

**About 15 to 20 kHz**

## **TV**

**About 6 MHz**

---

### **T8A05**

**Which of the following types of signal has the narrowest bandwidth?**

- A. FM voice
- B. SSB voice
- C. CW
- D. Slow-scan TV

### **T8A11**

**What is the approximate maximum bandwidth required to transmit a CW signal?**

- A. 2.4 kHz
- B. 150 Hz
- C. 1000 Hz
- D. 15 kHz

### **T8A08**

**What is the approximate bandwidth of a typical single sideband (SSB) voice signal?**

- A. 1 kHz
- B. 3 kHz
- C. 6 kHz
- D. 15 kHz

### **T8A09**

**What is the approximate bandwidth of a VHF repeater FM phone signal?**

- A. Less than 500 Hz
- B. About 150 kHz
- C. Between 10 and 15 kHz
- D. Between 50 and 125 kHz

### **T8A10**

**What is the approximate bandwidth of AM fast-scan TV transmissions?**

- A. More than 10 MHz
- B. About 6 MHz
- C. About 3 MHz
- D. About 1 MHz

**T8A07**

**What is a characteristic of single sideband (SSB) compared to FM?**

- A. SSB signals are easier to tune in correctly
- B. SSB signals are less susceptible to interference
- C. SSB signals have narrower bandwidth
- D. All these choices are correct

# RADIO / BANDWIDTH

## Radio bandwidth filters

- Match filter to signal
  - Reduce interference
  - CW about 500 Hz
  - SSB about 3 kHz
  - FM about 15 kHz
- 

**T4B08**

**What is the advantage of having multiple receive bandwidth choices on a multimode transceiver?**

- A. Permits monitoring several modes at once
- B. Permits noise or interference reduction by selecting a bandwidth matching the mode
- C. Increases the number of frequencies that can be stored in memory
- D. Increases the amount of offset between receive and transmit frequencies

**T4B10**

**Which of the following receiver filter bandwidths provides the best signal-to-noise ratio for SSB reception?**

- A. 500 Hz
- B. 1000 Hz
- C. 2400 Hz
- D. 5000 Hz

## **TECH + PRIVILEGES**

### **CW Only**

*200 Watts MAX POWER on HF*

80 METERS      3.675 MHz to 3.725 MHz  
                         3675 kHz to 3725 kHz

40 METERS      7.100 MHz to 7.150 MHz  
15 METERS      21.100 MHz to 21.200 MHz

### **CW + RTTY + Data**

10 METERS      28.100 MHz to 28.300 MHz

### **CW + SSB**

10 METERS      28.300 MHz to 28.500 MHz

### **FULL PRIVILEGES**

*Almost all modes 1500 Watts*

\*6 METERS            50 MHz to 54 MHz  
\*2 METERS            144 MHz to 148 MHz  
\*1.25 METERS        222 MHz to 225 MHz  
70 CENTIMETERS    420 MHz to 450 MHz  
33 CENTIMETERS    902 MHz to 928 MHz  
23 CENTIMETERS    1240 MHz to 1300 MHz  
13 CENTIMETERS    2300 MHz to 2310 MHz  
                         and            2390 MHz to 2450 MHz

\* CW Sub Band

## FREQUENCY times WAVELENGTH EQUALS 300,000,000

$$\frac{300,000,000}{10 \text{ METERS}} = 30 \text{ MHz}$$

10 METERS = 28.000 MHz to 29.7 MHz

10 METER PHONE 28.300 MHz to 28.500 MHz

### HF HAM Bands

80 METERS = 3.5 MHz

40 METERS = 7.0 MHz

20 METERS = 14.0 MHz no TECH +

15 METERS = 21.0 MHz

10 METERS = 28.0 MHz

### TECH+ Bands

Never start or end with .000

Always near the low end of the band

Always a very small piece of the band

#### T1B01 [97.301 (e)]

Which of the following frequency ranges are available for phone operation by Technician licensees?

- A. 28.050 MHz to 28.150 MHz
- B. 28.100 MHz to 28.300 MHz
- C. 28.300 MHz to 28.500 MHz
- D. 28.500 MHz to 28.600 MHz

#### T1B06 [97.301(e), 97.305]

On which HF bands does a Technician class operator have phone privileges?

- A. None
- B. 10 meter band only
- C. 80 meter, 40 meter, 15 meter and 10 meter bands
- D. 30 meter band only

#### T1B07 [97.305(a), (c)]

Which of the following VHF/UHF frequency ranges are limited to CW only?

- A. 50.0 MHz to 50.1 MHz and 144.0 MHz to 144.1 MHz
- B. 219 MHz to 220 MHz and 420.0 MHz to 420.1 MHz
- C. 902.0 MHz to 902.1 MHz
- D. All of these choices are correct

#### T1B10 [97.305(c)]

Where may SSB phone be used in amateur bands above 50 MHz?

- A. Only in sub-bands allocated to General class or higher licensees
- B. Only on repeaters
- C. In at least some portion of all these bands
- D. On any band as long as power is limited to 25 watts

## **FREQUENCY times WAVELENGTH EQUALS 300,000,000**

---

**T1B03 [97.301(a)]**

**Which frequency is within the 6 meter amateur band?**

- A. 49.00 MHz
- B. 52.525 MHz
- C. 28.50 MHz
- D. 222.15 MHz

**T1B04 [97.301(a)]**

**Which amateur band includes 146.52 MHz?**

- A. 6 meters
- B. 20 meters
- C. 70 centimeters
- D. 2 meters

## **Good Operating**

**Monitor Before Transmitting**

**Follow the Band Plan**

**Stay Within Your Privileges**

**Say Your Call to Break Into a Contact**

---

**T2A10**

**What is a band plan, beyond the privileges established by the FCC?**

- A. A voluntary guideline for using different modes or activities within an amateur band
- B. A list of operating schedules
- C. A list of available net frequencies
- D. A plan devised by a club to indicate frequency band usage

**T2A12**

**What should you do before calling CQ?**

- A. Listen first to be sure that no one else is using the frequency
- B. Ask if the frequency is in use
- C. Make sure you are authorized to use that frequency
- D. All these choices are correct

# **Third Party Someone not a Ham**

**Hams with Revoked license may not  
be a Third Party**

**Third Party Agreements required  
with Foreign Countries**

**Must ID with Both Calls in English  
Messages of a Personal Nature or  
HAM BS**

**Emergencies No Rules**

**T1F07 [97.115(a)(2)]**

**Which of the following restrictions apply when a non-licensed person is allowed to speak to a foreign station using a station under the control of a Technician class control operator?**

- A. The person must be a U.S. citizen
- B. The foreign station must be one with which the U.S. has a third-party agreement
- C. The licensed control operator must do the station identification
- D. All of these choices are correct

**T1F08 [97.3(a)(47)]**

**What is the definition of third party communications?**

- A. A message from a control operator to another amateur station control operator on behalf of another person
- B. Amateur radio communications where three stations are in communications with one another
- C. Operation when the transmitting equipment is licensed to a person other than the control operator
- D. Temporary authorization for an unlicensed person to transmit on the amateur bands for technical experiments

## Single Sideband Usage

40 Meters and Below LSB

Every else Upper Sideband

**Equal Access to  
Frequencies  
This is NOT true!**

## HAM Etiquette

Ask if Frequency is in Use

Other Signals Interfering Move

DX if Long Distance

---

**T2B08**

Which of the following applies when two stations transmitting on the same frequency interfere with each other?

- A. The stations should negotiate continued use of the frequency
- B. Both stations should choose another frequency to avoid conflict
- C. Interference is inevitable, so no action is required
- D. Use subaudible tones so both stations can share the frequency

# Mixer

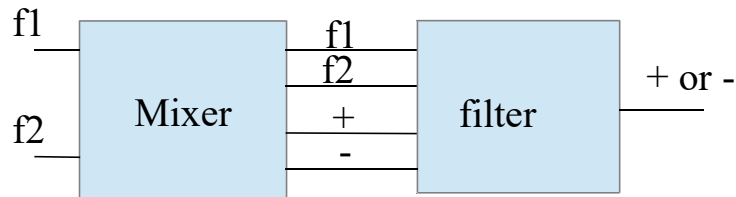

- **Superhetrodyne receiver**
  - Standard radio
- **Transverter**
  - Converts lower frequency TX to higher frequency TX

## T7A03

Which of the following is used to convert a radio signal from one frequency to another?

- A. Phase splitter
- B. Mixer
- C. Inverter
- D. Amplifier

## T7A06

What device converts the RF input and output of a transceiver to another band?

- A. High-pass filter
- B. Low-pass filter
- C. Transverter
- D. Phase converter



## CW OPERATION

- Uses International Morse
- SOS = Emergency
- CQ = Calling any station  
(used on phone too)
  - Send “CQ” 3 times then “DE” then your call 3 times
    - Don’t send faster than you can receive
  - Answer “CQ”
    - Send the other station’s call 2 times then “DE” then your call 2 times
  - Use any thing want to key the TX

---

**T8D09**

**What is CW?**

- A. A type of electromagnetic propagation
- B. A digital mode used primarily on 2 meter FM
- C. A technique for coil winding
- D. Another name for a Morse code transmission

## CW Q Signals

**What do all those Q - - mean**

- QRL – Frequency in use?
- QRM** – Man made noise
- QRN – I am troubled by static
- QRP – Low power
- QRS - Send slower
- QRV - Ready to receive message
- QSK - Full break-in
- QSL - Acknowledge receipt
- QSY** – Change frequency

---

**T2B10**

**Which Q signal indicates that you are receiving interference from other stations?**

- A. QRM
- B. QRN
- C. QTH
- D. QSB

**T2B11**

Which Q signal indicates that you are changing frequency?

- A. QRU
- B. QSY
- C. QSL
- D. QRZ

## Keying the TX

**Delay from Rx to Tx**

**Time for transition to TX**

**To Keep TX out of RX**

**Use anything you want**

Manual key

Bug

Electronic key

Computer

Two wires

---

**T4A12**

**What is an electronic keyer?**

- A. A device for switching antennas from transmit to receive
- B. A device for voice activated switching from receive to transmit
- C. A device that assists in manual sending of Morse code
- D. An interlock to prevent unauthorized use of a radio

## RTTY - Data

- **Tech Only on 10 Meters and above**
- **RTTY**
  - Baudot – 5 bit code
  - 170 Hz shift on HF
  - Audio frequency shift keying
    - Use LSB
- **Data**
  - 300 baud max below 28 MHz
  - 1200 baud max 10 meters
  - 19.6 Kilobaud on 6 – 2 meters
  - 20 kHz bandwidth 6 – 2 meters
  - 56 Kilobaud on 1.25 meters – 70 cm
  - High symbol rate = More Bandwidth

197

## DATA OPERATION

- **Radio connections**
  - Frequency shift
  - Audio in – out
  - PTT
- **RTTY**
  - Radio teletype
  - Computer or teletype required
  - Frequency shift on HF
  - Modems on VHF/UHF
- **Packet**
  - Computer
  - TNC terminal node controller
  - Sound card
  - Forwarding 219-220 MHz<sup>198</sup>

KN6FW

#### **T4A04**

**How are the transceiver audio input and output connected in a station configured to operate using FT8?**

- A. To a computer running a terminal program and connected to a terminal node controller unit
- B. To the audio input and output of a computer running WSJT-X software
- C. To an FT8 conversion unit, a keyboard, and a computer monitor
- D. To a computer connected to the FT8converter.com website

#### **T4A06**

**What signals are used in a computer-radio interface for digital mode operation?**

- A. Receive and transmit mode, status, and location
- B. Antenna and RF power
- C. Receive audio, transmit audio, and push-to-talk (PTT)
- D. NMEA GPS location and DC power

#### **T4A07**

**Which of the following connections is made between a computer and a transceiver to use computer software when operating digital modes?**

- A. Computer "line out" to transceiver push-to-talk
- B. Computer "line in" to transceiver push-to-talk
- C. Computer "line in" to transceiver speaker connector
- D. Computer "line out" to transceiver speaker connector

## **Frequencies for Data**

- **219-220 MHz Forwarding**

---

#### **T1B05 [97.305(c)]**

**How may amateurs use the 219 to 220 MHz segment of 1.25 meter band?**

- A. Spread spectrum only
- B. Fast-scan television only
- C. Emergency traffic only
- D. Fixed digital message forwarding systems only

## Other Data Modes

- **Packet – Old after RTTY**
  - Retransmit for data correction  
ARQ
  - Formatted Message
  - Header has address
  - Check sum
  - FM modulation on VHF
- **PSK31**
  - Variable bits per character
    - Varicode
  - 31 is the approximate symbol rate
  - Upper Case Letters generate Longer Character

201

### T8A02

**What type of modulation is most commonly used for VHF packet radio transmissions?**

- A. FM or PM
- B. SSB
- C. AM
- D. PSK

### T8D08

**Which of the following is included in packet radio transmissions?**

- A. A check sum that permits error detection
- B. A header that contains the call sign of the station to which the information is being sent
- C. Automatic repeat request in case of error
- D. All of these choices are correct

### T8D11

**What is an ARQ transmission system?**

- A. A special transmission format limited to video signals
- B. A system used to encrypt command signals to an amateur radio satellite
- C. A digital scheme whereby the receiving station detects errors and sends a request to the sending station to retransmit the information
- D. A method of compressing data using autonomous reiterative Q codes prior to final encoding

202

## Pactor

- **Speed Changes with Communication Quality**
- **If Quality Drops Too Far The Connection may Drop**
- **ACK NAK Retransmit on Errors**
- **Master Slave (Just 2)**
- **Can Be Monitored**
- **Bandwidth at max 2300 Hz**
- **Characters 2 to 15 Bits**
  - Most used Small (E)
  - Uncommon Large (Z)

203

## JT65 and JT9

- **Slow baud rate**
  - **Weak signal**
  - **Multi Tone Signal (AFSK)**
  - **Uses USB**
- 

T8D01

Which of the following is a digital communications mode?

- A. Packet radio
- B. IEEE 802.11
- C. FT8
- D. All of these choices are correct

204

# Broadband-Hamnet

## Modified Wi-Fi gear

- Linksys WRT54G\_
- 2.4 GHz
- Short range

## Digital Network

- Like internet
- Fault Tolerant
- Mesh Network

---

### T8D12

**Which of the following best describes an amateur radio mesh network?**

- A. An amateur-radio-based data network using commercial Wi-Fi gear with modified firmware
- B. A wide-bandwidth digital voice mode employing DRM protocols
- C. A satellite communications network using modified commercial satellite TV hardware
- D. An internet linking protocol used to network repeaters

205

# FT8

## HF Digital Mode

**Works below noise**

**8 Frequency Shift Keying**

**Requires Accurate Time**

**15 Second Burst**

---

### T8D13

**What is FT8?**

- A. A wideband FM voice mode
- B. A digital mode capable of low signal-to-noise operation
- C. An eight channel multiplex mode for FM repeaters
- D. A digital slow-scan TV mode with forward error correction and automatic color compensation

206

## PSK - FSK - AFSK

- **FSK Frequency Shift Keying**
- **PSK Phase Shift Keying**
  - Change TX frequency
- **AFSK Audio FSK**
  - Tones into Radio Input
  - One Tone for Mark
  - A different Tone for Space
- **Mark – Space**
  - Old Terms for On – OFF
  - Mark = On
  - Space = Off

---

**T8D06**

**What does the abbreviation "PSK" mean?**

- A. Pulse Shift Keying
- B. Phase Shift Keying
- C. Packet Short Keying
- D. Phased Slide Keying

207

## Codes

- **Baudot**
  - Old 5 Bit Code used on First TTY
  - 5 bits only 32 possible Characters
  - Letters – Figures Shift
- **ASCII**
  - 8 Bit Code including Parity
    - Parity Error Checking

208



## Poor Communication

- Very weak signal
- Noise
- Interference
- Multi-path

### All can cause:

- 1 Frequent retries or timeouts
  - 2 Long pauses in message transmission
  - 3 Failure to establish a connection between stations
- 

#### T3A10

What effect does multi-path propagation have on data transmissions?

- A. Transmission rates can be increased by a factor equal to the number of separate paths observed
- B. Transmission rates must be decreased by a factor equal to the number of separate paths observed
- C. No significant changes will occur if the signals are transmitted using FM
- D. Error rates are likely to increase

209

## Thing Go Wrong

- **ALC Automatic Level Control**
  - Not Set properly
    - Distorts the signal
    - Can cause spurious emissions
- **Baud Rate Mismatch**
  - You Get Junk
- **Mark – Space Reversed**
  - You Get Junk
- **Wrong Side Band**
  - You Get Junk
- **RF Signal Gets into Audio**
  - VOX Does Not Unkey
  - Distorted signal
  - Bad communication (Time-outs)
- **Packet Containing Errors**
  - Requests the Packet be Retransmitted
  - Forward Error Correction
    - Transmitting redundant information

210

# FCC Rules / DATA

- **Automatic Control**
  - Connect to the Internet
  - Called Automatically Controlled Digital
  - No operator
- **Automatic to Automatic**
  - 1.25 Meters and above
  - 2 Meters & HF some Band segments
- **No Money**
- **Third Party (Standard Rules)**

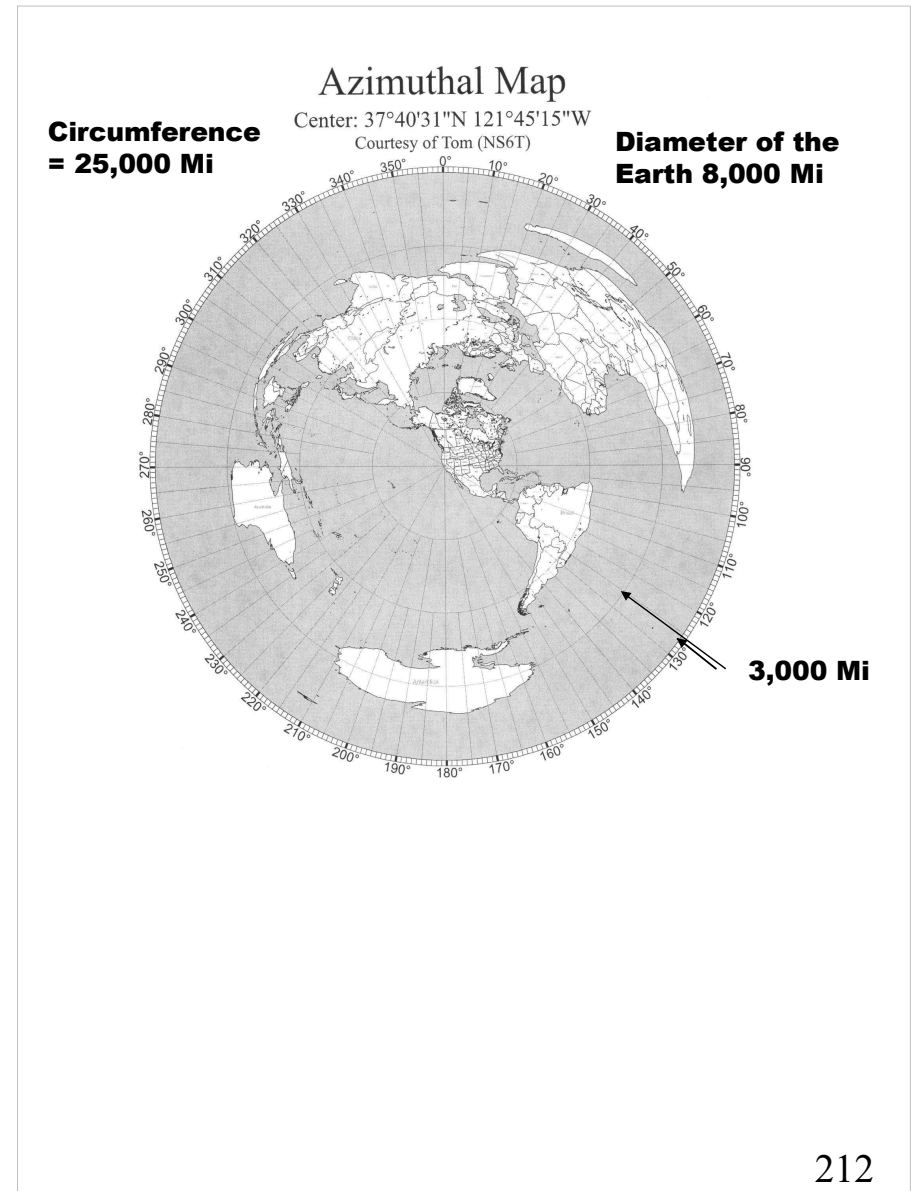

# HF operation 1

- **Pointing your HF antenna**
  - Azimuthal Projection Map
    - World map centered at your station
- **CQ**
  - Any station
  - Answer with stations call then yours
- **CQ DX**
  - Contact outside country
- **QRP**
  - Low power ( less than 5W )
- **HF Mobile**
  - Ant Limit
  - Ground?

## T2A05

**How should you respond to a station calling CQ?**

- A. Transmit "CQ" followed by the other station's call sign
- B. Transmit your call sign followed by the other station's call sign
- C. Transmit the other station's call sign followed by your call sign
- D. Transmit a signal report followed by your call sign

## T2A08

**What is the meaning of the procedural signal "CQ"?**

- A. Call on the quarter hour
- B. Test transmission, no reply expected
- C. Only the called station should transmit
- D. Calling any station

## HF operation 2

- **SSB Adjustments**
  - Speech processor
    - Improves signal intelligibility
    - increases average power
  - Automatic Level Control – ALC
    - Microphone gain
  - Poorly adjusted
    - Flat-topping
    - Distorted speech
    - Splatter
    - Background sounds
- **Neutralization**
  - Circuit positive feedback
    - Causes self oscillation
  - Corrected with negative feedback

**T4B01**

**What is the effect of excessive microphone gain on SSB transmissions?**

- A. Frequency instability
- B. Distorted transmitted audio
- C. Increased SWR
- D. All these choices are correct

## HF Radios

- **RIT Receiver Incremental Tuning**
  - Allows you tune RX & not TX
- **Noise Blanker**
  - Reduces ignition type noise
- **RF feedback**
  - Garbled, distorted, or unintelligible

## SSB Transmitter

- A Form of AM
- Uses a Balanced Modulator
  - Produces 2 Side Bands No CXR
  - Filters Remove 1 Side Band
- Once Modulated it can't be multiplied
  - Must be Mixed or Heterodyned

### T4B06

Which of the following controls could be used if the voice pitch of a single-sideband signal seems too high or low?

- A. The AGC or limiter
- B. The bandwidth selection
- C. The tone squelch
- D. The RIT or Clarifier

# Using Your HF Radio

## **Notch Filter**

Block a Signal Interfering

## **CW High – Low Side**

Less Interference

## **Intermediate Frequency (IF) Shift**

Reduce Interference from Close signal

## **Split Mode**

TX on One Frequency

RX on Another

40 Meters Outside the US

## **ALC Automatic Level Control**

Control Modulation

Distortion from Over Drive (Flat Topping)

Excessive Bandwidth

## **Drive to a Power Amplifier**

Over Drive can Damage a Solid State Amp

# Using Your HF Radio 2

## **Dual VFO**

Monitoring of 2 Frequencies

## **Speech Processor**

Fancy ALC

Increases Average Power

## **Attenuator**

Reduce Signal Overload

## **S Meter**

Relative Received Signal Strength

Different on most Radios

## **Antenna Tuner**

Match TX - Antenna Impedance

## **VOX**

Voice Operated Relay (Transmit)

# Handheld HT VHF/UHF

## All Those Keys

- **You will need the manual**
  - Copy it and put it in your car
- **F Key**
  - Selects function normally not used
- **Shift Key**
  - Turns on repeater offset
- **Step function (F Key)**
  - Sets tuning steps (rate)
- **Scan Key**
  - Monitor Lots of Frequencies
- **Microphone Buttons**
  - Push to talk (PTT)
  - Touch tone - Phone patch
  - Up Down – Frequency selection

### T4B05

**What does the scanning function of an FM transceiver do?**

- A. To check incoming signal deviation
- B. To prevent interference to nearby repeaters
- C. To scan through a range of frequencies to check for activity
- D. To check for messages left on a digital bulletin board

### T7A07

**What is the function of a transceiver's PTT input?**

- A. Input for a key used to send CW
- B. Switches transceiver from receive to transmit when grounded
- C. Provides a transmit tuning tone when grounded
- D. Input for a preamplifier tuning tone

# Receiver tech stuff

- **Sensitivity**
  - How weak a signal it can detect
- **Selectivity**
  - How well it can receive one signal
- **Squelch**
  - Muting receiver with no signal
- **Automatic gain control or AGC**
  - Keeps audio relatively constant
- **S meter**
  - Signal strength
  - Not the same on all radios

## T7A01

**Which term describes the ability of a receiver to detect the presence of a signal?**

- A. Linearity
- B. Sensitivity
- C. Selectivity
- D. Total Harmonic Distortion

## T7A04

**Which term describes the ability of a receiver to discriminate between multiple signals?**

- A. Discrimination ratio
- B. Sensitivity
- C. Selectivity
- D. Harmonic distortion

## T2B13

**What is the purpose of a squelch function?**

- A. Reduce a CW transmitter's key clicks
- B. Mute the receiver audio when a signal is not present
- C. Eliminate parasitic oscillations in an RF amplifier
- D. Reduce interference from impulse noise



## Use Your Radio

- **VFO Variable frequency osc**
  - Manual tuning knob – Setup
  - Some radios use keypad
- **Radios have memory**
  - Frequency
  - PL
  - State of radio when stored
- **Squelch**
  - Turns off audio if no signal
- **Automatic Gain Control (AGC)**
  - Keeps audio “the same”
- **Distorted signal**
  - Battery low?
  - Off frequency?
  - Bad Location?

### T4B02

**Which of the following can be used to enter the operating frequency on a modern transceiver?**

- A. The keypad or VFO knob
- B. The CTCSS or DTMF encoder
- C. The Automatic Frequency Control
- D. All of these choices are correct

### T4B03

**How is squelch adjusted so that a weak FM signal can be heard?**

- A. Set the squelch threshold so that receiver output audio is on all the time
- B. Turn up the audio level until it overcomes the squelch threshold
- C. Turn on the anti-squelch function
- D. Enable squelch enhancement

### T4B04

**What is a way to enable quick access to a favorite frequency or channel on your transceiver?**

- A. Enable the frequency offset
- B. Store it in a memory channel
- C. Enable the VOX
- D. Use the scan mode to select the desired frequency

**T7B10**

**What might be a problem if you receive a report that your audio signal through the repeater is distorted or unintelligible?**

- A. Your transmitter is slightly off frequency
- B. Your batteries are running low
- C. You are in a bad location
- D. All of these choices are correct

## **HT Inside Car**

### **Inside a metal box**

- Does not work well
- 

**T9A07**

**What is a disadvantage of using a handheld VHF transceiver with a flexible antenna inside a vehicle?**

- A. Signal strength is reduced due to the shielding effect of the vehicle
- B. The bandwidth of the antenna will decrease, increasing SWR
- C. The SWR might decrease, decreasing the signal strength
- D. All these choices are correct

# UHF – VHF Long-Distance

## SSB

- Requires Multi-mode radio
- Upper sideband

## Horizontal antenna

---

### T8A03

Which type of voice mode is most often used for long-distance (weak signal) contacts on the VHF and UHF bands?

- A. FM
- B. DRM
- C. SSB
- D. PM

### T8A06

Which sideband is normally used for 10 meter HF, VHF, and UHF single-sideband communications?

- A. Upper sideband
- B. Lower sideband
- C. Suppressed sideband
- D. Inverted sideband

# REPEATER

## Retransmits

Typically from a high location  
Provides greater range for HTs  
Automatic Control no operator  
Requires two frequencies  
Input / Output

## Used responsible for transmission

### Lots of repeaters in metro areas

Coordination “required”  
Local group of repeater owners

### Paid for by owner

Individuals  
Clubs      Open repeaters GOOD!  
Groups     Closed repeaters BOO!

## Linked

Echolink VoIP – Internet  
Audio repeated on all net members

**T1A08 [97.3(a)(22)]**

**Which of the following entities recommends transmit/receive channels and other parameters for auxiliary and repeater stations?**

- A. Frequency Spectrum Manager appointed by the FCC
- B. Volunteer Frequency Coordinator recognized by local amateurs
- C. FCC Regional Field Office
- D. International Telecommunications Union

**T1A09 [97.3(a)(22)]**

**Who selects a Frequency Coordinator?**

- A. The FCC Office of Spectrum Management and Coordination Policy
- B. The local chapter of the Office of National Council of Independent Frequency Coordinators
- C. Amateur operators in a local or regional area whose stations are eligible to be repeater or auxiliary stations
- D. FCC Regional Field Office

**T1E08 [97.3(a)(6), 97.205(d)]**

**Which of the following is an example of automatic control?**

- A. Repeater operation
- B. Controlling the station over the internet
- C. Using a computer or other device to send CW automatically
- D. Using a computer or other device to identify automatically

**T1F10 [97.205(g)]**

**Who is accountable if a repeater inadvertently retransmits communications that violate the FCC Rules?**

- A. The control operator of the originating station
- B. The control operator of the repeater
- C. The owner of the repeater
- D. Both the originating station and the repeater owner

**T1F09 [97.3(a)(40)]**

**What type of amateur station simultaneously retransmits the signal of another amateur station on a different channel or channels?**

- A. Beacon station
- B. Earth station
- C. Repeater station
- D. Message forwarding station

**T2B03**

**Which of the following describes a linked repeater network?**

- A. A network of repeaters in which signals received by one repeater are transmitted by all the repeaters in the network
- B. A single repeater with more than one receiver
- C. Multiple repeaters with the same control operator
- D. A system of repeaters linked by APRS

# REPEATER TECH STUFF

## • Repeaters

- Use FM for reduction of noise
- Split frequencies
  - Transmit on one frequency
  - Receive on another frequency
  - 600 kHz on 2 Meters
  - 1.6 MHz on 1.25 Meters
  - 5.0 MHz on 70 Centimeters
- Interference reduction
  - PL tone
    - Also called CTCSS
    - A low frequency used to reduce repeater interference
    - 50 to 250 Hz
  - Tone burst or DCS
- Multiple receivers
  - “Auxiliary stations”

## T2A01

**What is a common repeater frequency offset in the 2 meter band?**

- A. Plus or minus 5 MHz
- B. Plus or minus 600 kHz
- C. Plus or minus 500 kHz
- D. Plus or minus 1 MHz

## T2A03

**What is a common repeater frequency offset in the 70 cm band?**

- A. Plus or minus 5 MHz
- B. Plus or minus 600 kHz
- C. Plus or minus 500 kHz
- D. Plus or minus 1 MHz

## T2A07

**What is meant by "repeater offset"?**

- A. The difference between a repeater's transmit frequency and its receive frequency
- B. The repeater has a time delay to prevent interference
- C. The repeater station identification is done on a separate frequency
- D. The number of simultaneous transmit frequencies used by a repeater

**T2B02**

**What term describes the use of a sub-audible tone transmitted along with normal voice audio to open the squelch of a receiver?**

- A. Carrier squelch
- B. Tone burst
- C. DTMF
- D. CTCSS

**T2B04**

**Which of the following could be the reason you are unable to access a repeater whose output you can hear?**

- A. Improper transceiver offset
- B. You are using the wrong CTCSS tone
- C. You are using the wrong DCS code
- D. All these choices are correct

**T8A04**

**Which type of modulation is most commonly used for VHF and UHF voice repeaters?**

- A. AM
- B. SSB
- C. PSK
- D. FM or PM

**T2B06**

**What type of signaling uses pairs of audio tones?**

- A. DTMF
- B. CTCSS
- C. GPRS
- D. D-STAR

- **Autopatch**

- Connection to telephone network
- One BIG party line!

- **Courtesy tone**

- Wait for the tone
- Time to break in – Say you call

- **User responsible for input**

- **Calling CQ**

- CQ not used on repeaters
- Just say your call

- **Calling another station**

- Say stations call then Your call

- **Time-out timer**

- Turns off repeater if you talk too long

- **ID**

- Morse 20 WPM max
- Voice

- **Modes other than voice NOT welcome**

- Check with owner

**T2A04**

**What is an appropriate way to call another station on a repeater if you know the other station's call sign?**

- A. Say "break, break," then say the station's call sign
- B. Say the station's call sign, then identify with your call sign
- C. Say "CQ" three times, then the other station's call sign
- D. Wait for the station to call CQ, then answer it

**T2A09**

**Which of the following indicates that a station is listening on a repeater and looking for a contact?**

- A. "CQ CQ" followed by the repeater's call sign
- B. The station's call sign followed by the word "monitoring"
- C. The repeater call sign followed by the station's call sign
- D. "QSX" followed by your call sign

## Internet linked repeater

- **Echolink & IRLP**

- Check repeater directory
- Must Register to use Echolink
- Voice Over Internet Protocol (VoIP)
  - Check on line
  - Check repeater directory

- **IRLP**

- Uses DTMF (TT) to connect
- Gateway
  - Connection from radio to internet

**T8C06**

**How is over the air access to IRLP nodes accomplished?**

- A. By obtaining a password that is sent via voice to the node
- B. By using DTMF signals
- C. By entering the proper internet password
- D. By using CTCSS tone codes

**T8C07**

**What is Voice Over Internet Protocol (VoIP)?**

- A. A set of rules specifying how to identify your station when linked over the internet to another station
- B. A technique employed to “spot” DX stations via the internet
- C. A technique for measuring the modulation quality of a transmitter using remote sites monitored via the internet
- D. A method of delivering voice communications over the internet using digital techniques

**T8C08**

**What is the Internet Radio Linking Project (IRLP)?**

- A. A technique to connect amateur radio systems, such as repeaters, via the internet using Voice Over Internet Protocol (VoIP)
- B. A system for providing access to websites via amateur radio
- C. A system for informing amateurs in real time of the frequency of active DX stations
- D. A technique for measuring signal strength of an amateur transmitter via the internet

**T8C10**

**What is required before using the EchoLink system?**

- A. Complete the required EchoLink training
- B. Purchase a license to use the EchoLink software
- C. Register your call sign and provide proof of license
- D. All these choices are correct

**T8C11**

**What is an amateur radio station that connects other amateur stations to the internet?**

- A. A gateway
- B. A repeater
- C. A digipeater
- D. A beacon

**T8C09**

**Which of the following protocols enables an amateur station to transmit through a repeater without using a radio to initiate the transmission?**

- A. IRLP
- B. D-STAR
- C. DMR
- D. EchoLink



## **LINKED REPEATERS**

### **Repeaters linked by**

- Radio
- Internet
- Wire

**What one repeater receives is transmitted on all repeaters**

## **DIGITAL MOBILE RADIO**

**Vocoders used to send digital voice**

**Can send digital data (texting)**

**Can form Talk Groups**

- Need to program ID number
- Channel Sharing

**Has Forward Error Correction**

**Color codes required CC0-15**

- Like PL

**Has compatibility problems**

**Can be internet linked - Hot spot**

**Time-multiplexing of two digital voice signals on a single 12.5 kHz repeater channel**

**Code plug**

- Repeater – Talk group - Info<sub>242</sub>

**T8D02****What is a “talkgroup” on a DMR repeater?**

- A. A group of operators sharing common interests
- B. A way for groups of users to share a channel at different times without being heard by other users on the channel
- C. A protocol that increases the signal-to-noise ratio when multiple repeaters are linked together
- D. A net that meets at a particular time

**T8D07****Which of the following describes DMR?**

- A. A technique for time-multiplexing two digital voice signals on a single 12.5 kHz repeater channel
- B. An automatic position tracking mode for FM mobiles communicating through repeaters
- C. An automatic computer logging technique for hands-off logging when communicating while operating a vehicle
- D. A digital technique for transmitting on two repeater inputs simultaneously for automatic error correction

**T2B07****How can you join a digital repeater’s “talk group”?**

- A. Register your radio with the local FCC office
- B. Join the repeater owner’s club
- C. Program your radio with the group’s ID or code
- D. Sign your call after the courtesy tone

**T2B12****What is the purpose of the color code used on DMR repeater systems?**

- A. Must match the repeater color code for access
- B. Defines the frequency pair to use
- C. Identifies the codec used
- D. Defines the minimum signal level required for access

**T4B07****What does a DMR “code plug” contain?**

- A. Your call sign in CW for automatic identification
- B. Access information for repeaters and talkgroups
- C. The codec for digitizing audio
- D. The DMR software version

**T4B09****How is a specific group of stations selected on a digital voice transceiver?**

- A. By retrieving the frequencies from transceiver memory
- B. By enabling the group’s CTCSS tone
- C. By entering the group’s identification code
- D. By activating automatic identification

**T4A10**

**What function is performed with a transceiver and a digital mode hot spot?**

- A. Communication using digital voice or data systems via the internet
- B. FT8 digital communications via AFSK
- C. RTTY encoding and decoding without a computer
- D. High-speed digital communications for meteor scatter

# D\_STAR

**Must register your call with D-Star  
Program your call into your radio**

---

**T4B11**

**Which of the following must be programmed into a D-STAR digital transceiver before transmitting?**

- A. Your call sign
- B. Your output power
- C. The codec type being used
- D. All these choices are correct

## CROSS-BAND REPEATER

- **Receive on one band**
- **Transmit on a different band**
  - Satellites
    - Automatic stations
  - Mobile and HTs
    - Require an operator “Ha Ha”

## SIMPLEX OPERATION

- **Transmit & receive on the same frequency**
- **Use assigned frequencies not repeater frequencies**
- **National calling frequencies**
  - 146.52
  - 446.00
- **Use instead of repeater when you can (check input frequency - reverse split)**
- **Some HAMs use the output frequency of the local repeater for simplex**

---

### T2A02

**What is the national calling frequency for FM simplex operations in the 2 meter band?**

- A. 146.520 MHz
- B. 145.000 MHz
- C. 432.100 MHz
- D. 446.000 MHz

**T2A11**

**What term describes an amateur station that is transmitting and receiving on the same frequency?**

- A. Full duplex
- B. Diplex
- C. Simplex
- D. Multiplex

**T2B01**

**How is a VHF/UHF transceiver's "reverse" function used?**

- A. Reduce power output
- B. Increase power output
- C. Listen on a repeater's input frequency
- D. Listen on a repeater's output frequency

**T2B09**

**Why are simplex channels designated in the VHF/UHF band plans?**

- A. So stations within range of each other can communicate without tying up a repeater
- B. For contest operation
- C. For working DX only
- D. So stations with simple transmitters can access the repeater without automated offset

## Operation 2

- **Frequency use**

- Nets

- Gentlemen
  - Ask to move

- Breaking in

- Your call

- Busy frequency

- Move

- **Amateur Auxiliary**

- Cops

- Stay away from band edges

- Can put you outside the band

# Space Stations

**Space = 50 km above the Earth**  
**International Space Station**  
**Satellites**

---

**T1A07 [97.3(a)(41)]**

**What is the FCC Part 97 definition of a space station?**

- A. Any satellite orbiting the earth
- B. A manned satellite orbiting the earth
- C. An amateur station located more than 50 km above the Earth's surface
- D. An amateur station using amateur radio satellites for relay of signals

**T1B02 [97.301, 97.207(c)]**

**Which amateurs may contact the International Space Station (ISS) on VHF bands?**

- A. Any amateur holding a General class or higher license
- B. Any amateur holding a Technician class or higher license
- C. Any amateur holding a General class or higher license who has applied for and received approval from NASA
- D. Any amateur holding a Technician class or higher license who has applied for and received approval from NASA

# SATELLITES

- **Most satellites are VHF or UHF**
  - Pass through the ionosphere easily
  - U/V mode UHF up VHF down
- **Use circular polarized antennas**
  - Satellites spin
- **LEO - Low Earth Orbit**
- **Tracking Programs**
  - Maps showing position
  - Time, Azimuth, and Elevation
  - Frequency
  - Doppler shift
  - Input Keplerian elements
    - 8 Values (internet search)

**T8B08**

**What is meant by the statement that a satellite is operating in mode U/V?**

- A. The satellite uplink is in the 15 meter band and the downlink is in the 10 meter band
- B. The satellite uplink is in the 70 centimeter band and the downlink is in the 2 meter band
- C. The satellite operates using ultraviolet frequencies
- D. The satellite frequencies are usually variable

**T8B10**

**What is a LEO satellite?**

- A. A sun synchronous satellite
- B. A highly elliptical orbit satellite
- C. A satellite in low energy operation mode
- D. A satellite in low earth orbit

**T8B09**

**What causes spin fading of satellite signals?**

- A. Circular polarized noise interference radiated from the sun
- B. Rotation of the satellite and its antennas
- C. Doppler shift of the received signal
- D. Interfering signals within the satellite uplink band

**T8B07**

**What is Doppler shift in reference to satellite communications?**

- A. A change in the satellite orbit
- B. A mode where the satellite receives signals on one band and transmits on another
- C. An observed change in signal frequency caused by relative motion between the satellite and the earth station
- D. A special digital communications mode for some satellites

**T1D07 [97.113(d)]**

**What types of amateur stations can automatically retransmit the signals of other amateur stations?**

- A. Auxiliary, beacon, or Earth stations
- B. Repeater, auxiliary, or space stations
- C. Beacon, repeater, or space stations
- D. Earth, repeater, or space stations

**T8B03**

**Which of the following are provided by satellite tracking programs?**

- A. Maps showing the real-time position of the satellite track over the earth
- B. The time, azimuth, and elevation of the start, maximum altitude, and end of a pass
- C. The apparent frequency of the satellite transmission, including effects of Doppler shift
- D. All of these choices are correct

**T8B06**

**Which of the following are inputs to a satellite tracking program?**

- A. The satellite transmitted power
- B. The Keplerian elements
- C. The last observed time of zero Doppler shift
- D. All these choices are correct

**T1E02 [97.301, 97.207(c)]**

**Who may be the control operator of a station communicating through an amateur satellite or space station?**

- A. Only an Amateur Extra Class operator
- B. A General class or higher licensee who has a satellite operator certification
- C. Only an Amateur Extra Class operator who is also an AMSAT member
- D. Any amateur whose license privileges allow them to transmit on the satellite uplink frequency

**T8B05**

**What is a satellite beacon?**

- A. The primary transmit antenna on the satellite
- B. An indicator light that shows where to point your antenna
- C. A reflective surface on the satellite
- D. A transmission from a satellite that contains status information

**T8B01**

**What telemetry information is typically transmitted by satellite beacons?**

- A. The signal strength of received signals
- B. Time of day accurate to plus or minus 1/10 second
- C. Health and status of the satellite
- D. All of these choices are correct

**T8B11**

**Who may receive telemetry from a space station?**

- A. Anyone
- B. A licensed radio amateur with a transmitter equipped for interrogating the satellite
- C. A licensed radio amateur who has been certified by the protocol developer
- D. A licensed radio amateur who has registered for an access code from AMSAT



T8B04

**What mode of transmission is commonly used by amateur radio satellites?**

- A. SSB
- B. FM
- C. CW/data
- D. All of these choices are correct

T8B02

**What is the impact of using too much effective radiated power on a satellite uplink?**

- A. Possibility of commanding the satellite to an improper mode
- B. Blocking access by other users
- C. Overloading the satellite batteries
- D. Possibility of rebooting the satellite control computer

T8B12

**Which of the following is a way to determine whether your satellite uplink power is neither too low nor too high?**

- A. Check your signal strength report in the telemetry data
- B. Listen for distortion on your downlink signal
- C. Your signal strength on the downlink should be about the same as the beacon
- D. All of these choices are correct

## ATV OPERATION

- **ID with your call in the picture**
  - **Allowed above 420 MHz**
  - **TV requires about 6 MHz bandwidth**
  - **You can pick-up ATV with a cable ready TV on CH 58**
  - **NTSC - TV Standard**
- 

T8D04

**What type of transmission is indicated by the term "NTSC?"**

- A. A Normal Transmission mode in Static Circuit
- B. A special mode for earth satellite uplink
- C. An analog fast scan color TV signal
- D. A frame compression scheme for TV signals

# Direction Finding

- **Find the bad guy**
  - **Equipment**
    - Directional antenna
    - Other
- 

## T8C01

**Which of the following methods is used to locate sources of noise interference or jamming?**

- A. Echolocation
- B. Doppler radar
- C. Radio direction finding
- D. Phase locking

## T8C02

**Which of these items would be useful for a hidden transmitter hunt?**

- A. Calibrated SWR meter
- B. A directional antenna
- C. A calibrated noise bridge
- D. All of these choices are correct

# APRS

**Automatic Position Reporting System  
Automatic Packet Reporting System**

- **Uses packet on 144.39 MHz**
  - **Requires GPS**
  - **Provides your location**
  - **Used for public service events**
- 

## T8D05

**Which of the following is an application of APRS ?**

- A. Providing real-time tactical digital communications in conjunction with a map showing the locations of stations
- B. Showing automatically the number of packets transmitted via PACTOR during a specific time interval
- C. Providing voice over internet connection between repeaters
- D. Providing information on the number of stations signed into a repeater

## T8D03

**What kind of data can be transmitted by APRS?**

- A. GPS position data
- B. Text messages
- C. Weather data
- D. All these choices are correct

# Contesting

- **Contacting many stations in weekend**
  - **Send only the info required**
  - **Know your grid locator**
    - Special Map – letter number
- 

## **T8C03**

**What operating activity involves contacting as many stations as possible during a specified period?**

- A. Simulated emergency exercises
- B. Net operations
- C. Public service events
- D. Contesting

## **T8C04**

**Which of the following is good procedure when contacting another station in a radio contest?**

- A. Sign only the last two letters of your call if there are many other stations calling
- B. Contact the station twice to be sure that you are in his log
- C. Send only the minimum information needed for proper identification and the contest exchange
- D. All of these choices are correct

## **T8C05**

**What is a grid locator?**

- A. A letter-number designator assigned to a geographic location
- B. A letter-number designator assigned to an azimuth and elevation
- C. An instrument for neutralizing a final amplifier
- D. An instrument for radio direction finding

# SUN

- **Solar Flares**
- **Coronal Mass Ejections**
  - Charged Particals
  - Spews Solar Plasma
    - 20 to 40 Hour to Affect Earth
  - Can Cause
    - Geomagnetic Disturbances (Storm)
      - Degrades HF Above or Below 45 Degrees
      - Aurora increase – Reflects VHF
    - Sudden Ionospheric Disturbances (D layer)
      - Raises the LUF
- **Measurement**
  - Sun Spot Number
    - Count of Sun Spots (Higher Better)
  - A Index
    - Long Term Magnetic Stability
  - K Index
    - Short Term Magnetic Stability
  - Solar Flux Index
    - Signal Strength at 10.7 cm or 28 GHz

263

# More SUN

- **Sun's rotation on its axis**
  - 28 day cycle
  - Changes HF propagation

264

# IONIZATION

It's All the Sun's Fault

F Layer = Good guy  
D Layer = Bad guy

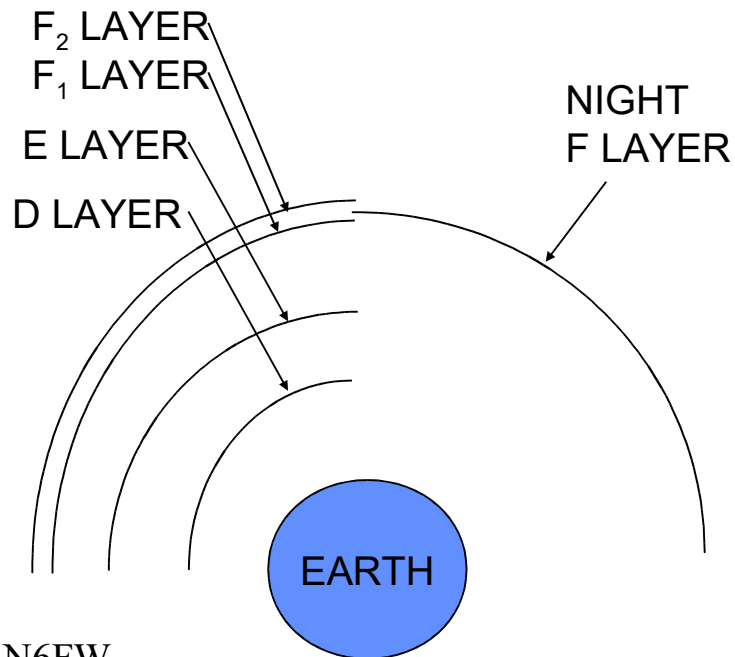

KN6FW

265

# IONOSPHERE

- **Caused by**
  - Solar radiation
  - Ultraviolet
    - 8 Min from Sun to Earth
  - Sunspots
    - Higher the Better
      - Raises the MUF (10-15 Meters work)
      - 20 Meters and up Work Always
    - 11 year cycle
    - Max 2013-2014
- **Bends radio waves**
- **Max at midday Summer**
- **Min just before dawn**
- **Changes polarization**
- **Can cause delay fading**

266

**T3A11**

**Which region of the atmosphere can refract or bend HF and VHF radio waves?**

- A. The stratosphere
- B. The troposphere
- C. The ionosphere
- D. The magnetosphere

**T3C02**

**What is a characteristic of HF communication compared with communications on VHF and higher frequencies?**

- A. HF antennas are generally smaller
- B. HF accommodates wider bandwidth signals
- C. Long distance ionospheric propagation is far more common on HF
- D. There is less atmospheric interference (static) on HF

**T3C09**

**What is generally the best time for long-distance 10 meter band propagation via the F layer?**

- A. From dawn to shortly after sunset during periods of high sunspot activity
- B. From shortly after sunset to dawn during periods of high sunspot activity
- C. From dawn to shortly after sunset during periods of low sunspot activity
- D. From shortly after sunset to dawn during periods of low sunspot activity

**T3C10**

**Which of the following bands may provide long-distance communications via the ionosphere's F region during the peak of the sunspot cycle?**

- A. 6 or 10 meter bands
- B. 23 centimeter band
- C. 70 centimeter or 1.25 meter bands
- D. All of these choices are correct

## Sudden Ionospheric Disturbance

- It disrupts signals on lower frequencies more than those on higher frequencies
- disturbance in the Earth's magnetosphere

269

## SKIP ZONE

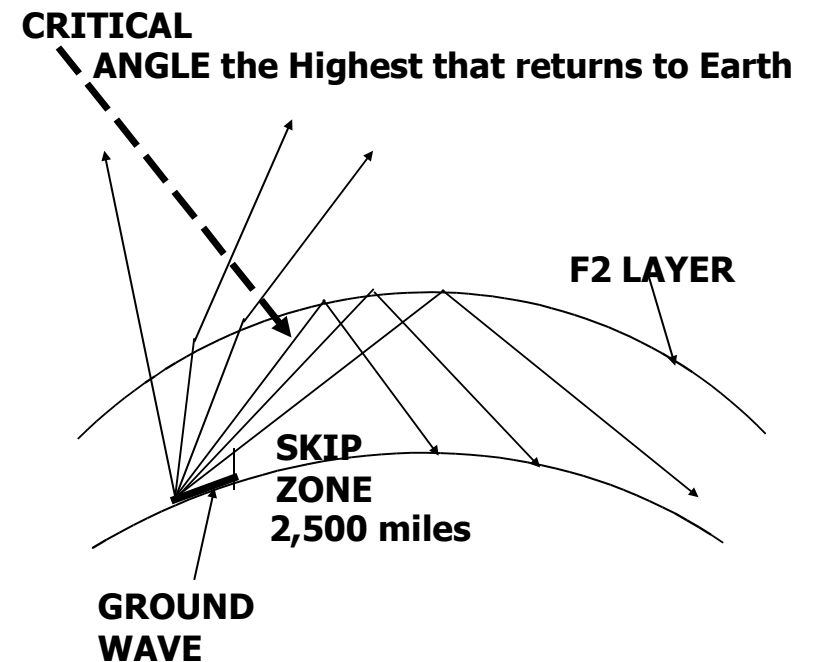

270

# PROPAGATION

- **Ground-wave**
  - Short range
- **Sky-wave**
  - Bounces off ionosphere
  - Changes polarization
  - Multi-paths (Cause Fading)
  - Multi-hop bounces multiple times
  - Long range
- **Skip zone**
  - No signal (Scatter Only)
  - Between ground wave and first bounce
- **Scatter**
  - E layer (1 Hop = 1,200 miles)

# Scatter

- **Not a nice reflector (Low Return)**
- **Weak signals (Power Scattered)**
- **Wavering sound (multi path)**
- **Gets into skip zone**
- **Gets thru above MUF**



**T3A08**

**What is a likely cause of irregular fading of signals propagated by the ionosphere?**

- A. Frequency shift due to Faraday rotation
- B. Interference from thunderstorms
- C. Intermodulation distortion
- D. Random combining of signals arriving via different paths

**T3A09**

**Which of the following results from the fact that skip signals refracted from the ionosphere are elliptically polarized?**

- A. Digital modes are unusable
- B. Either vertically or horizontally polarized antennas may be used for transmission or reception
- C. FM voice is unusable
- D. Both the transmitting and receiving antennas must be of the same polarization

## **MUF-LUF**

**Max usable frequency (MUF)**

**Highest frequency to return to earth**

**Best frequency just below MUF**

**Changes with ionization**

**Lowest usable frequency (LUF)**

**Absorbed by the D Layer**

## Beacon Stations

- **Propagation Signal**
- **100 Watt Max**
- **1 Transmitter per Location per Frequency**
- **Hearing the Signal Means You Can Communicate**
- **Listen for W W V Colorado or W W V H Hawaii on 2.5, 5, 10, 15, 20 MHZ**

---

**T1A06 [97.3(a)(9)]**

**What is the FCC Part 97 definition of a beacon?**

- A. A government transmitter marking the amateur radio band edges
- B. A bulletin sent by the FCC to announce a national emergency
- C. A continuous transmission of weather information authorized in the amateur bands by the National Weather Service
- D. An amateur station transmitting communications for the purposes of observing propagation or related experimental activities

275

## VHF-UHF PROPAGATION

- **Line of sight**
- **Absorption by vegetation, fog or rain**
- **Ducting**
  - Tropospheric bounce
  - Drops off with increasing frequency
  - Happens at up to 11 miles up
  - Temperature inversion
    - High-pressure system
  - 2 meters
- **Meteor scatter**
  - Best on 6 Meters
- **Sky-wave**
  - Happens in good times
  - 6 and 2 meters
  - E region
  - Sporadic E
  - Short hop on 10 meters as an indicator

276

### T3C08

**What causes tropospheric ducting?**

- A. Discharges of lightning during electrical storms
- B. Sunspots and solar flares
- C. Updrafts from hurricanes and tornadoes
- D. Temperature inversions in the atmosphere

### T3C04

**Which of the following propagation types is most commonly associated with occasional strong over-the-horizon signals on the 10, 6, and 2 meter bands?**

- A. Backscatter
- B. Sporadic E
- C. D layer absorption
- D. Gray-line propagation

### T3C06

**What mode is responsible for allowing over-the-horizon VHF and UHF communications to ranges of approximately 300 miles on a regular basis?**

- A. Tropospheric ducting
- B. D layer refraction
- C. F2 layer refraction
- D. Faraday rotation

### T3C07

**What band is best suited for communicating via meteor scatter?**

- A. 33 centimeters
- B. 6 meters
- C. 2 meters
- D. 70 centimeters

277

## VHF-UHF PROPAGATION

- Line of Sight
    - Radio Horizon
    - Goes thru the Ionosphere
  - Reflections
    - Phase changes
      - Fading
      - Picket Fencing
      - Data errors
    - Auroral
      - Rapid Strength Changes
      - Sounds distorted
- 

### T3C01

**Why are simplex UHF signals rarely heard beyond their radio horizon?**

- A. They are too weak to go very far
- B. FCC regulations prohibit them from going more than 50 miles
- C. UHF signals are usually not propagated by the ionosphere
- D. UHF signals are absorbed by the ionospheric D region

KN6FW

278

**T3C03**

**What is a characteristic of VHF signals received via auroral backscatter?**

- A. They are often received from 10,000 miles or more
- B. They are distorted and signal strength varies considerably
- C. They occur only during winter nighttime hours
- D. They are generally strongest when your antenna is aimed west

**T3C11**

**Why is the radio horizon for VHF and UHF signals more distant than the visual horizon?**

- A. Radio signals move somewhat faster than the speed of light
- B. Radio waves are not blocked by dust particles
- C. The atmosphere refracts radio waves slightly
- D. Radio waves are blocked by dust particles

## VHF-UHF PROPAGATION 2

- Same Polarization Required
  - Repeaters are Vertical
  - Fields Electric – Magnetic at 90 degrees
  - Electric = Polarization
- Short Wavelength
  - Penetrate Buildings
- Knife-edge
  - Refraction over sharp edges
  - Top of a hill

---

**T3B02**

What property of a radio wave is used to describe its polarization?

- A. The orientation of the electric field
- B. The orientation of the magnetic field
- C. The ratio of the energy in the magnetic field to the energy in the electric field
- D. The ratio of the velocity to the wavelength

**T3B03**

**What are the two components of a radio wave?**

- A. Impedance and reactance
- B. Voltage and current
- C. Electric and magnetic fields
- D. Ionizing and non-ionizing radiation

**T3B01**

**What is the relationship between the electric and magnetic fields of an electromagnetic wave?**

- A. They travel at different speeds
- B. They are in parallel
- C. They revolve in opposite directions
- D. They are at right angles

**T3A05**

**When using a directional antenna, how might your station be able to access a distant repeater if buildings or obstructions are blocking the direct line of sight path?**

- A. Change from vertical to horizontal polarization
- B. Try to find a path that reflects signals to the repeater
- C. Try the long path
- D. Increase the antenna SWR

**T3A06**

**What is the meaning of the term “picket fencing”?**

- A. Alternating transmissions during a net operation
- B. Rapid flutter on mobile signals due to multipath propagation
- C. A type of ground system used with vertical antennas
- D. Local vs long-distance communications

**T3A12**

**How might fog and light rain affect radio range on the 10 meter and 6 meter bands?**

- A. Absorption
- B. There is little effect
- C. Deflection
- D. Range increase

**T3A07**

**What weather condition would decrease range at microwave frequencies?**

- A. High winds
- B. Low barometric pressure
- C. Precipitation
- D. Colder temperatures

**T3C05**

**Which of the following effects may allow radio signals to travel beyond obstructions between the transmitting and receiving stations?**

- A. Knife-edge diffraction
- B. Faraday rotation
- C. Quantum tunneling
- D. Doppler shift

**T3A01**

**Why do VHF signal strengths sometimes vary greatly when the antenna is moved only a few feet?**

- A. The signal path encounters different concentrations of water vapor
- B. VHF ionospheric propagation is very sensitive to path length
- C. Multipath propagation cancels or reinforces signals
- D. All these choices are correct

**T3A02**

**What is the effect of vegetation on UHF and microwave signals?**

- A. Knife-edge diffraction
- B. Absorption
- C. Amplification
- D. Polarization rotation

## **VHF WEAK-SIGNAL**

- **CW**
  - Lowest bandwidth
- **SSB**
  - ½ an AM Signal
  - Low bandwidth
  - Upper sideband
- **Multi-mode radio required**
- **Antenna**
  - Horizontal polarized
  - Big
- **Tropospheric scatter**
  - About 300 Miles
- **Meteor scatter**
  - 6 Meters

**T3A03**

**What antenna polarization is normally used for long-distance CW and SSB contacts on the VHF and UHF bands?**

- A. Right-hand circular
- B. Left-hand circular
- C. Horizontal
- D. Vertical

# RF Interference 1

## Fundamental overload

- Bad Receiver Design

## Harmonics

- Transmitter Tuning

## Spurious emissions

- Transmitter tuning
- Covers not in place

---

**T7B03**

**Which of the following can cause radio frequency interference?**

- A. Fundamental overload
- B. Harmonics
- C. Spurious emissions
- D. All of these choices are correct

## RF Interference 2

- **Audio devices**
  - Diodes make receivers
    - Oxidation counts too
  - Bypass Caps Short-Out RF
  - Ferrite Beads to Absorb RF
  - Shielded Wire
  - SSB - Sounds distorted
  - CW - Clicks or Clicks & Hum
- **Radio**
  - Broadband noise
    - Spark gap TX
    - Arcing
  - Diodes make mixers too
    - Oxidation counts too

287

### T6D03

**Which of the following is a reason to use shielded wire?**

- A. To decrease the resistance of DC power connections
- B. To increase the current carrying capability of the wire
- C. To prevent coupling of unwanted signals to or from the wire
- D. To couple the wire to other signals

288



## RF Feedback

**Some RF signal gets back into your radio's mic connection**

- Garbled
- Distorted,
- Unintelligible voice

---

### T7B11

**What is a symptom of RF feedback in a transmitter or transceiver?**

- A. Excessive SWR at the antenna connection
- B. The transmitter will not stay on the desired frequency
- C. Reports of garbled, distorted, or unintelligible voice transmissions
- D. Frequent blowing of power supply fuses

289

## TVI

- Television interference
- Check your TV first
- Harmonics
  - Channels depend on operating frequency
- Filters
  - High pass
    - On TV
    - Cuts HF frequencies
  - Low pass
    - On transmitter
    - Reduces harmonics
  - Band reject
    - Passes all but a small band
    - Keep 2 meters out of a TV
- Cable TV – Check all cableTV connectors
  - Can interfere with ham radio

290

**T7B06**

**Which of the following actions should you take if a neighbor tells you that your station's transmissions are interfering with their radio or TV reception?**

- A. Make sure that your station is functioning properly and that it does not cause interference to your own radio or television when it is tuned to the same channel
- B. Immediately turn off your transmitter and contact the nearest FCC office for assistance
- C. Install a harmonic doubler on the output of your transmitter and tune it until the interference is eliminated
- D. All these choices are correct

**T7B09**

**What should be the first step to resolve non-fiber optic cable TV interference caused by your amateur radio transmission?**

- A. Add a low-pass filter to the TV antenna input
- B. Add a high-pass filter to the TV antenna input
- C. Add a preamplifier to the TV antenna input
- D. Be sure all TV feed line coaxial connectors are installed properly

# FILTERS

- **Low pass**
  - Passes frequencies below filter cut-off
    - Use on your transmitter
    - Reduces harmonic radiation
- **High pass**
  - Passes frequencies above filter cut-off
    - Use between antenna and TV set
    - **Not** needed on cable
- **Notch**
  - Removes a small piece of spectrum
- **Band pass**
  - Pass a small piece of spectrum
    - Used in receivers to tune the station you want
    - Rejects all frequencies except a small band

**T7B05**

**How can fundamental overload of a non-amateur radio or TV receiver by an amateur signal be reduced or eliminated?**

- A. Block the amateur signal with a filter at the antenna input of the affected receiver
- B. Block the interfering signal with a filter on the amateur transmitter
- C. Switch the transmitter from FM to SSB
- D. Switch the transmitter to a narrow-band mode

**T7B07**

**Which of the following can reduce overload to a VHF transceiver from a nearby FM broadcast station?**

- A. Installing an RF preamplifier
- B. Using double-shielded coaxial cable
- C. Installing bypass capacitors on the microphone cable
- D. Installing a band-reject filter

## **Interference Not Your Fault**

- **Telephone**
  - Poorly designed phones may receive radio signals
  - Line filters may help
    - Do not install it for anyone
- **Receiver Overload**
  - Poorly designed radios-TVs
  - Fundamental overload
- **Part 15 devices**
  - May cause interference

**T7B02**

**What would cause a broadcast AM or FM radio to receive an amateur radio transmission unintentionally?**

- A. The receiver is unable to reject strong signals outside the AM or FM band
- B. The microphone gain of the transmitter is turned up too high
- C. The audio amplifier of the transmitter is overloaded
- D. The deviation of an FM transmitter is set too low

**T7B04**

**Which of the following could you use to cure distorted audio caused by RF current on the shield of a microphone cable?**

- A. Band-pass filter
- B. Low-pass filter
- C. Preamplifier
- D. Ferrite choke

**T7B08**

**What should you do if something in a neighbor's home is causing harmful interference to your amateur station?**

- A. Work with your neighbor to identify the offending device
- B. Politely inform your neighbor about the rules that prohibit the use of devices that cause interference
- C. Check your station and make sure it meets the standards of good amateur practice
- D. All of these choices are correct

## Audio Cable - RF

- **RF can induce Current into Audio Cables**
- **Place Clamp-on ferrite choke on Cable**

## RF SAFETY

- **You are responsible**
- **RF CAN BURN**
  - It feels like a burn not a shock
  - Keep antennas away from people
  - Antenna high and out of reach
- **RF CAN HEAT**
  - Microwave oven!
  - Heating is frequency dependent
  - You do **not** need to touch the antenna or feedline to heat the body
  - Very dangerous to eyes
    - *Cataracts*

### T0C07

**What hazard is created by touching an antenna during a transmission?**

- A. Electrocutation
- B. RF burn to skin
- C. Radiation poisoning
- D. All these choices are correct

### T0C13

**Who is responsible for ensuring that no person is exposed to RF energy above the FCC exposure limits?**

- A. The FCC
- B. The station licensee
- C. Anyone who is near an antenna
- D. The local zoning board

## LIMITS SET?

- **MAXIMUM PERMITTED EXPOSURE (MPE)**

- How much heat should the body be exposed to?
  - Whole-body specific absorption rate (sar)
- Controlled by
  - Frequency
  - Distance from antenna
  - Power of the transmitter
  - Gain of the antenna
  - Time the transmitter is on
  - Type of modulation

## T0C11

**What is the definition of duty cycle during the averaging time for RF exposure?**

- A. The difference between the lowest power output and the highest power output of a transmitter
- B. The difference between the PEP and average power output of a transmitter
- C. The percentage of time that a transmitter is transmitting
- D. The percentage of time that a transmitter is not transmitting

# DEFINITIONS

- **CONTROLLED SPACE**
  - You and your family
  - 6 minute averaging
- **UNCONTROLLED SPACE**
  - Your neighbors
  - No control of exposure
  - 30 minute averaging
- **NONIONIZING RADIATION**
  - Electromagnetic
  - Radio
  - Below ultraviolet
  - Heats the body

## T0C01

**What type of radiation are radio signals?**

- A. Gamma radiation
- B. Ionizing radiation
- C. Alpha radiation
- D. Non-ionizing radiation

## T0C12

**How does RF radiation differ from ionizing radiation (radioactivity)?**

- A. RF radiation does not have sufficient energy to cause genetic damage
- B. RF radiation can only be detected with an RF dosimeter
- C. RF radiation is limited in range to a few feet
- D. RF radiation is perfectly safe

# MEASUREMENT UNITS

- **ELECTRIC FIELD**
  - VOLTS per METER (V/m)
- **MAGNETIC FIELD**
  - AMPERES per METER (A/m)
- **POWER DENSITY**
  - MILLIWATTS<sup>2</sup> per CENTIMETER<sup>2</sup> (mW/cm<sup>2</sup>)
- **MAKING MEASUREMENTS?**
  - You can't!
  - Instruments are expensive
  - Reading affected by
    - The probe
    - People
    - Ground interaction
    - Other wires ---

303

## T0C06

**Which of the following is an acceptable method to determine that your station complies with FCC RF exposure regulations?**

- A. By calculation based on FCC OET Bulletin 65
- B. By calculation based on computer modeling
- C. By measurement of field strength using calibrated equipment
- D. All of these choices are correct

## T0C09

**How can you make sure your station stays in compliance with RF safety regulations?**

- A. By informing the FCC of any changes made in your station
- B. By re-evaluating the station whenever an item of equipment is changed
- C. By making sure your antennas have low SWR
- D. All of these choices are correct

304



# POWER vs. DISTANCE

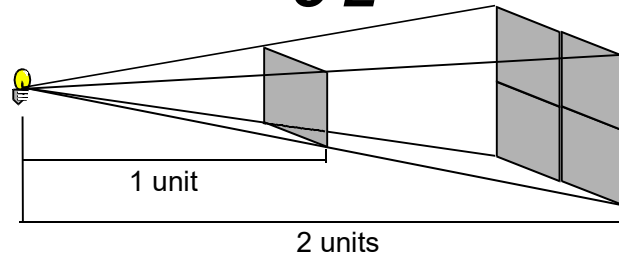

## EXPOSURE POWER

- Inversely proportional to the distance squared
- Directly proportional to:
  - Transmitter power
  - Transmitter duty cycle
  - Antenna gain
  - Modulation Type
    - FM = Always on
    - CW = Only when keyed
    - SSB = Lowest

305

### T0C04

**What factors affect the RF exposure of people near an amateur station antenna?**

- A. Frequency and power level of the RF field
- B. Distance from the antenna to a person
- C. Radiation pattern of the antenna
- D. All of these choices are correct

### T0C10

**Why is duty cycle one of the factors used to determine safe RF radiation exposure levels?**

- A. It affects the average exposure to radiation
- B. It affects the peak exposure to radiation
- C. It takes into account the antenna feed line loss
- D. It takes into account the thermal effects of the final amplifier

306

## MPE the FCC & YOU

- **FCC specifies exposure limits**
  - Specified in Part 97 & Part 1
  - You can
    - Measure the exposure
    - Calculate with computer programs
    - Calculate based on FCC Part 1 & Office of Engineering and Technology Bulletin No. 65
  - Re-evaluate for any change of equipment
  - You have to indicate your understanding of the exposure limits on your 610 form
  - No records are required **-BUT**

307

## What If? You Exceed MPE

- **Move Antenna**
  - **Reduce Power**
  - **Reduce Time On the Air**
  - **All To Reduce Human Exposure**
- 

### T0C08

**Which of the following actions can reduce exposure to RF radiation?**

- A. Relocate antennas
- B. Relocate the transmitter
- C. Increase the duty cycle
- D. All of these choices are correct

### T0C10

**Why is duty cycle one of the factors used to determine safe RF radiation exposure levels?**

- A. It affects the average exposure of people to radiation
- B. It affects the peak exposure of people to radiation
- C. It takes into account the antenna feed line loss
- D. It takes into account the thermal effects of the final amplifier

308

## **COMMON SENSE and RF EXPOSURE**

- **Keep antennas high & out of reach**
- **Keep people away from antennas**
- **Keep hand-held radio antennas away from your head & others**
- **Mount your mobile antenna on the roof of the car (rubber duck antennas don't work well in cars)**
- **Keep all shields in place**
- **Use coax not open line**
- **Use minimum power**
- **Turn off the transmitter before working on your antenna**
- **Keep exposure levels below limits**

309

## **WHY, WHAT and EXCEPTIONS**

- **Why**
  - So you won't cook your neighbors or your family
- **What**
  - Radio frequency 3 kHz to 300 GHz
  - Limits on 300 kHz to 100 GHz
  - Limits hardest 30 MHz to 300 MHz
    - body most sensitive
- **Exception**
  - Transmitters below 50 Watts (PEP)
  - 40 Meters and below 500 Watts

310

**T0C02**

**Which of the following frequencies has the lowest value for Maximum Permissible Exposure limit?**

- A. 3.5 MHz
- B. 50 MHz
- C. 440 MHz
- D. 1296 MHz

**T0C03**

**How does the allowable power density for RF safety change if duty cycle changes from 100 percent to 50 percent?**

- A. It increases by a factor of 3
- B. It decreases by 50 percent
- C. It increases by a factor of 2
- D. There is no adjustment allowed for lower duty cycle

**T0C05**

**Why do exposure limits vary with frequency?**

- A. Lower frequency RF fields have more energy than higher frequency fields
- B. Lower frequency RF fields do not penetrate the human body
- C. Higher frequency RF fields are transient in nature
- D. The human body absorbs more RF energy at some frequencies than at others

# Tower 1

## Installation

Stay away from Power wires

10 Ft Space in any Direction

Max height **200 ft**

Check height limit near Airport

Use Gin Pole to add sections

Guy wires per manufacturers instructions

Use Stainless steel hardware

Ground each leg to a Ground rod. Bond everything, do not solder

Safety wire turnbuckles

## Tower 2

### Climbing

- Turn off everything on the tower
- Point D ring hooks away from tower
- Safety belt
- Hard Hat
- Safety Glasses
- Helper Required
- Check for Damage
- Check Guy wires
- Check Turnbuckle safety wire
- Not in a Lightning storm
- Crank-up tower when down or locked

313

## MECHANICAL SAFETY

### Safety equipment

- Safety belt
- Hard hat
- Safety glasses

### Power lines

### Tower Climbing

#### Get someone to help you

*Make sure they have a hard hat and safety glasses*

#### Be sure the tower is in good shape

#### Get everything you need before climbing

#### Check tower guy wires

- Frayed wires
- Loose cables
- Loose turnbuckles
- Loose anchors
- Rusty cable

Climb **crank-up** towers only when Down

314

**T0B04**

**Which of the following is an important safety precaution to observe when putting up an antenna tower?**

- A. Wear a ground strap connected to your wrist at all times
- B. Insulate the base of the tower to avoid lightning strikes
- C. Look for and stay clear of any overhead electrical wires
- D. All of these choices are correct

**T0B06**

**What is the minimum safe distance from a power line to allow when installing an antenna?**

- A. Half the width of your property
- B. The height of the power line above ground
- C. 1/2 wavelength at the operating frequency
- D. Enough so that if the antenna falls unexpectedly, no part of it can come closer than 10 feet to the power wires

**T0B05**

**What is the purpose of a safety wire through a turnbuckle used to tension guy lines?**

- A. Secure the guy line if the turnbuckle breaks
- B. Prevent loosening of the turnbuckle from vibration
- C. Provide a ground path for lightning strikes
- D. Provide an ability to measure for proper tensioning

**T0B02**

**What is required when climbing an antenna tower?**

- A. Have sufficient training on safe tower climbing techniques
- B. Use appropriate tie-off to the tower at all times
- C. Always wear an approved climbing harness
- D. All these choices are correct

**T0B03**

**Under what circumstances is it safe to climb a tower without a helper or observer?**

- A. When no electrical work is being performed
- B. When no mechanical work is being performed
- C. When the work being done is not more than 20 feet above the ground
- D. Never

**T0B09**

**Why should you avoid attaching an antenna to a utility pole?**

- A. The antenna will not work properly because of induced voltages
- B. The 60 Hz radiations from the feed line may increase the SWR
- C. The antenna could contact high-voltage power lines
- D. All these choices are correct

**T0B08**

**What is considered to be a proper grounding method for a tower?**

- A. A single four-foot ground rod, driven into the ground no more than 12 inches from the base
- B. A ferrite-core RF choke connected between the tower and ground
- C. A connection between the tower base and a cold water pipe
- D. Separate eight-foot ground rods for each tower leg, bonded to the tower and each other

**T0B01**

**Which of the following is good practice when installing ground wires on a tower for lightning protection?**

- A. Put a loop in the ground connection to prevent water damage to the ground system
- B. Make sure that all bends in the ground wires are clean, right-angle bends
- C. Ensure that connections are short and direct
- D. All of these choices are correct

**T0B07**

**Which of the following is an important safety rule to remember when using a crank-up tower?**

- A. This type of tower must never be painted
- B. This type of tower must never be grounded
- C. This type of tower must not be climbed unless retracted mechanical safety locking devices have been installed
- D. All of these choices are correct

317

# STATION SAFETY

**Ground all equipment**

Water pipe (NOT plastic)

8' copper clad ground rod

**AC power**

National electrical code

12 gage good for 20 Amps

14 gage good for 15 Amps

Fuse the hot side

Do not over fuse

Ground-fault

Color code

Black = hot

White = neutral

Green or copper = safety ground

AC plug

Brass screw = hot

Silver screw = neutral

Green screw = safety ground

318

**T0A03**

**In the United States, what circuit does black wire insulation indicate in a three-wire 120 V cable?**

- A. Neutral
- B. Hot
- C. Equipment ground
- D. The white wire

**T0A06**

**What is a good way to guard against electrical shock at your station?**

- A. Use three-wire cords and plugs for all AC powered equipment
- B. Connect all AC powered station equipment to a common safety ground
- C. Install mechanical interlocks in high-voltage circuits
- D. All of these choices are correct

# Lightning

**Disconnect & Ground Antennas**

**Unplug Equipment**

**Bond all grounds**

**Use Coax Lighting Protectors**

- Mount on Metal Plate
- Connect Plate to Ground

**Short and direct grounds**

**No sharp turns (very high frequency)**

**Ground per local electrical codes**



**T0B11**

**Which of the following establishes grounding requirements for an amateur radio tower or antenna?**

- A. FCC Part 97 Rules
- B. Local electrical codes
- C. FAA tower lighting regulations
- D. UL recommended practices

**T0A07**

**Where should a lightning arrester be installed in a coaxial feed line?**

- A. At the output connector of a transceiver
- B. At the antenna feed point
- C. At the ac power service panel
- D. On a grounded panel near where feed lines enter the building

**T0A09**

**What should be done to all external ground rods or earth connections?**

- A. Waterproof them with silicone caulk or electrical tape
- B. Keep them as far apart as possible
- C. Bond them together with heavy wire or conductive strap
- D. Tune them for resonance on the lowest frequency of operation

# Ground

**Rod in the Ground**

**Should be one point**

Ground loop

**National Electrical Code**

Electrical safety

**RF**

SHORT run of flat strap

No sharp turns

Avoid resonant length

---

**T0B10**

**Which of the following is true when installing grounding conductors used for lightning protection?**

- A. Only non-insulated wire must be used
- B. Wires must be carefully routed with precise right-angle bends
- C. Sharp bends must be avoided
- D. Common grounds must be avoided

**T4A08**

**Which of the following conductors is preferred for bonding at RF?**

- A. Copper braid removed from coaxial cable
- B. Steel wire
- C. Twisted-pair cable
- D. Flat copper strap

323

## **AC Power**

**Use ground fault interrupters**

Check the current going out &  
the current coming back

They should be the same

If not the GFI turns off

**Gas Generator**

Produce carbon monoxide

Use gasoline

Fill only when off

Do not back feed PG&E

324

# ELECTRICAL SAFETY

## Know how to turn off the power!

Install a disconnect switch

### CPR

Remove the power

Get help

CPR

### Current

1/500 of an Amp painful

1/10 of an Amp can be fatal

Heart stops

Disrupts the electrical functions of cells

Causes involuntary muscle contractions

No rings, bracelets

### Voltage

30 volts dangerous

No loose jewelry

## Capacitors hold a charge for a long time

Short them out after the power is off

### Fuse

Protects Circuit and You

Use the correct rating

325

### T0A02

**What health hazard is presented by electrical current flowing through the body?**

- A. It may cause injury by heating tissue
- B. It may disrupt the electrical functions of cells
- C. It may cause involuntary muscle contractions
- D. All of these choices are correct

### T0A04

**What is the purpose of a fuse in an electrical circuit?**

- A. To prevent power supply ripple from damaging a circuit
- B. To interrupt power in case of overload
- C. To limit current to prevent shocks
- D. All of these choices are correct

### T0A05

**Why is it unwise to install a 20-ampere fuse in the place of a 5-ampere fuse?**

- A. The larger fuse would be likely to blow because it is rated for higher current
- B. The power supply ripple would greatly increase
- C. Excessive current could cause a fire
- D. All of these choices are correct

326

**T0A08**

**Where should a fuse or circuit breaker be installed in a 120V AC power circuit?**

- A. In series with the hot conductor only
- B. In series with the hot and neutral conductors
- C. In parallel with the hot conductor only
- D. In parallel with the hot and neutral conductors

# POWER SUPPLIES

**12 VDC (13.8 V)**

New Radios

Great for mobile

Noise filter

“Power supply” 117VAC

Regulated to 13.8 Volts

Radios Don't Like Over  
Voltage

Use under size power supply +  
a gel-cell battery

Cost less

Works when the power fails

Transmitting draws a lot of  
power

Receiving draws minimal  
power

# Connectors

## UHF – PL259

Up to 150 MHz (BAD)

seal against water if outside

## N

Up to 10 GHz

seal against water if outside

## SMA

Small Threaded GHz

## DB 9

Computer

Newer Radios

## USB

Computer

## RCA - Phono

Audio

## Keyed Connectors

Prevent incorrect mating

## T9B06

Which of the following connectors is most suitable for frequencies above 400 MHz?

- A. UHF (PL-259/SO-239)
- B. Type N
- C. RS-213
- D. DB-25

## T9B07

Which of the following is true of PL-259 type coax connectors?

- A. They are preferred for microwave operation
- B. They are watertight
- C. They are commonly used at HF and VHF frequencies
- D. They are a bayonet-type connector

# MISC

**T7A02**

**What is a transceiver?**

- A. A device that combines a receiver and transmitter
- B. A device for matching feed line impedance to 50 ohms
- C. A device for automatically sending and decoding Morse code
- D. A device for converting receiver and transmitter frequencies to another band

**T8D10**

**Which of the following operating activities is supported by digital mode software in the WSJT-X software suite?**

- A. Earth-Moon-Earth
- B. Weak signal propagation beacons
- C. Meteor scatter

***D. All of these choices are correct***

All of the above answers a wrong 39 times  
and correct 18 times

If you don't know don't choose (D)

331

**T8A12 (B) This is a bad question**

**Which of the following is a disadvantage of FM compared with single sideband?**

- A. Voice quality is poorer
- B. Only one signal can be received at a time
- C. FM signals are harder to tune
- D. All these choices are correct

## The End?

**If You Feel Good With the Tech Questions.**

**Then the Next 48 Slides may Help You to Pass the General Test!**

KN6FW

332

## POWER LAW

$$P = E I$$

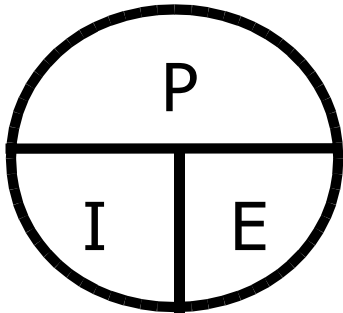

$$I = \frac{P}{E}$$
$$E = \frac{P}{I}$$

### OTHER FORMS

$$P = \frac{E^2}{R}$$

$$P = I^2 R$$

$$E = \sqrt{P R}$$

$$I = \sqrt{\frac{P}{R}}$$

## Peak Envelope Power

PEP is the RMS Power at max Modulation

Sneaky trick

---

G5B11

What is the ratio of peak envelope power to average power for an unmodulated carrier?

B. 1.00

G5B13

What is the output PEP of an unmodulated carrier if an average reading wattmeter connected to the transmitter output indicates 1060 watts?

B. 1060 watts

## Transformer Z

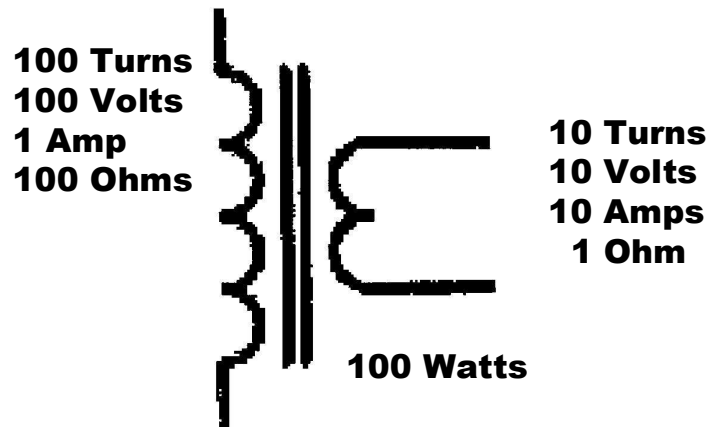

**Z Ratio = 100   Turns Ratio = 10**  
**Square root of 100 = 10**

### G5C07

What is the turns ratio of a transformer used to match an audio amplifier having 600 ohm output impedance to a speaker having 4 ohm impedance?

A. 12.2 to 1

## Impedance Matching 2

LC network

Pi-network

Transformer

Length of transmission line

---

### G5A11

Which of the following describes one method of impedance matching between two AC circuits?

A. Insert an LC network between the two circuits

### G5A13

Which of the following devices can be used for impedance matching at radio frequencies?

A. A transformer

B. A Pi-network

C. A length of transmission line

D. All of these choices are correct



# Solar Panels

**Sun required**

**Photovoltaic conversion**

**About 20% Efficient**

**About .5 Volts per Cell**

**Diode required to not discharge  
battery into dark panels**

---

**G4E08**

**What is the name of the process by which sunlight is  
changed directly into electricity?**

A. Photovoltaic conversion

**G4E09**

**What is the approximate open-circuit voltage from a  
fully illuminated silicon photovoltaic cell?**

B. 0.5 VDC

**G4E10**

**What is the reason that a series diode is connected  
between a solar panel and a storage battery that is  
being charged by the panel?**

B. The diode prevents self-discharge of the battery  
though the panel during times of low or no illumination

# Wind Power

**Good source of high power**

**Noise**

**The wind is unpredictable**

**Need battery back-up**

---

**G4E11**

**Which of the following is a disadvantage of using  
wind as the primary source of power for  
an emergency station?**

C. A large energy storage system is needed to supply  
power when the wind is not blowing

# Peak Inverse Voltage

The Voltage Across A Diode B4  
it smokes

## Half-wave power supply

2X Output Voltage

The Voltage on the Filter + AC

## Full-wave power supply

2 Diodes in series

1X Output Voltage

---

### G7A04

What is the peak-inverse-voltage across the rectifier in a half-wave power supply?

D. Two times the normal peak output voltage of the power supply

### G7A03

What is the peak-inverse-voltage across the rectifiers in a full-wave bridge power supply?

D. Equal to the normal peak output voltage of the power supply

# Switching Power Supply

## Uses High Frequency

About 100 KHz

More Efficient

Smaller

Smaller Parts

Needs Better Caps

Low Series Resistance

---

### G7A08

Which of the following is an advantage of a switchmode power supply as compared to a linear power supply?

C. High frequency operation allows the use of smaller components

# Neutralization

**Stops Self-oscillations**  
**Negative Feedback**

---

**G7B13**

**What is the reason for neutralizing the final amplifier stage of a transmitter?**

B. To eliminate self-oscillations

# POWER LAW

$$\mathbf{P = E I}$$

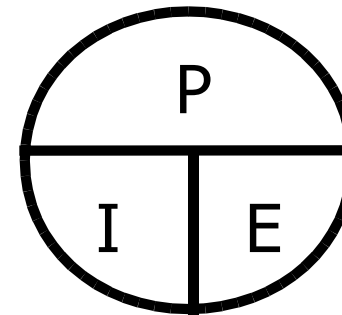

$$I = \frac{P}{E}$$
$$E = \frac{P}{I}$$

## OTHER FORMS

$$P = \frac{E^2}{R}$$

$$P = I^2 R$$

$$E = \sqrt{P R}$$

$$I = \sqrt{\frac{P}{R}}$$

# Oscilloscope

Vertical = Voltage

Horizontal = Time

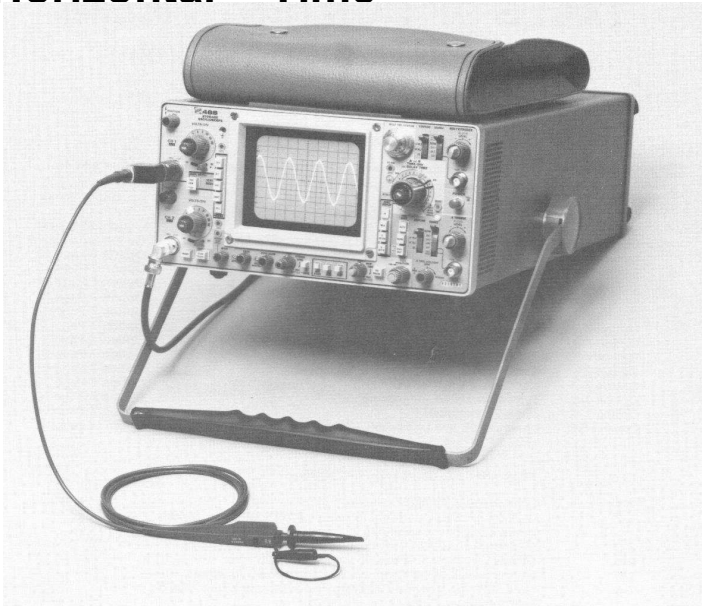

**G4B01**

What item of test equipment contains horizontal and vertical channel amplifiers?

D. An oscilloscope

# Integrated Circuits 2

## Digital

- TTL
  - Older
  - + 5 volt
- CMOS
  - Low power
  - Fast

---

**G6B03**

Which of the following is an advantage of CMOS integrated circuits compared to TTL integrated circuits?

- A. Low power consumption
- B. High power handling capability

*Some CMOS also have higher power handling capability*

**BAD QUESTION** 74AC series + or - 24 mA

74TTL series + .8mA , - 16mA

Answer is A but B is true also

# Memory

- **Non-volatile**
  - **Does not forget**
  - **Flash**
- **ROM**
  - **Read only memory**
  - **EEPROM**

## G6B05

What is meant when memory is characterized as non-volatile?

- C. The stored information is maintained even if power is removed

## G6B04

What is meant by the term ROM?

- B. Read Only Memory

# Gates

A	B	C
0	0	1
0	1	0
1	0	0
1	1	0

A	B	C
0	0	1
0	1	1
1	0	1
1	1	0

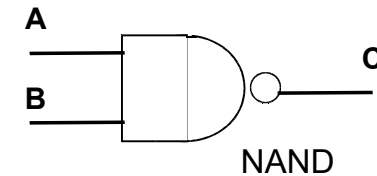
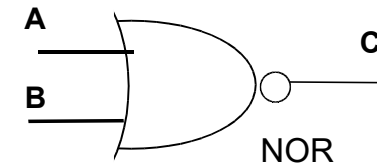

## G7B03

Which of the following describes the function of a two input AND gate?

- B. Output is high only when both inputs are high

## G7B04

Which of the following describes the function of a two input NOR gate?

- C. Output is low when either or both inputs are high

## DECIMAL BINARY

0	0000
1	0001
2	0010
3	0011
4	0100
5	0101
6	0110
7	0111
8	1000
9	1001
10	1010
11	1011
12	1100
13	1101
14	1110
15	1111

## Flip - Flop

2 State device

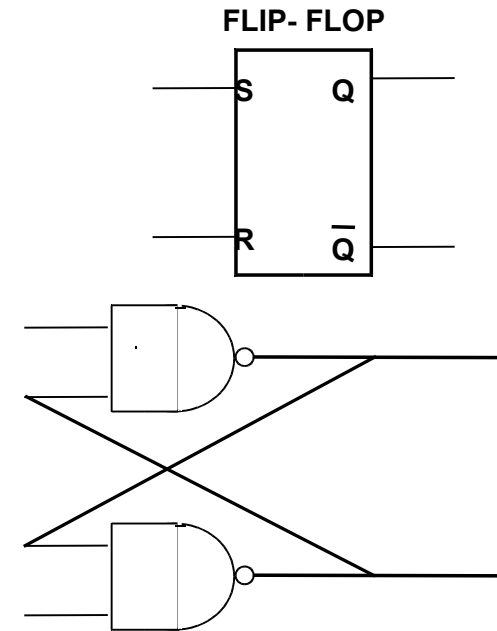

# Binary Counter

Binary 0-1 or on – off

3 Bit counter has 8 states

$$2^3 = 8$$

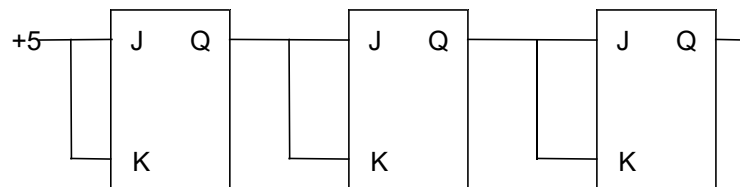

**G7B02**

Which of the following is an advantage of using the binary system when processing digital signals?

- A. Binary "ones" and "zeros" are easy to represent by an "on" or "off" state

**G7B05**

How many states does a 3-bit binary counter have?

- C. 8

# Shift Register

Moves data 1 step at a time

Serial to parallel converter

Bucket brigade

---

**G7B06**

What is a shift register?

- A. A clocked array of circuits that passes data in steps along the array

# International Telecommunications Union

## Frequency use in Regions

Wavelength band	ITU Region 1	ITU Region 2	ITU Region 3
<i>MF</i>	<i>kHz</i>		
160 m	1810-1850	1800-2000	1800-2000
<i>HF</i>	<i>MHz</i>		
80 m	3.50-3.60	3.50-3.60	3.50-3.60
75 m	3.60-3.80	3.60-4.00	3.60-3.90
40 m	7.0-7.2	7.0-7.3	7.0-7.2
30 m	10.10-10.15	10.10-10.15	10.10-10.15
20 m	14.00-14.35	14.00-14.35	14.00-14.35
17 m	18.068-18.168	18.068-18.168	18.068-18.168
15 m	21.00-21.45	21.00-21.45	21.00-21.45
12 m	24.89-24.99	24.89-24.99	24.89-24.99
10 m	28.0-29.7	28.0-29.7	28.0-29.7

### G1A14 [97.301(d)]

In what ITU region is operation in the 7.175 to 7.300 MHz band permitted for a control operator holding an FCC issued General Class license?

B. Region 2

## Power Out

Most band 1500 Watts PEP

100 Watts ERP referred to a dipole antenna on  
60 Meters

Any other Antenna must be logged and not  
Exceed 100 W ERP

200 Watts PEP on 30 Meters - 10 MHz

100 Watts on Beacons

Use only power required Communicate

Check FCC rules for other limits

### G2D07 [97.303(i)]

Which of the following is required by the FCC rules  
when operating in the 60-meter band?

A. If you are using other than a dipole antenna, you must  
keep a record of the gain of your antenna



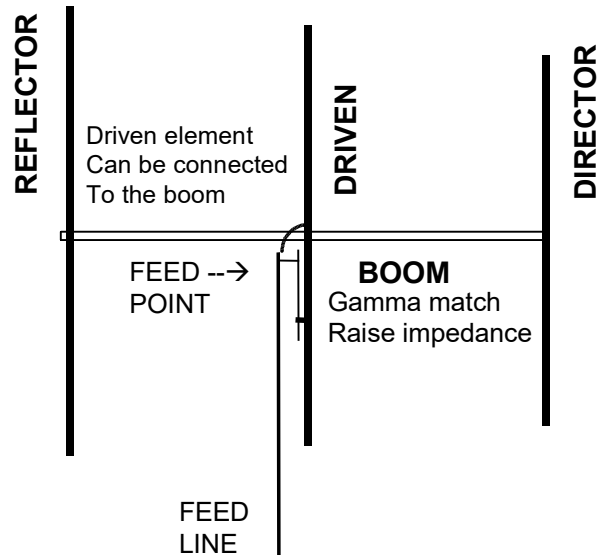

**G9C11**

**What is the purpose of a gamma match used with Yagi antennas?**

- A. To match the relatively low feed point impedance to 50 ohms

**G9C12**

**Which of the following is an advantage of using a gamma match for impedance matching of a Yagi antenna to 50 ohm coax feed line?**

- A. It does not require that the elements be insulated from the boom

## Yagi's Can Be Stacked

**About 3 dB Gain**

**More Gain Means Tighter Beam Width**

**G9C09**

**How does the gain of two 3-element horizontally polarized Yagi antennas spaced vertically 1/2 wavelength apart typically compare to the gain of a single 3-element Yagi?**

- B. Approximately 3 dB higher

**G9D05**

**What is an advantage of vertical stacking of horizontally polarized Yagi antennas?**

- D. It narrows the main lobe in elevation

# Log Periodic Antenna

**Wide Bandwidth**

**Less Gain than a Yagi**

**All Elements Driven**

**Element Lengths logarithmic**

---

**G9D06**

**Which of the following is an advantage of a log periodic antenna?**

A. Wide bandwidth

**G9D07**

**Which of the following describes a log periodic antenna?**

A. Length and spacing of the elements increase logarithmically from one end of the boom to the other

KN6FW

355

# HF Mobile Antennas

**Ground ?**

The Car

**Length**

Loaded

Narrow Bandwidth

**Corona Ball**

Tip of antenna

High voltage point

---

**G4E02**

**What is the purpose of a corona ball on a HF mobile antenna?**

D. To reduce high voltage discharge from the tip of the antenna

**G4E05**

**Which of the following most limits the effectiveness of an HF mobile transceiver operating in the 75-meter band?**

C. The antenna system

**G4E06**

**What is one disadvantage of using a shortened mobile antenna as opposed to a full size antenna?**

C. Operating bandwidth may be very limited

KN6FW

356

# OPEN LINE

- **Balanced**
  - 300 Ohms and up
  - **Impedance Controlled By**
    - **Diameter of Conductors**
    - **Space Between Conductors**
- **Low loss**
  - Can be effected by weather
- **Must be isolated from other conductors**
- **May require an impedance match**
  - Balun to match standard 50 ohm unbalanced coax
  - Located at the antenna
- **Can radiate a signal**

## G9A01

Which of the following factors determine the characteristic impedance of a parallel conductor antenna feed line?

A. The distance between the centers of the conductors and the radius of the conductors

## G9A03

What is the characteristic impedance of flat ribbon TV type twinlead?

D. 300 ohms

# SEPARATION Between Stations

**About same or a bit more  
Than the bandwidth of the signal**

---

## G2B04

When selecting a CW transmitting frequency, what minimum separation should be used to minimize interference to stations on adjacent frequencies?

B. 150 to 500 Hz

## G2B05

What is the customary minimum frequency separation between SSB signals under normal conditions?

B. Approximately 3 kHz

# Amateur Auxiliary “COPS” “OO”

---

## G2D01

What is the Amateur Auxiliary to the FCC?

A. Amateur volunteers who are formally enlisted to monitor the airwaves for rules violations

## G2D02

Which of the following are objectives of the Amateur Auxiliary?

B. To encourage self-regulation and compliance with the rules by radio amateur operators

## G2D03

What skills learned during hidden transmitter hunts are of help to the Amateur Auxiliary?

B. Direction finding used to locate stations violating FCC Rules

## General HF Frequencies

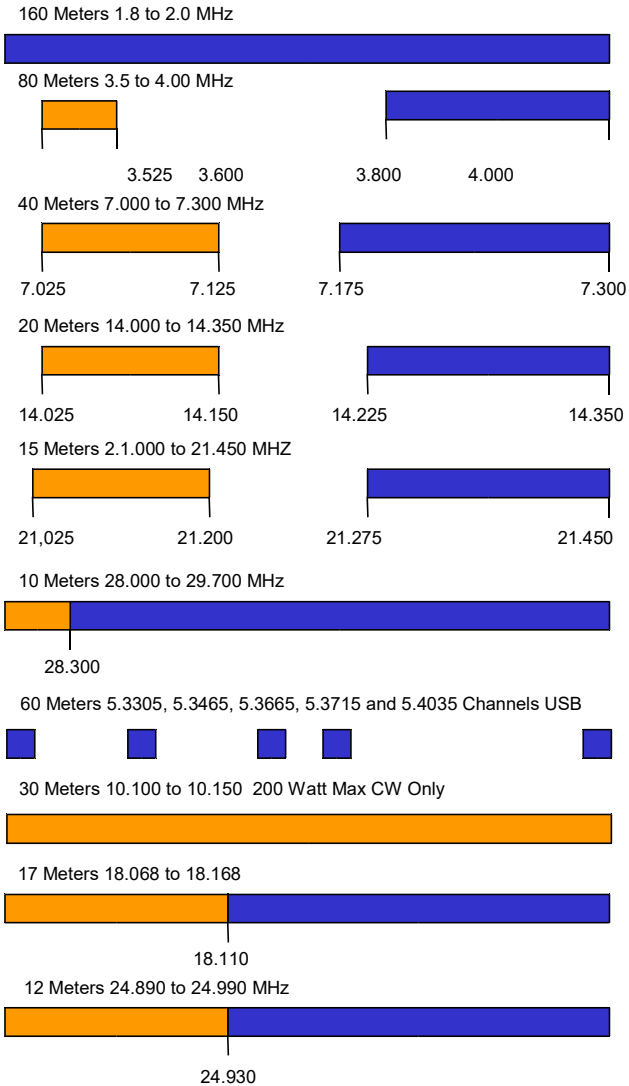

## General Bands 80,40,20,15

Never start with .000  
Phone band ends at the upper band edge

Always missing a small piece of the band at the lower end of the CW and Phone sections

About 1/2 of the band is CW (the lower end)  
Bands are about .3 MHz to .5 MHz wide

### G1A11 [97.301]

When General Class licensees are not permitted to use the entire voice portion of a particular band, which portion of the voice segment is generally available to them?

B. The upper frequency end

### G1A01 [97.301(d)]

On which of the following bands is a General Class license holder granted all amateur frequency privileges?

C. 160, 60, 30, 17, 12, and 10 meters

### G1A02 [97.305]

On which of the following bands is phone operation prohibited?

B. 30 meters

# LOG

**Required Only if Antenna not a Dipole  
on 60 Meters**

**Helps if the FCC Asks ...**

**History of Contacts**

**Frequency, Time, Date and Call Sign**

---

## **G2D08**

**What is a reason why many amateurs keep a station log?**

D. To help with a reply if the FCC requests information

## **G2D09**

**What information is traditionally contained in a station log?**

A. Date and time of contact

B. Band and/or frequency of the contact

C. Call sign of station contacted and the signal report given

D. All of these choices are correct

# RF in the Shack

**BAD**

**Resonant Ground**

Keep Grounds Short

High Impedance

**Ground Everything (No Loops)**

---

## **G4C05**

**What might be the problem if you receive an RF burn when touching your equipment while transmitting on an HF band, assuming the equipment is connected to a ground rod?**

D. The ground wire has high impedance on that frequency

## **G4C06**

**What effect can be caused by a resonant ground connection?**

C. High RF voltages on the enclosures of station equipment

## **G4C07**

**What is one good way to avoid unwanted effects of stray RF energy in an amateur station?**

A. Connect all equipment grounds together

# Digital Signal Processor

**Very Fancy Filter**

**Bandwidths and Shapes**

**Remove Noise from Signal**

**Automatic Notching**

---

**G4C13**

**Which of the following can perform automatic notching of interfering carriers?**

B. A Digital Signal Processor (DSP) filter

**G4C11**

**Which of the following is a function of a digital signal processor?**

B. To remove noise from received signals

**G4C12**

**Which of the following is an advantage of a receiver DSP IF filter as compared to an analog filter?**

A. A wide range of filter bandwidths and shapes can be created

KN6FW

365

# Tuning a Tube Final

**Dip the Plate Current**

**Output Tuned to the Frequency**

**Increase the coupling to not exceed the Tubes Rating**

---

**G4A04**

**What reading on the plate current meter of a vacuum tube RF power amplifier indicates correct adjustment of the plate tuning control?**

B. A pronounced dip

**G4A08**

**What is the correct adjustment for the load or coupling control of a vacuum tube RF power amplifier?**

D. Maximum power output without exceeding maximum allowable plate current

KN6FW

366

# Two Tone Test

Two non-harmonically related  
Audio Signals

Used to check Linearity

---

**G4B15**

What type of transmitter performance does a two-tone test analyze?

A. Linearity

**G4B07**

What signals are used to conduct a two-tone test?

B. Two non-harmonically related audio signals

# Bandwidth Used

Depends on Modulation  
Check Band Edge

**USB**

About 3 kHz above the carrier

**LSB**

About 3 kHz below the carrier

**CW**

About 150 Hz about the carrier

---

**G4D08**

What frequency range is occupied by a 3 kHz LSB signal when the displayed carrier frequency is set to 7.178 MHz?

C. 7.175 to 7.178 MHz

**G4D09**

What frequency range is occupied by a 3 kHz USB signal with the displayed carrier frequency set to 14.347 MHz?

B. 14.347 to 14.350 MHz



# SUPERHETERODYNE RECEIVER DUAL

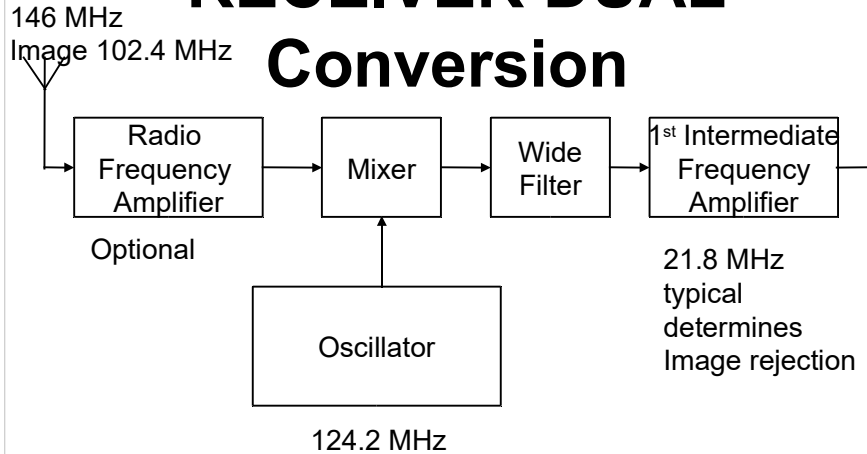

- **Basic part of any receiver**
- **Front End of “Most” Receivers**
- **Just add**
  - 2<sup>nd</sup> IF
  - Filters
  - Detector
  - Audio Stage

369

# CW – SSB RECEIVER

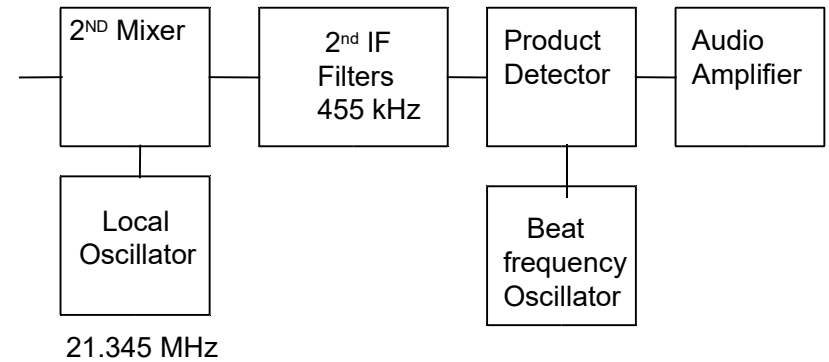

- **BFO inserts a signal to make a tone for CW**
- **BFO provides the carrier for SSB**
- **2<sup>nd</sup> IF Filter determine the bandwidth of the receiver**
- **Bandwidth of Filter to Match Mode**
  - Reduces signal to noise ratio

370

## FM RECEIVER

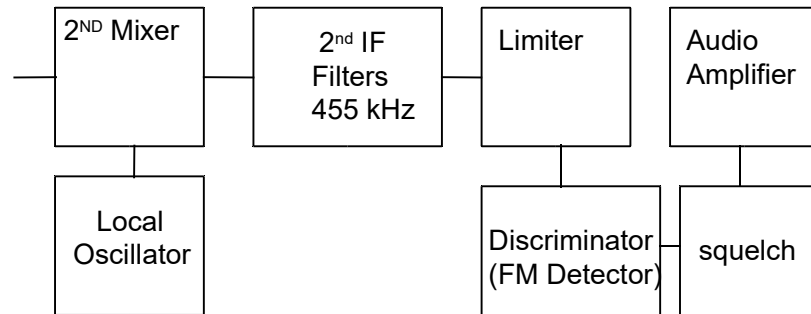

- **Limiter removes any amplitude changes**
  - Eliminates man made noise
- **Discriminator converts frequency change to audio**
- **Squelch mutes noise**

G7C08

What type of circuit is used in many FM receivers to convert signals coming from the IF amplifier to audio?

D. Discriminator

371

## AM RECEIVER

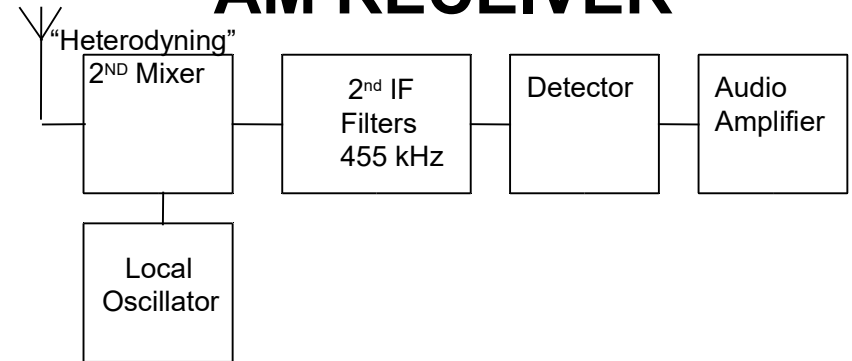

- **Antique method like CW with none of the advantages**
- **Uses about 2X bandwidth of SSB**
- **Is susceptible to noise**

G8B03

What is another term for the mixing of two RF signals?

A. Heterodyning

372

## Simple Superhetrodyne Receiver

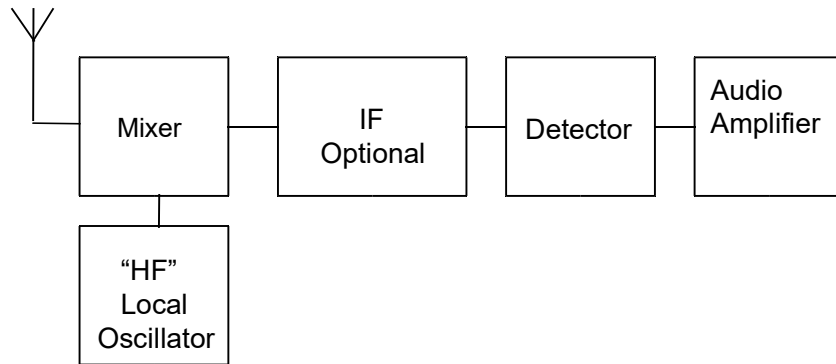

**G7C07**

**What is the simplest combination of stages that implement a superheterodyne receiver?**

C. HF oscillator, mixer, detector

373

## Software Defined Radio

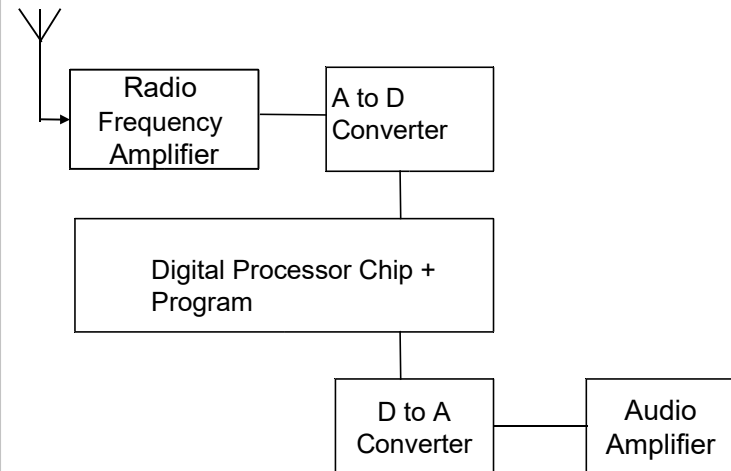

**G7C09**

**Which of the following is needed for a Digital Signal Processor IF filter?**

A. An analog to digital converter

B. A digital to analog converter

C. A digital processor chip

D. All of the these choices are correct

374

## SSB TX

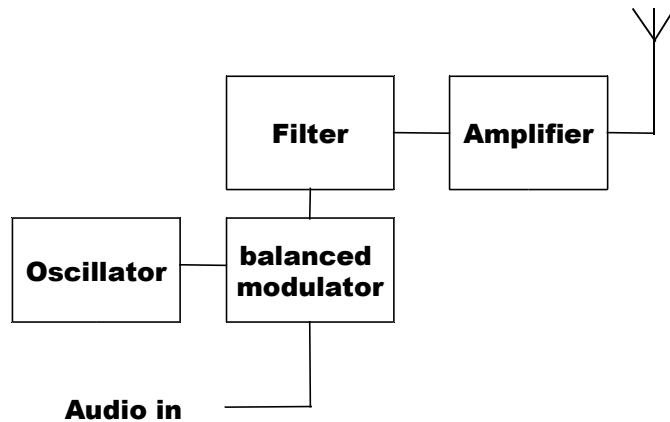

G7C01

Which of the following is used to process signals from the balanced modulator then send them to the mixer in some single sideband phone transmitters?

B. Filter

G7C02

Which circuit is used to combine signals from the carrier oscillator and speech amplifier then send the result to the filter in some single sideband phone transmitters?

D. Balanced modulator

375

## FM TX

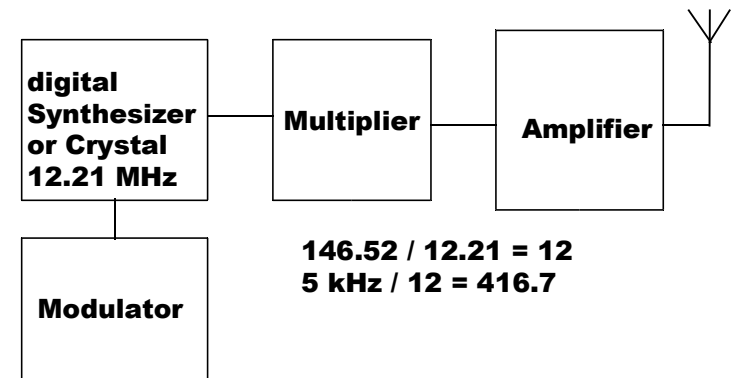

G7C05

Which of the following is an advantage of a transceiver controlled by a direct digital synthesizer (DDS)?

D. Variable frequency with the stability of a crystal oscillator

G8B07

What is the frequency deviation for a 12.21 MHz reactance modulated oscillator in a 5 kHz deviation, 146.52 MHz FM phone transmitter?

B. 416.7 Hz

376

# CW ... \_ ..\_ ..\_.

- AR = End Formal message
- RST with a C = Chirpy or unstable signal
- CL = Closing station
- K” = Any station transmit  
usually send  
at the end
- KN = Listening only for a specific station
- DX = Distant Station Outside the country
- “DE” = From or this
- 73 = Best regards or good-bye
- Send no faster than you can receive
- Zero Beat the station you want to talk to

## Spectrum Analyzer Waterfall Display

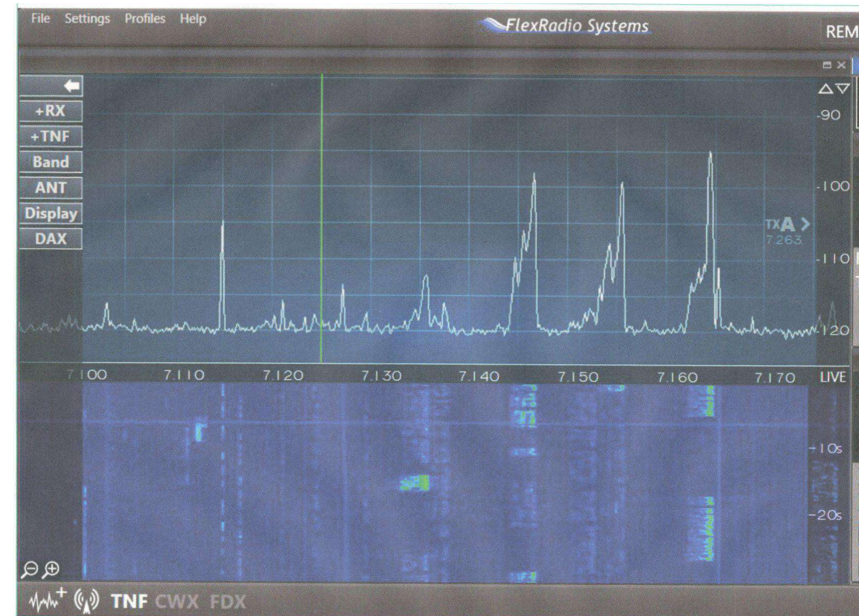

Slide Complements Don AI6RE

# Winlink

- Internet Connection
  - Send a Connect message on Frequency
- 

## G2E13

Which communication system sometimes uses the Internet to transfer messages?

A. Winlink

## G2E10

Which of the following is a way to establish contact with a digital messaging system gateway station?

D. Transmit a connect message on the station's published frequency

379

# Short – Long Path

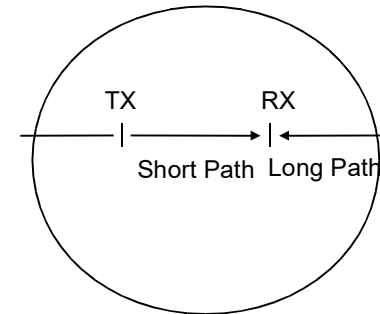

- Short path beam pointed E
  - Long path beam pointed W
    - Transmission time Longer
- 

## G3B01

How might a sky-wave signal sound if it arrives at your receiver by both short path and long path propagation?

D. A well-defined echo might be heard

## G2D06

How is a directional antenna pointed when making a "long-path" contact with another station?

C. 180 degrees from its short-path heading

380

## RFI from Your Car

- **Charging System**
    - Alternator Whine
  - **Fuel System**
    - Pump Motor
  - **On Board Computers**
    - Lots of them
- 

### G4E07

Which of the following may cause interference to be heard in the receiver of an HF radio installed in a recent model vehicle?

- A. The battery charging system
- B. The fuel delivery system
- C. The vehicle control computer
- D. All of these choices are correct

## Miscellaneous

### Interlocks

Keep you from killing yourself

Turn off power when door or cabinet is opened

### Lead

It's bad for you

It's in solder

---

### G0B10

Which of the following is a danger from lead-tin solder?

- A. Lead can contaminate food if hands are not washed carefully after handling the solder

### G0B12

What is the purpose of a power supply interlock?

- C. To ensure that dangerous voltages are removed if the cabinet is opened