

Oscilloscopes for Radio Amateurs

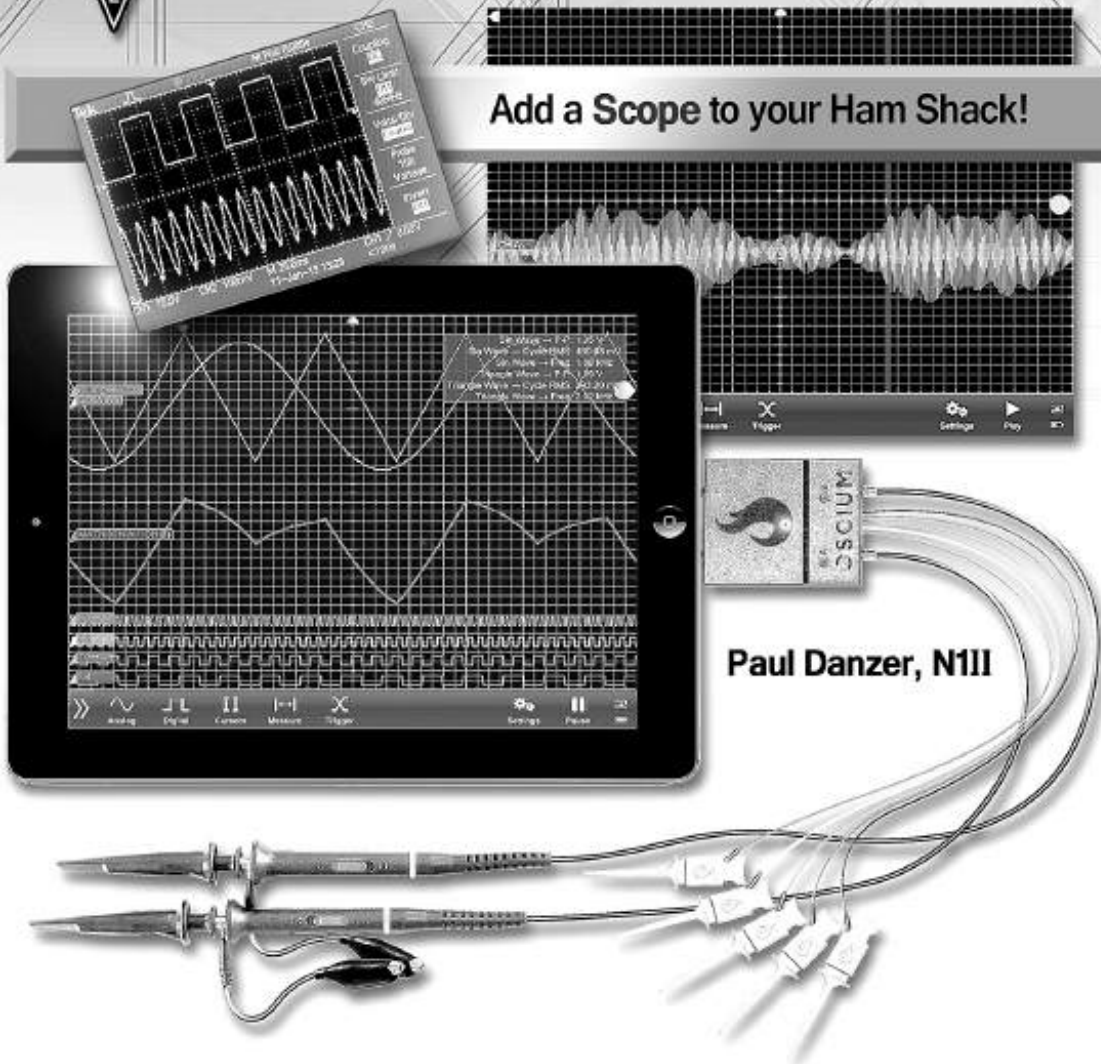

Add a Scope to your Ham Shack!



Paul Danzer, N1II

Production Staff: Michelle Bloom, WB1ENT, Production Supervisor, Layout
Jodi Morin, KA1JPA, Assistant Production Supervisor, Layout
Sue Fagan, KB1OKW, Graphic Design Supervisor, Cover Design
David Pingree, N1NAS, Senior Technical Illustrator

Copyright © 2015 by
The American Radio Relay League, Inc.

Copyright secured under the Pan-American Convention

All rights reserved. No part of this work may be reproduced in any form except

by written permission of the publisher. All rights of translation are reserved.

Printed in the USA

Quedan reservados todos los derechos

ISBN: 978-1-62595-023-9

First Edition

We strive to produce books without errors. Sometimes mistakes do occur, however. When we become aware of problems in our books (other than obvious typographical errors), we post corrections on the ARRL website. If you think you have found an error, please check www.arrl.org/notes for corrections. If you don't find a correction there, please let us know by sending e-mail to pubsfdbk@arrl.org.

eBooks created by www.ebookconversion.com

Contents

Foreword

Preface

Acknowledgements

About the Author

Dedication

- 1 Why Get an Oscilloscope?
- 2 A Little History
- 3 Every Scope Has These Elements
- 4 Probes and Accessories
- 5 Scope Sections in Detail
- 6 Input Modes
- 7 Let's Put a Scope to Work
- 8 If You Are Going to Buy One — Specifications

Appendix 1

Software Oscilloscopes — Capable and Free!

Appendix 2

QST Product Review: Tektronix TBS1042 and Rigol DS1052E Oscilloscopes

Appendix 3

QST Product Review: Oscium iMOS-204 Portable Oscilloscope

Foreword

A popular activity among amateurs is building, modifying, restoring or repairing equipment. During their careers, amateurs assemble a home workshop appropriate for their interests, usually starting with a few basic tools, a good soldering iron and perhaps a multimeter. From there, you might add a power/SWR meter or an antenna analyzer.

When it comes to working inside a piece of equipment, one of the most useful tools is the oscilloscope. "Scopes" have been around for decades, helping countless amateurs "see" the signals inside their equipment. Is

my SSB transmitter properly adjusted? What does my CW waveform look like? Is there ripple on my power supply? Once an expensive tool for only the most technically savvy amateur, today we have access to a variety of analog, digital or hybrid scopes at prices suitable for a home workshop.

In this book, Paul Danzer, N1II, conveys a wealth of information about these useful tools. Starting with an overview and short history lesson, Paul goes on to discuss oscilloscope functional blocks, probes, controls and input modes and then describes practical applications. He concludes with a chapter to help you understand scope specifications and features so that you can find one that will best suit your needs.

We hope you'll find this book a useful addition to your library.



David Sumner, K1ZZ
Chief Executive Officer
Newington, Connecticut
February 2015

Preface

As every teacher knows, occasionally you are rewarded by a few students who want to know a bit more on a topic that your lecture or the textbook covered. This is especially true when you mention to a class, as I did, that the oscilloscope is a very valuable tool in electronics — ham radio or otherwise — simply because it lets you “see” what is going on!

Years ago the same oscilloscope block diagram and the same explanation were found in most books. Today, with the introduction of personal computers, digital technology and the ability to produce oscilloscopes with more capability at a lower cost, the entire field has changed.

In particular, there still are quite a few totally analog oscilloscopes available, but there are also many new configurations. Some are totally self-contained digital instruments, some are a digital/analog hybrid, some require a personal computer to act as the processor and display, and others use smartphones phones and tablets as their host.

Most books and online descriptions reflect either the old analog configuration or advanced theory beyond what many students and radio amateurs can profitably use. This book was written to discuss oscilloscopes in a middle ground — past the simple analog scope, but less than a graduate level treatise in data processing and signal computations.

Today's technologies have made very capable oscilloscopes available to radio amateurs for many uses in the ham shack. There are two reasons for this availability. First, the new digital scopes have displaced the older, very expensive scopes in businesses and industrial labs. As a result, scopes with capabilities most of us could only dream of years ago are often available used at a price of one tenth or less of their original price. Second, the new digital scopes are, due to the use of digital processing, not dependent on precision analog circuits and therefore less expensive than their predecessors.

The result is that the ability to “see what is going on” in our equipment is much more available and much more common in the ham shack.

73, Paul Danzer, N1II

(past call signs: KN2DGR, K2DGR, W1DQJ)

Acknowledgements

Many thanks to the following individuals, companies and organizations who were very generous with their time and help:

Jim Brannigan, WB2TPS

Dave Cisco, W4AXL

Sam Dick, NV1P

Seth Golitzer, W1SHG

Don Hudson, KA1TZR

Chuck Penson, WA7ZZE

Ron Pollack, K2RP

Rich Roznoy, K1OF

Joe Veras, K9OCO

Tim Walker, W1GIG

Mark Wilson, K1RO

Alex Wong at Digilent Inc.

Bryan Lee at OSCIUM, Dechnia, LLC

Chuck at www.myvintage.tv

Tekwiki, the community of Tektronix oscilloscope enthusiasts, www.w140.com/tekwiki

About the Author

Paul Danzer, N1II, started his Amateur Radio career as a teenager, which led to Bachelor's and Master's Degrees in Electrical Engineering. His engineering career spanned more than 30 years, and he was awarded 11 patents while specializing in digital circuits, digital systems, and radar systems. As a result he had a great deal of hands-on experience with the subject of this book, oscilloscopes.

After retiring from engineering, he spent three years as a Technical Editor at ARRL Headquarters in Newington, Connecticut. There, he authored one book, co-authored a second and edited the *ARRL Handbook* and the *ARRL Operating Manual* as well as several other publications.

Paul then embarked on a new career as a Professor of Computer Science at a local community college, teaching electronics, personal computer hardware, data communications and other PC related subjects. After 11 years as a full time professor he is now an Adjunct Professor and spends the rest of his time writing on Amateur Radio subjects.

He has written more than 250 magazine articles for Amateur Radio publications and computer publications. His ARRL appointments include TA (Technical Advisor) and TS (Technical Specialist). In 2004, he was awarded the Bill Orr, W6SAI Technical Writing Award by the ARRL Board of Directors.



Dedication

To my wife Flo, who has patiently tolerated strange noises, strange wires, and all sorts of strange things attached to the roof of our home.

Chapter 1

Why Get an Oscilloscope?

Didn't you ever say, "I wish I could see what was going on?"

That is the question hams have been asking since the earliest days of ham radio. By nature, not only do hams like to experiment, but they also want to get the most out of their equipment. Can you imagine a cook, busy preparing a meal, who cannot smell or taste the food? That is exactly the situation many hams find themselves in when they are testing, repairing or just using their gear.

Every piece of test equipment has its place, and an on-the-air test can be very revealing. But to really understand what is going on — just like a cook in the kitchen has to taste dishes with his or her tongue — you have to literally see with your eyes to really understand a circuit or equipment.

Some years ago this ability to see was beyond the budget of most hams, except for a few who built their own oscilloscopes. Professional-grade scopes cost \$1500 to \$3500 and required periodic calibration with test equipment that was more expensive than the scopes themselves. Industrial surplus equipment or lesser grade scopes, including kits, were not cheap. You would have to write a check for \$300 to \$600 and you were never sure just how accurate your measurements were.

In addition to requiring periodic calibration, this generation of scopes used vacuum tubes that ran hot, increased the amount of and frequency of calibration, and increasingly caused the oscilloscopes to deteriorate in performance.

Since those days there have been two major changes: Solid state devices (transistors, diodes, integrated circuits) have replaced vacuum tube circuitry and digital techniques have replaced drifting analog circuits. Perhaps the result of these changes can best be seen by comparing the pictures in this chapter.

What Do Oscilloscopes Old and New Look Like?

The older generation high-quality analog scope, such as the Tektronix unit shown in **Figure 1.1**, represents a type of scope that was a laboratory standard through many model number variations. Generally these scopes weighed more than 60 pounds and were mounted on a cart because they were not carried easily. Power input was about 700 W, so a small lab space could get quite hot. You can see the tube lineup of this beast in **Figure 1.2**.

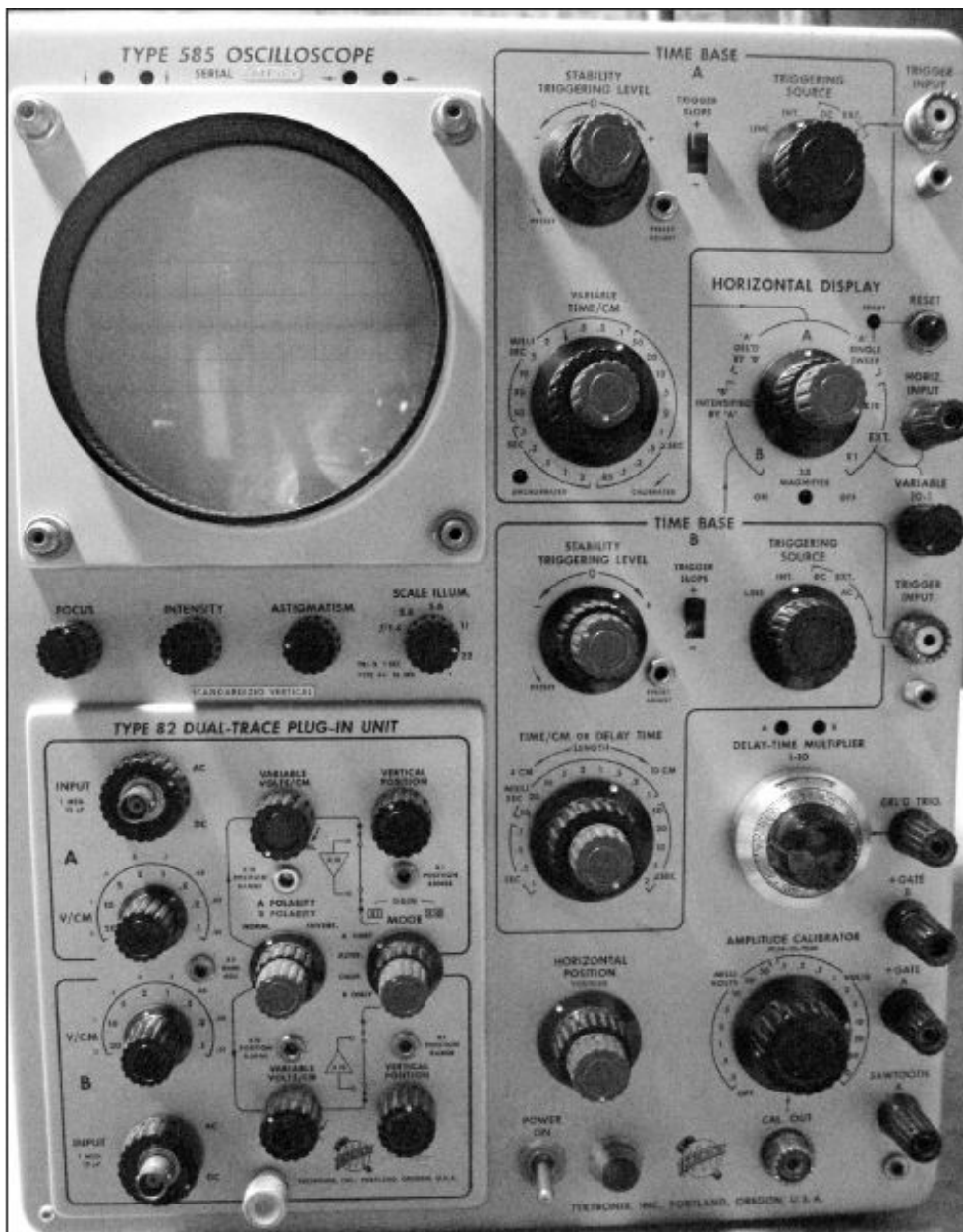

Figure 1.1 — A standard Tektronix oscilloscope. It was large, heavy and ran hot. Various similar units were found in almost every industry laboratory. [Photo courtesy of Sam Dick, NV1P]

Technician quality scopes such as might be found in a well-equipped (and well-funded) home lab or on the bench of a TV repair shop in the past typically looked like the one in **Figure 1.3** — an EICO 460. For the most part these scopes did not do precision measurement as the Tektronix did, but still answered the question “What is going on?” In the case of the TV repair shop or the ham workshop, it answered the question “Is the signal there?”

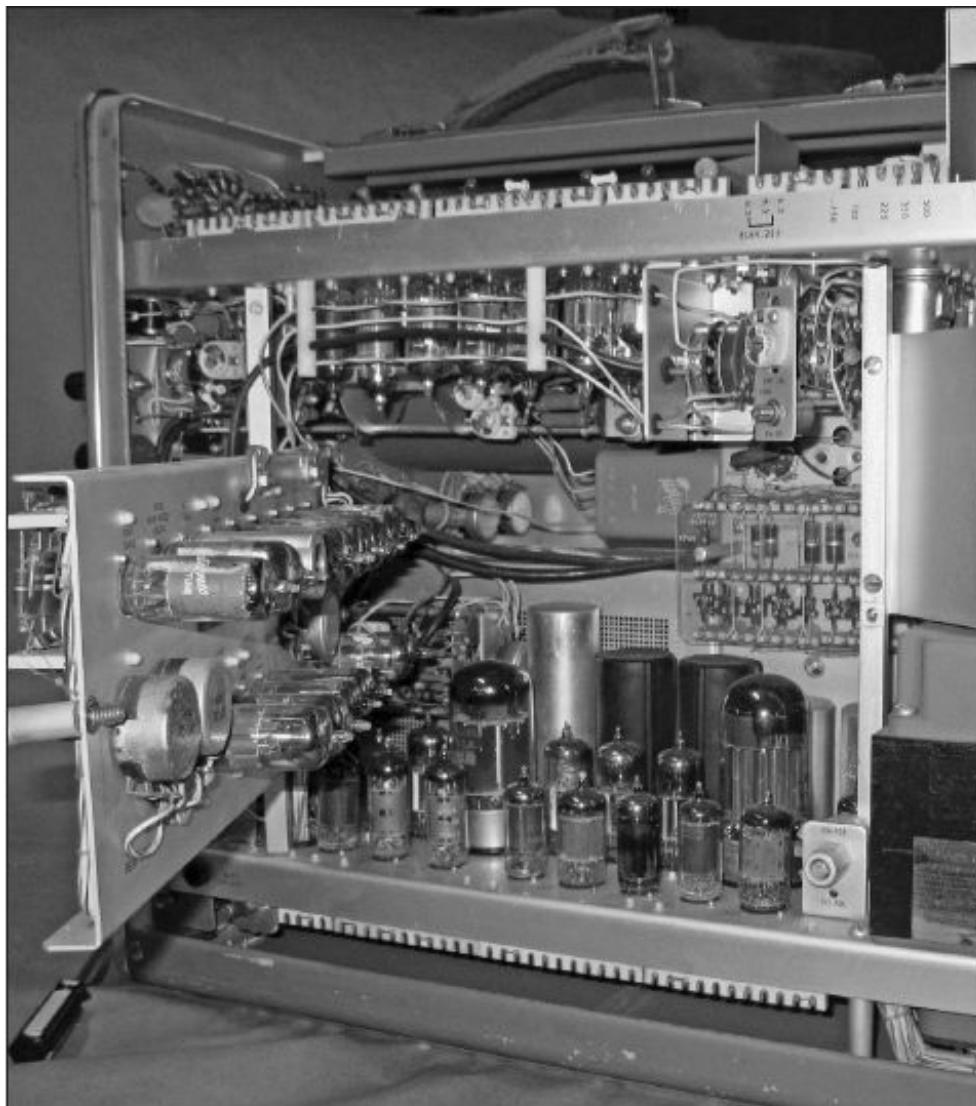

Figure 1.2 — Here you can see why the Tektronix tube scopes ran hot and consumed a great deal of space and power. This picture shows only part of the tube lineup.



Figure 1.3 — At one time an EICO scope was a lower cost alternative to the much more expensive Tektronix. Units such as this were found in many TV repair shops and some ham workshops. [Photo courtesy of Tim Walker, W1GIG]

By comparison, many of today’s scopes look like the one **Figure 1.4**. It measures roughly $2 \times 8 \times 7$ inches, weighs 1.5 pounds, and plugs into a computer USB port for power. Except for the input circuit, the rest of the scope is digital. There is no screen or display; the scope feeds a desktop or laptop computer. Calibration is usually built in, and the digital circuits are often given additional tasks such as acting as a signal generator or a spectrum analyzer. The most amazing part is the cost — anywhere from less than \$100 to perhaps \$350 for fairly accurate measurements.

There is one other major change from the older analog oscilloscopes to the newer digital scopes. Often the scope is used to find out “What Happened?” This means looking for something that happens briefly, not continuously. With older analog scopes, their native mode of operation was continuous measurement. You would have to watch the display carefully to catch transient or “occasionally here, usually not” things. To be able to capture and hold transient measurements, you would need to own an even more expensive *storage scope*. Storage scopes could capture and display a transient waveform on a special phosphor screen that had long-term holding capability.



Figure 1.4 — Today's oscilloscopes look more like this. This one is small, fairly low cost and very capable, though it requires a computer and accompanying software for processing, control and display of measured waveforms.

The native mode of the new digital scope is storage. Input waveforms are sent to a digital memory. Unless commanded to erase or replace the old data with new data, they automatically store their inputs to the limit of the size of their memory.

What Can You Do With Your Scope?

Later on, in Chapter 7, we will take a look at many of the common uses of an oscilloscope in the ham shack. But for now, let's just get an idea of what these devices can do for you.

If you opened a copy of the *ARRL Handbook* of 30 or 40 years ago, the first application for scopes would be to look at your transmitted AM signal. This was a very good way to tell if you had your transmitter adjusted correctly or if you were *over modulating*, thus spattering all over the band in addition to sounding terrible. In Chapter 7 we will take a look at this application, but for now look at the block diagram in **Figure 1.5**. Here is a problem your scope could help you with, and at least tell you what is going on.

Suddenly your friends on the repeater complain that your 2 meter transceiver at home has a terrible hum. Because you are conscious of public service and emergency communications, you run this radio from a 12 V storage battery with a trickle charger. You can think of three possibilities.

First, is the hum coming from the trickle charger/battery combination? Out comes your scope, you connect it at point A, from the +12 V line to ground, and this possibility is quickly confirmed or eliminated. Is the 12 V line a pure dc signal or is there an ac component to the waveform?

Next, is the problem in the audio chain? Perhaps it is a bad microphone cord or something in the microphone amplifier. Connect the scope to point B and now you can tell if the hum is coming from this set of circuits.

Finally, perhaps the synthesizer/phase-locked loop is having a problem. Your friends tell you that the hum sounds like 60 Hz, so look at various places around the synthesizer. You don't have to know what waveform you are looking at, nor do you need to see each individual signal in detail. Look for an envelope that has repetitive changes corresponding to the approximate period of a 60 Hz waveform — perhaps at point C.

Is this approach guaranteed to help you solve the problem? Of course not, but you can actually *see* what is going on at these key points in the circuit, so you stand a better chance of finding a cure. Maybe you will be lucky and it is just a bad ground on your microphone cord.

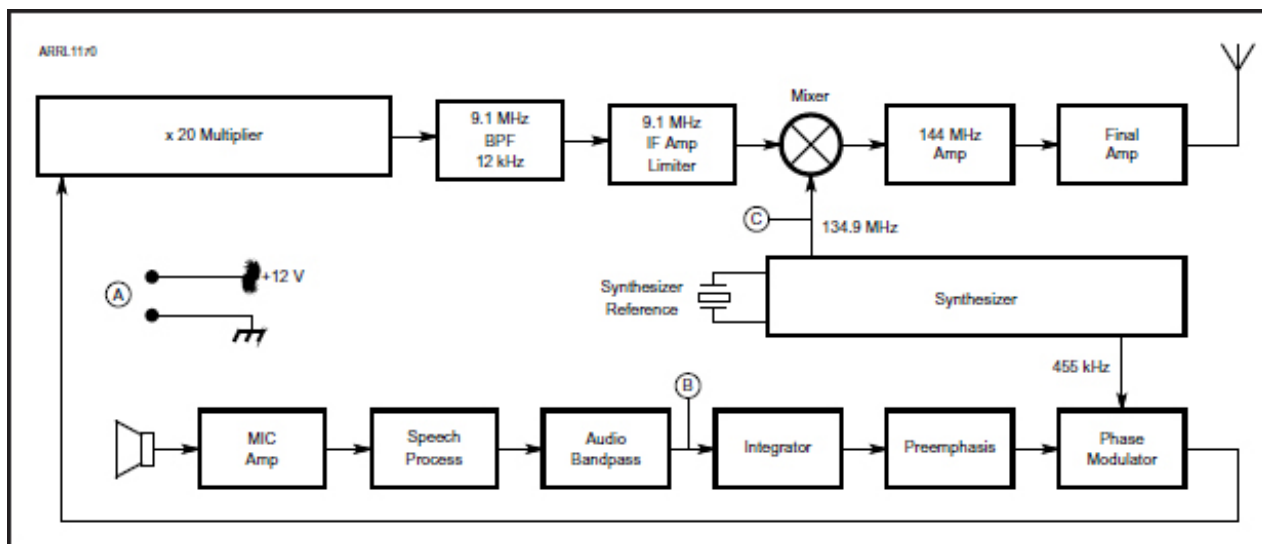

Figure 1.5 — Block diagram of a typical 2 meter transceiver. A scope can come in handy for troubleshooting problems, even when you are not sure what the correct waveforms should be.

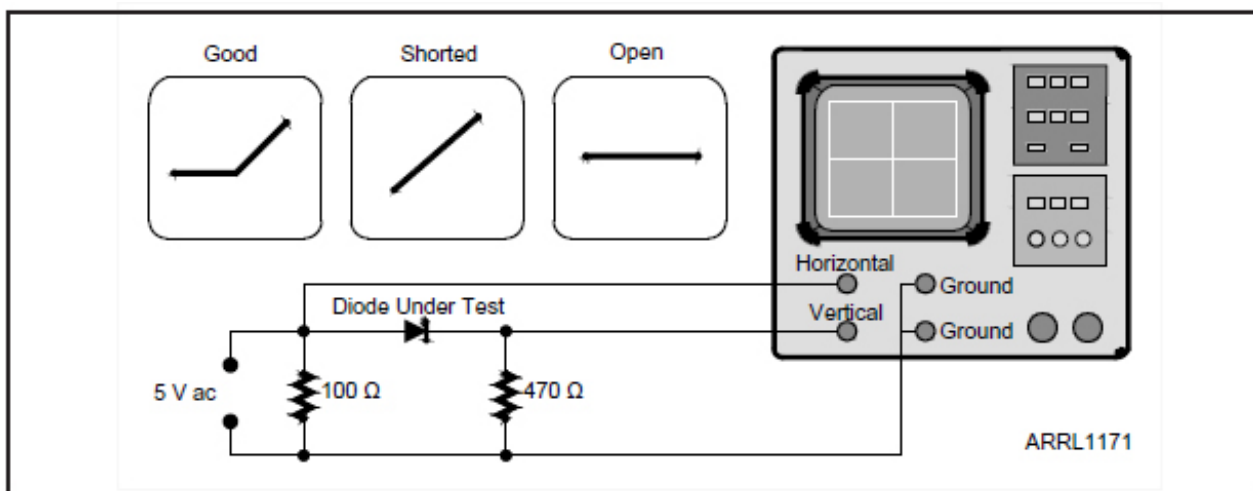

Figure 1.6 — The addition of a few components can turn a scope into a special-purpose test instrument.

Figure 1.6 shows another very common use for oscilloscopes. With a few more components you can test diodes, capacitors, resistors, and transistors. In Chapter 7 we will discuss this use and others in more detail. In **Figure 1.6**, the component being tested is a standard diode — perhaps a power rectifier. By picking the correct components and oscilloscope settings, a V-I (voltage vs current) curve appears on the scope display. If the diode is okay, the V-I curve will look like the left-hand drawing, if shorted, the center drawing, and if open the right-hand drawing.

An oscilloscope in your shack is more than just a handy test instrument; it lets you both solve problems and test new ideas. Chapter 2 will explain a bit of where oscilloscopes came from and how the inexpensive but very capable units we have today were developed for the older — occasionally very much older — technology.

Chapter 2

A Little History

We've come a long way. In order to understand why oscilloscopes have the designs and capabilities they have today, it is helpful to see where they came from and how they developed. In the next chapter you will see that every oscilloscope — whether it is built entirely in hardware, partly in hardware and partly in software or even totally in software — has the same four elements or sections. One reason for this commonality is history.

The changes in oscilloscopes from the late 1800s to the present result from a two-edged sword. As the technology changed, the requirements for oscilloscopes changed and the components that could be used in the design of oscilloscopes changed — both factors changing in parallel. This chapter summarizes how the oscilloscopes we have available to us in our ham shacks and workbenches developed and changed over the years. A full history would occupy more than this entire book, but a brief glance serves to explain where we are and how we got here. In particular, this chapter explains how hams have gone from rarely owning and using oscilloscopes to being able to afford and use today's commonly available low-cost scopes if they so desire.

Early Instruments

The need to “see” a voltage, current or other physical item dates back to the earliest electrical design. It would come as no surprise that the limit to “seeing” was how fast the measuring instrument could respond, how fast you could see the response, and perhaps most important — how fast you could write it down.

Very quick mechanical “scribers” — what today we would call plotters — were invented. As **Figure 2.1** shows, a typical early model consisted of a modified meter such as a standard D'Arsonval voltmeter with an extended pointer. On the end of the pointer was either a pen with a roll of paper or a metal pin or scribe that left an impression on a treated paper. The meter is mounted over the paper. The motion of the pen provides the X-axis (amplitude of the voltage being measured), and the paper motion provides the Y-axis (time scale). In this crude implementation, the amplitude scale is not linear, and various clever mechanical ways were invented to make it linear.

Since the meter pointer does not move very quickly, other measurement techniques were found. Some used mirrors and light on photographic sensitive paper to allow the instrument to be more responsive and to plot higher frequency signals.

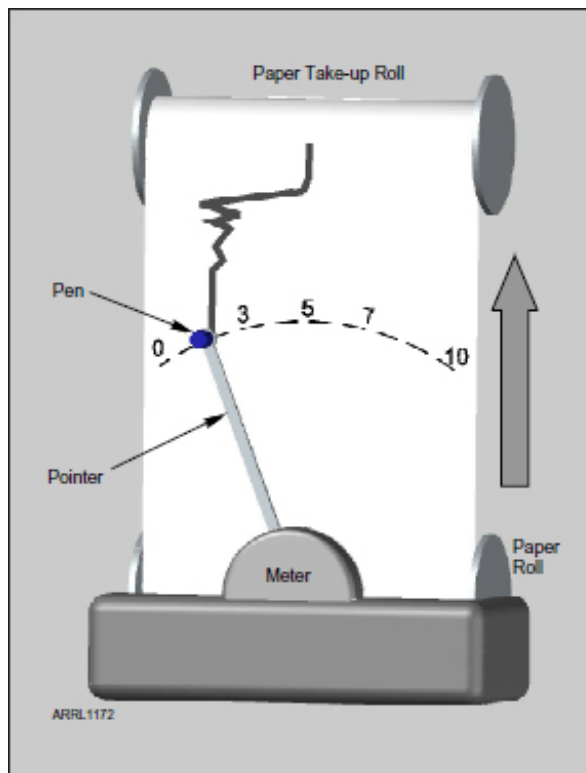

Figure 2.1 — A basic plotter, the predecessor to the oscilloscope. The paper moves under the pen of metal scribe so the trace shows the voltage or current as it changes. At zero volts the pen is on the left edge of the paper, and higher voltage moves the pen further to the right. The paper rolling along corresponds to the time axis.

The Cathode Ray Tube (CRT) Changed Everything

It is always a problem to state with absolute certainty who was the first person to do something or the first person to invent something. As an example, the Smithsonian in Washington DC has an entire exhibit paying tribute to the Wright Brothers for making the first flight. But in Connecticut there is a record of an earlier flight, described in a newspaper of the time. The French have their own candidate for first flight, as do the Germans and others.

Knowing that, let's start with Karl Braun, who is credited with making a cold-cathode ray tube in 1897, and is recorded as using it to explore the waveform of an alternating current voltage. Thus, in effect, he made and used an oscilloscope. However, this was before the first recorded vacuum tube amplifier demonstrated by Sir John Ambrose Fleming in 1912. Undoubtedly there are other candidates to claim that they should have the "first to do" title of these developments, but these things do form the basis of today's oscilloscopes.



Figure 2.2 — The basic controls on this very early commercial oscilloscope, sold by National Radio, are recognizable today. [Photo courtesy of Chuck at myvintagetv.com]

Fast forwarding now to pre-World War II, **Figure 2.2** shows a state-of-the-art oscilloscope for hams in 1937. This device, the National Radio Company model CRM, would be recognized as a functional piece of test equipment that could be used by most hams today — although of limited bandwidth and accuracy. The price, as advertised in *QST* in the late 1930s, was — ready for this one? — \$11.10 plus an additional \$5.81 for the cathode ray tube.



Figure 2.3 — After World War II, National came out with a new scope, featuring a larger tube. [Photo courtesy of Chuck at myvintagetv.com]

By 1947 hams had graduated to the National CRU oscilloscope, with a 2-inch tube (**Figure 2.3**). From the picture it seems to have a sweep trigger control. At the same time, World War II surplus gear was very common, so many hams were building their own version of the National scope. Then the Heath Company, which started out in life selling airplane kits, came out with its first electronic kit — the O-1 oscilloscope. Key to this kit was, as you might guess, the large stock of war-surplus cathode ray tubes available on the market. **Figure 2.4** is an early Heathkit scope kit selling for \$39.50.



Figure 2.4 — Heath came on the scene with a low priced kit, directly aimed at hams and electronic hobbyists. The original model, O-1, and successive versions featured a 5-inch tube.

About the same time a new home device — television — was capturing imaginations. Using tubes and high voltages, these TV sets required frequent repair, so many TV repair shops sprang up. **Figure 2.5** is an example of the typical oscilloscope found in many TV shops, a Dumont 274. RCA, which at the time was a TV manufacturer, a communications company and an educational institute, jumped in with its student-oriented scope in **Figure 2.6**. Now hams had three sources of oscilloscopes for the shack and workbench — kits such as the Heath and Eico, moderately priced commercial units such as Dumont and RCA, and, of course, home built.

My Heathkit Oscilloscope Clone

By Tim Walker, W1GIG

In the early 1960s, when I had a young family and was struggling to finish my new house in Utica, New York, I needed a scope to service my hi-fi gear. I had previously built one from the *ARRL Handbook* that used a small diameter 913 tube for the display, but a 1-inch scope has its limitations. Searching through the surplus stores in the area produced a 3AP1 tube (a 3-inch CRT) and a scope power transformer. Of course I had the current Heath catalog and in it found the plans for a very nice 3-inch scope. Remember, Heath used to include the circuit diagram for many products in their catalogs. Using mostly parts from my junk box I put the scope together and used it happily.

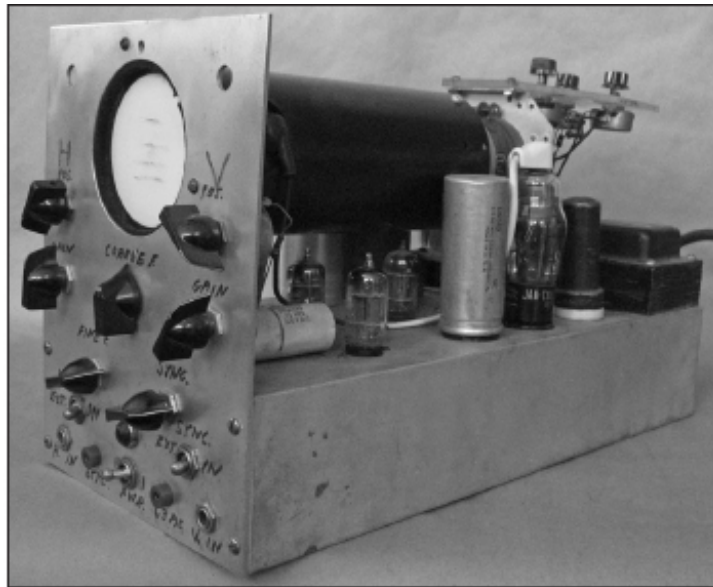

Figure 2.A — Tim Walker, W1GIG, built this oscilloscope as a clone of the Heath scope over 50 years ago. Notice the graticule (screen divisions) consists of markings made with a grease pencil!

A couple of years later, after being transferred to New York City, I found that my new office was in the middle of Radio Row, at the time the surplus electronics center of the universe. You can bet that I spent many a lunch hour checking out all the stores. One day I came upon a 3ACP1 smiling at me from the window of one of my favorite stores. The flat face of the tube promised me a much better scope. For about \$5, I got the tube, the mu metal shield and the special 14-pin socket. Now how to use it?

I found that the Heath design had been updated to use the 3BP1 and miniature tubes. It was now called the IO-21. The only problem was that the 3ACP1 had an accelerating anode that requires 4000 V above the cathode, so I rebuilt the high voltage power supply for my new 3ACP1.

I have been using this scope for about 50 years now. As you can see from the photographs it looks tired, the parts are old and look large as compared to today's parts — but it still works and works well!

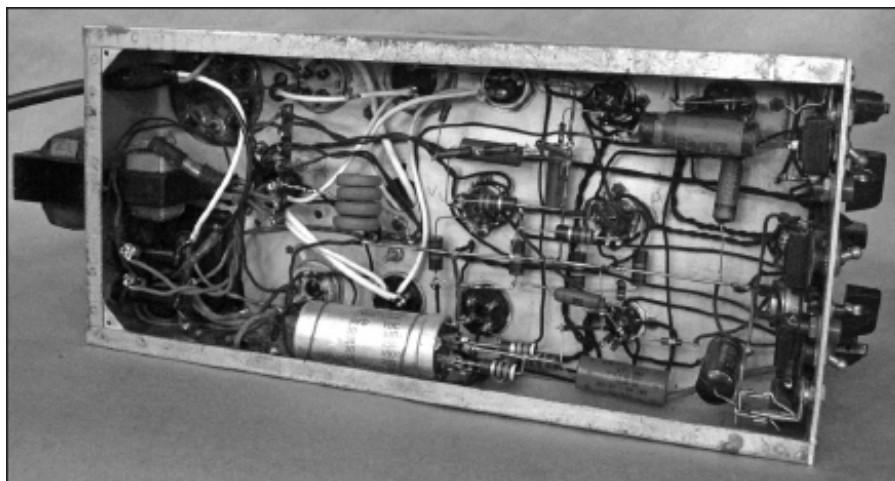

Figure 2.B — The inside of W1GIG's scope. This is the wiring technique typical of a ham 50 years ago.

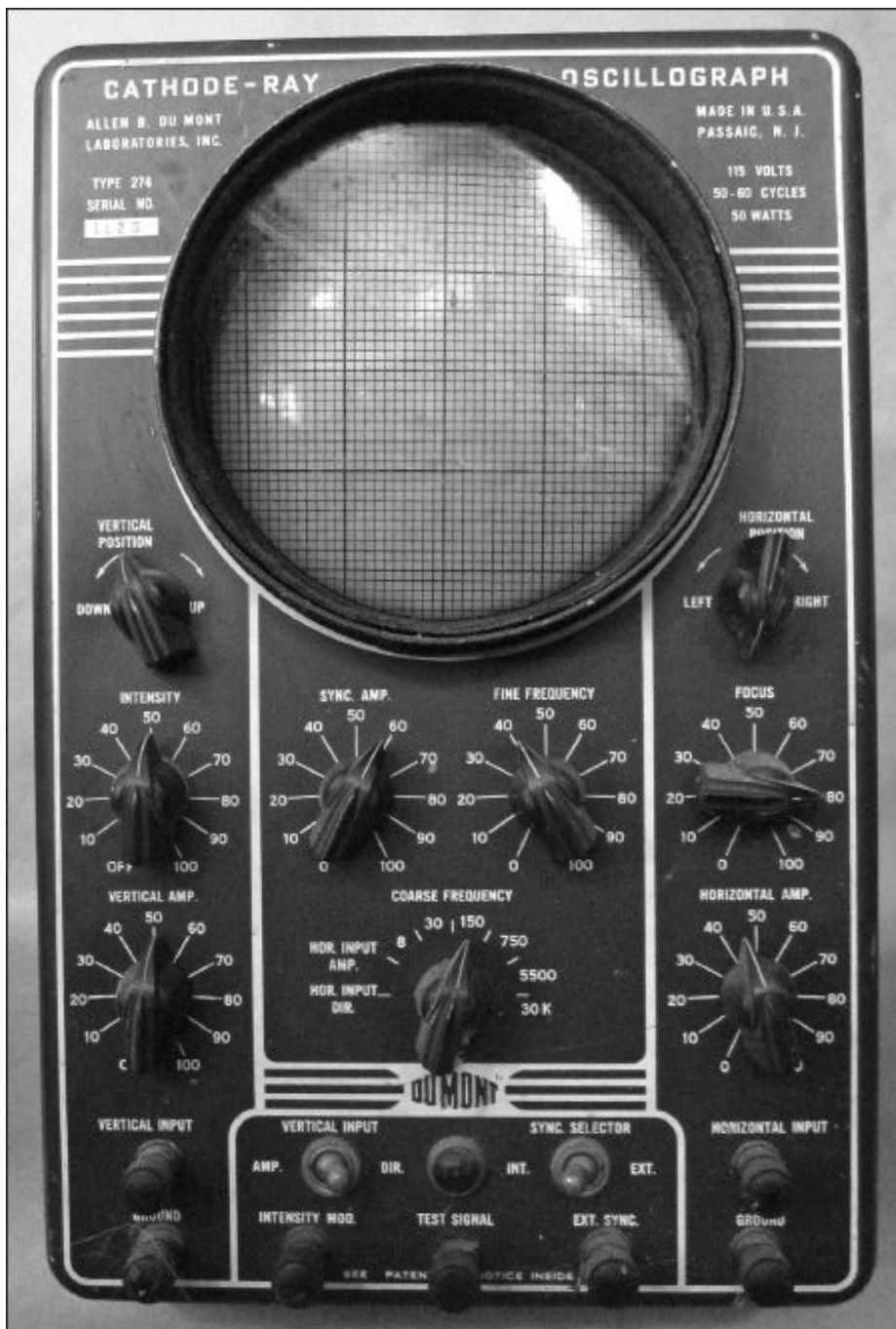

Figure 2.5 — Dumont Corporation was a leader in TV manufacturing, and entered the oscilloscope market with a unit that was widely used in TV repair shops. [Photo courtesy of Tim Walker, W1GIG]



Figure 2.6 — RCA was also heavily in the TV business and the education field. Their scope was specifically set up to be easy to use by students. [Photo courtesy of Seth Goltzer, W1SHG and Don Hudson, KA1TZR]

Advances in Industry

In the 1960s, 70s and 80s, commercial electronics labs outgrew the Dumonts in favor of precision laboratory scopes. Tektronix was perhaps the most common name seen in commercial development and military contractor labs, followed by Hewlett-Packard. They had several things in common:

- They were expensive — several thousand dollars to more than \$10,000.
- They were heavy — often they were mounted on a cart
- They required a great deal of maintenance, including tube replacement and calibration.
- They often required air conditioned rooms because they radiated a lot of heat and did not fare well in high humidity.

Typical of this generation is the approximately 70-pound Tektronix 535 shown in **Figure 2.7**. At the lower left is an exchangeable front end that allowed the scope to be used for various purposes, but this room-warmer dissipated around a half-kilowatt! As succeeding generations of scopes were replaced with newer and more capable units, these vacuum tube based units often were sold for a few hundred dollars — which meant that they ended their lives in a ham workshop.

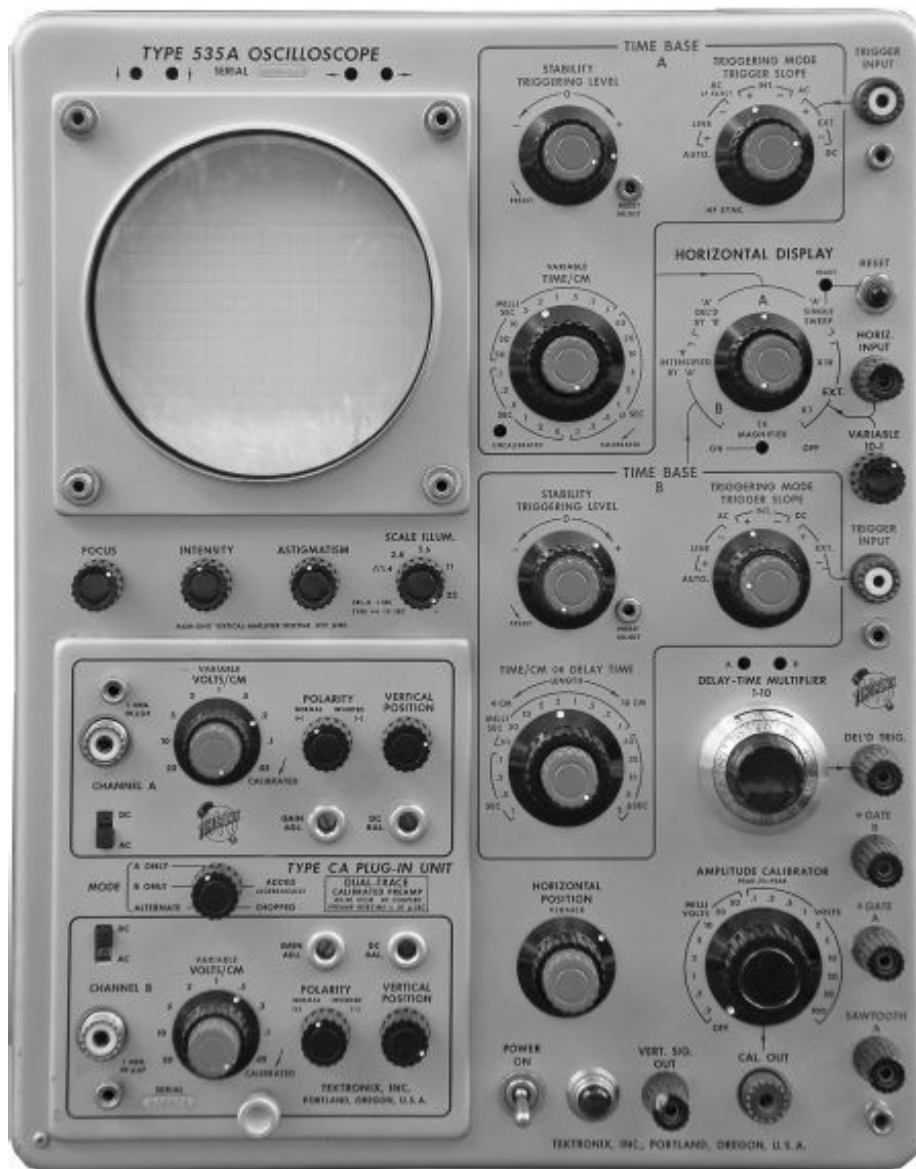

Figure 2.7 — For a number of years Tektronix was the primary precision oscilloscope company. This model 535 is only one of the many 500-series scopes that would be found in almost any industrial lab. [Photo courtesy of w140.com/ tec wiki]

Of course, as you might expect, the appearance of the transistor and integrated circuit changed things completely. By comparison the solid-state Tektronix 2215A in **Figure 2.8** weighs around 15 pounds, dissipates 40 W and is typical of this later generation of scopes. As happened with the preceding tube-based scopes, newer and newer units replaced the older ones in the industrial labs. Once again, for a few hundred dollars (and often less) the newer solid-state units replaced the older ones in ham workshops.



Figure 2.8 — The vacuum tube lab scopes were replaced by solid state lab scopes weighing perhaps one-fifth of the weight of their predecessors and requiring a tenth of the ac power. [Photo courtesy of Rich Roznoy, K10F]



Figure 2.9 — In addition to Tektronix, other manufacturers sold lower cost solid state scopes with excellent performance specifications. [Photo courtesy of Tim Walker, W1GIG]



Figure 2.10 — Heath also upgraded from tubes to solid state and higher frequency performance. The input section of these kits looked more like a receiver front end than a piece of test equipment. [Photo courtesy of Seth Goltzer, W1SHG and Don Hudson, KA1TZR]

Companies such as BK Precision (Figure 2.9) jumped in to supply repair shops and more well-funded hams. And of course Heath remained a ham workshop favorite with models such as the 4554 (Figure 2.10) Suddenly hams no longer need to shop for obsolete tube-based scopes!

Today's Choices

Today — do you want a new scope for \$150-\$350? Take a look at Figure 2.11. This instrument is dual channel, includes self-calibration, is solid state, includes every mode that the older scopes had and more. But where is the display screen?



Figure 2.11 — Digital signal processing changed the entire look of oscilloscopes. Although scopes including a CRT or flat screen display continue to be available, lower cost alternatives consist of processors connecting to a PC or laptop.

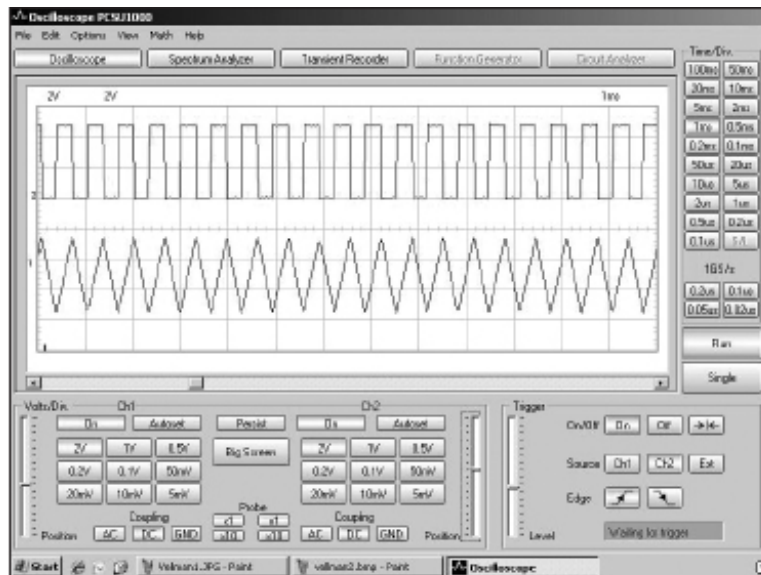

Figure 2.12 — The lack of a display in the newer generation of scopes did not really make much of a change. The display and the controls now showed up on the PC, controllable by both mouse and keyboard.

The answer is, it is attached to your desktop PC or laptop and uses the computer's monitor. Only the analog front end, A/D converters and some digital control circuits are in the small box shown (8 inches high, 2 inches wide and 7 inches deep). The input is converted to a digital signal and sent to the computer, generally through a USB port. There is no power supply or connection — it is powered by the USB port. Processing for display is done by software in the computer.

If you feel that you are missing the familiar oscilloscope front panel — well, just look at the synthesized panel of a PC-based scope in **Figure 2.12**. Notice the bar at the top. Not only is this dual-channel scope, but most units like this also function as a spectrum analyzer and storage scope or transient recorder.

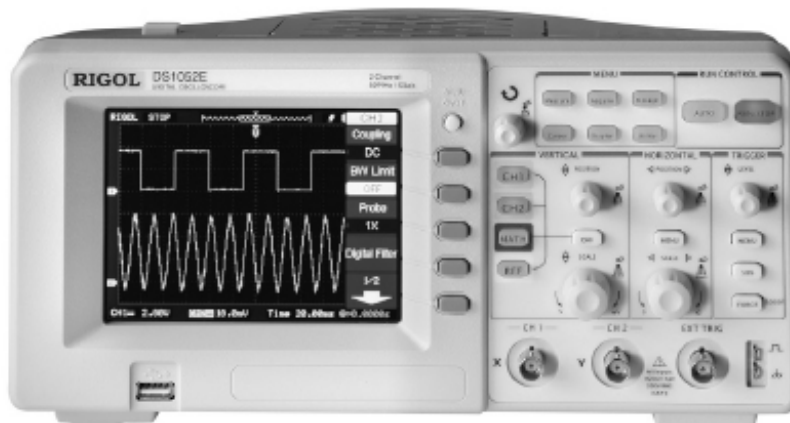

Figure 2.13 — Today's digital storage oscilloscopes have a color LCD display, and are much smaller, lighter and less expensive than their predecessors.

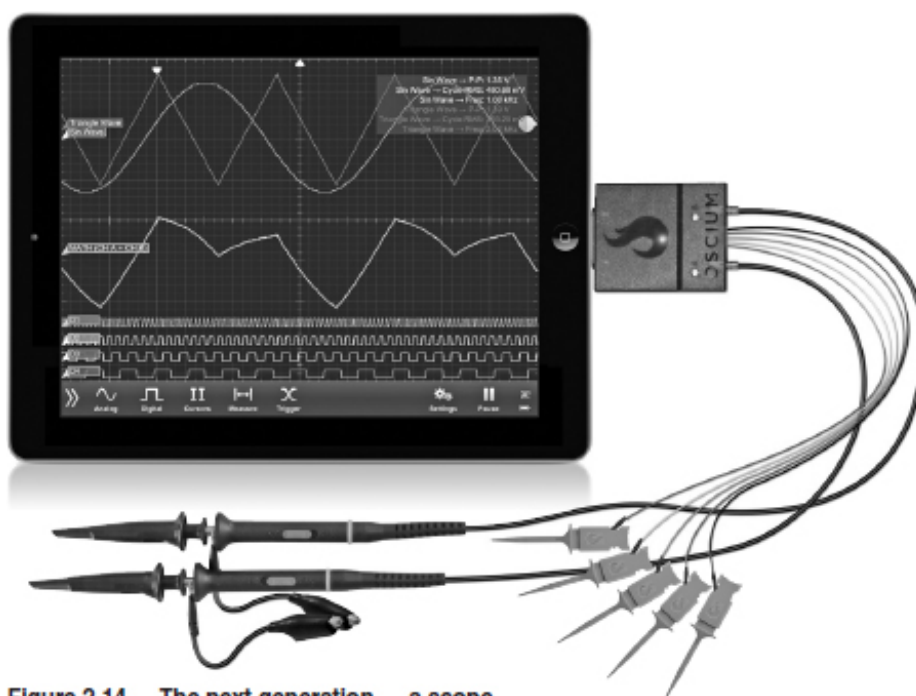

Figure 2.14 — The next generation — a scope in your pocket. Plug it into an iPad or iPhone and you are ready to test. [Photo courtesy of Oscium, Dechnia, LLC]

If you still like the idea of a self-contained oscilloscope with built-in display screen, low-cost digital storage oscilloscopes such as the one shown in **Figure 2.13** are available from a number of manufacturers. Costing as little as \$300 and weighing about 5 pounds, they have a color LCD display.

Not enough for you? How about the Oscium scope in **Figure 2.14**. Shirt-pocket size, it plugs into a tablet such as an iPad, and it has all the capability and features of its predecessor larger units.

As we will see in the next chapter, scopes the described here, starting with the post-World War II units until today, all have as a minimum the same four basic sections — whether built in hardware or part hardware-part software.

Chapter 3

Every Scope Has These Elements

Every oscilloscope contains the four *functional* parts shown in **Figure 3.1**. Notice the word *functional*. Early in the history of oscilloscopes there were generally four actual circuit sections, but not today. When microprocessors, fast analog-to-digital (A/D) converters, personal computers and flat panel displays made their appearance, oscilloscopes reflected these new technologies.

Today's scopes are part hardware, part software, sometimes part personal computer (or laptop, netbook, tablet, and so on). Sometimes they are even software alone.

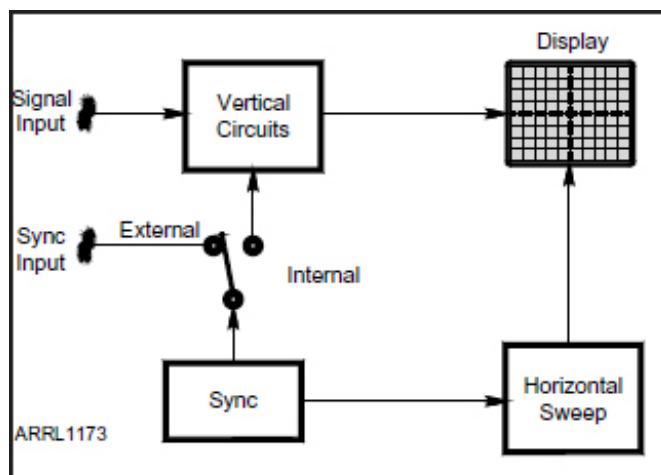

Figure 3.1 — All oscilloscopes, whether built entirely in hardware or part hardware/part software, have these four functional areas.

You might also notice that a fifth functional area, a power supply, is not included in the figure. The reason is simple — many modern scopes do not have an internal power supply. They use power taken from a USB port or other connection to a computing host.

This chapter briefly describes each of the four functional areas. Later, in Chapter 6, you will find more details on these sections and their capabilities.

Vertical Circuits Handle the Input Signals

Other than the power supply, the *vertical circuit* or *vertical channel* is the only part of an oscilloscope that must be designed, at least in part, as an analog circuit. The object of the vertical circuit is to put the waveform on the screen with minimum distortion. It must also be able to limit the voltage of the input signal — perhaps attenuate it, in conjunction with a test probe, or amplify it — so that it falls within the limits of the circuits that follow.

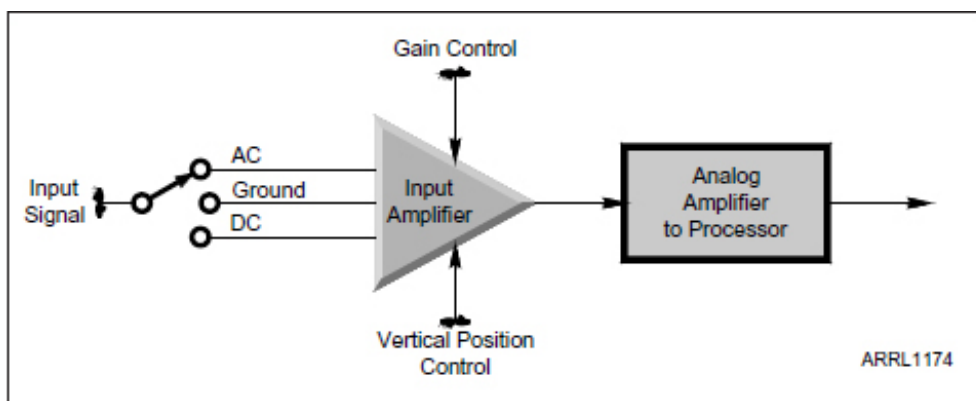

Figure 3.2 — The input stage usually incorporates some sort of overvoltage protection. The gain and position controls shown may be augmented by processing in digital scopes. The ground position disconnects the input signal and shorts the amplifier input signal to ground.

Figure 3.2 is a simplified block diagram of an input stage. The first switch allows you to select DC and see the absolute level of a signal. The second position is AC — in general a capacitor blocks the dc voltage and only the ac component is seen. Quite often there is a third selection — GROUND. This is used to position the trace, without a signal, anywhere you wish on the screen.

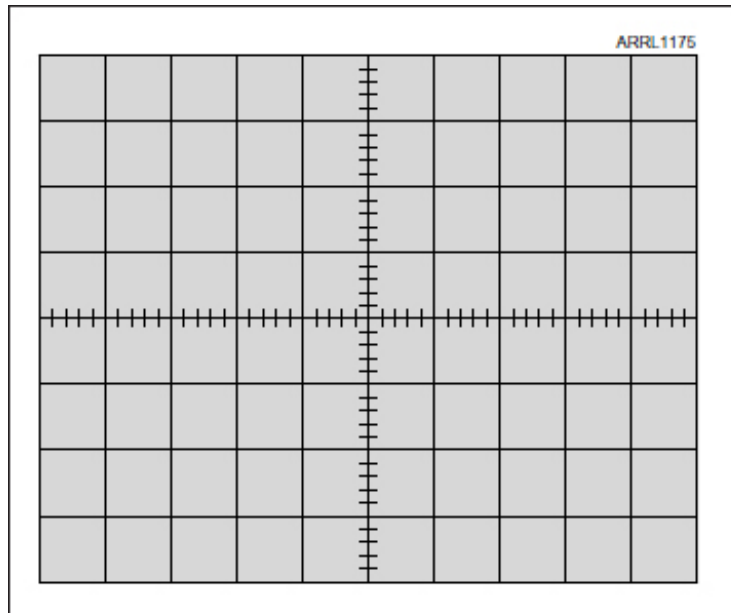

Figure 3.3 — The graticule is usually calibrated in centimeters for the major divisions and tenths, fifths or quarters of a centimeter for the minor divisions.

Most scopes have an overlay on the screen, called a *graticule*. Analog scopes typically have the graticule as a physical plastic overlay, while modern digital scopes often use an electronic pattern on the screen. As seen in **Figure 3.3**, it is customary to have the graticule calibrated in centimeters, and as a result the input voltage scale is usually stated in *volts per centimeter (V/cm)*. The horizontal time scale is usually described in seconds, milliseconds, microseconds or other time units per centimeter — such as *3 ms/cm* or 3 milliseconds per centimeter.

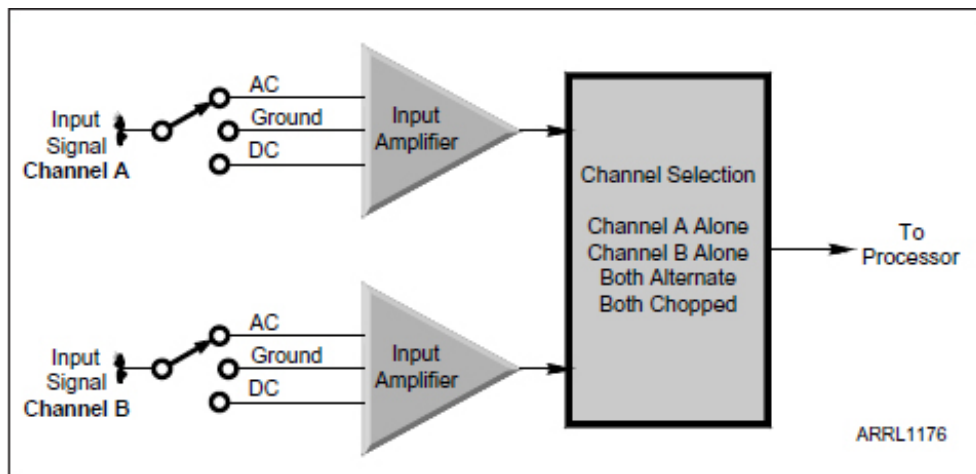

Figure 3.4 — An expanded block diagram for analog scopes shows two input channels, each preceded by a selection switch and followed by channel selection controls.

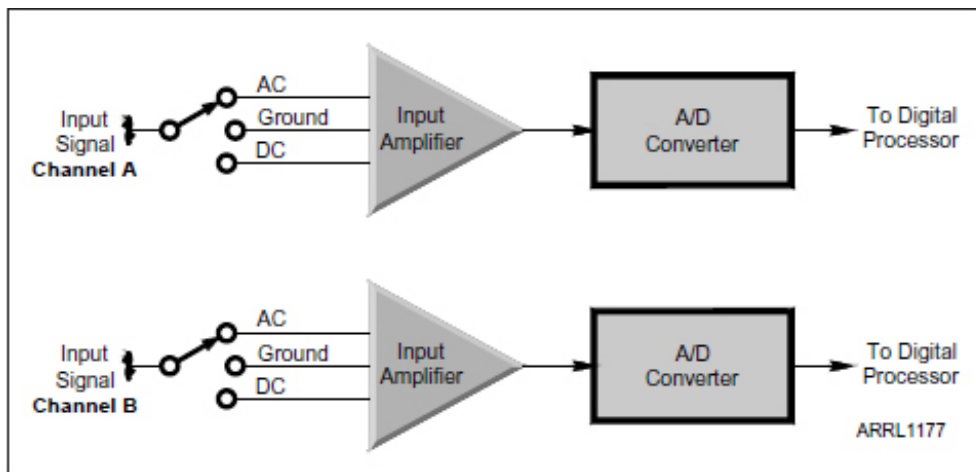

Figure 3.5 — A digital scope follows the input stage(s) with an analog-to-digital (A/D) converter. Some less expensive scopes share a single A/D converter between the two channels.

An expanded block diagram is shown in **Figure 3.4**, where two input channels (*dual channels*) are shown. Each input channel is preceded by the selection switch just described and followed by circuits that allow selection of:

- a single input channel
- both input channels simultaneously and alternately, or
- both input channels simultaneously and combined (added together or one subtracted from the other).

An additional choice is *chopped*, where both channels are shown simultaneously but processed so you see both but they are alternately sampled, one after the other.

In an analog scope the output of these stages goes to additional amplifier. In many modern scopes, the first stage output goes to A/D converters (**Figure 3.5**) and the channel selection is done in processing past the A/D converters.

The Horizontal Section Sweeps the Trace Across the Screen

Since an oscilloscope usually shows a quantity — say a voltage — as it varies with time, the horizontal axis represents time. The start of time, or what is generally called $t = 0$, is on the left side of the screen. How fast the trace moves across the screen is the *sweep rate*. This can vary from seconds per centimeter (s/cm) to nanoseconds per centimeter (ns/cm). Lower sweep rates are used for voltages that vary slowly.

As an example, suppose you wanted to take a close look at a 60 Hz sine wave. The time for one such wave, or the *period*, is calculated as $1/\text{frequency}$ or $1/60$ of a second — or approximately 16.66 ms (milliseconds). Most oscilloscopes have a graticule calibrated as 10 centimeters (cm) wide. A sweep rate of 2 ms/cm would have the trace cross the entire 10 cm wide screen in 20 ms, so a bit more than one cycle (16.66 ms) of the 60 Hz waveform would be seen.

If we doubled the sweep rate to 4 ms/cm the time to cross the screen would be 40 ms, and $40/16.66 =$ approximately 2.4. In other words, 2.4 complete sine waves would be visible.

With a completely analog scope, a voltage would be applied to two horizontal plates in the display cathode ray tube (CRT), with a waveform as shown in **Figure 3.6**. In the figure the voltage (A) initially puts a dot at the left side of the screen, and as the voltage increases the trace moves to the right side of the screen.

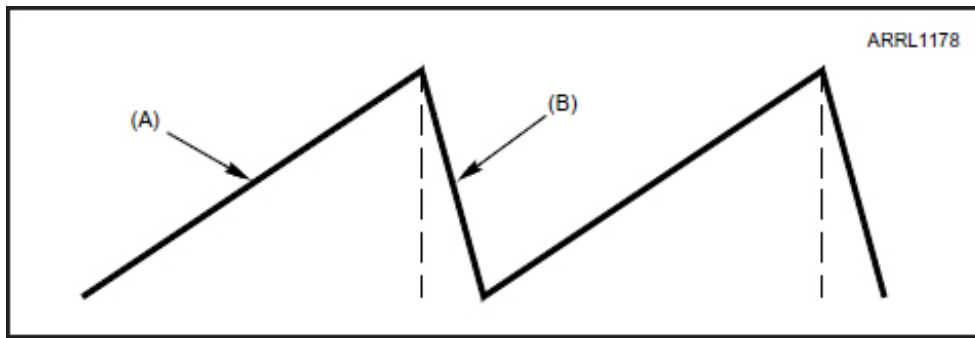

Figure 3.6 — The sweep voltage labeled A sends the beam across the screen from left to right. Waveform section B *retraces* the beam back to the left. During this retrace time the electron beam is cut off. In a digital scope the retrace time is the time to reset the counter and is reduced to close to zero.

Today, of course, most scopes do not use CRTs and the output goes to a digitally-generated display — usually a flat screen LCD of some sort. In this case, the analog voltage of Figure 3.6 would be replaced by a digital count. A count of zero would place the dot at the left edge, and as the count increases the trace would move to the right. Sweep speed would be controlled digitally. You can look at the horizontal position as the count in a digital counter — the faster the input clock to the counter, the faster the trace goes across. In other words, the faster the input clock, smaller the time per cm.

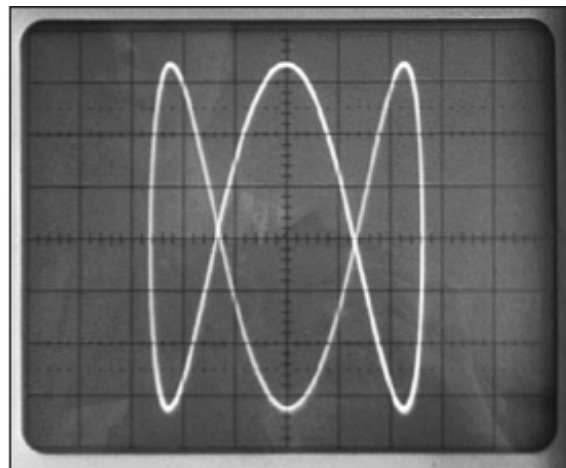

Figure 3.7 — A 3:1 Lissajous pattern. One input goes to the normal vertical input and the second to the horizontal input in place of a sweep voltage.

Some oscilloscopes have an additional mode, where the sweep circuit is disabled and one channel, say channel A, is connected as usual to the vertical axis and the second channel, channel B, is connected to the horizontal axis. This permits an on-screen plot of one signal against another. Where the frequencies of two signals are related, say one is a sine wave at 1000 Hz and the other a sine wave at 3000 Hz, the pattern will tell you the frequency relationship by counting the lobes on the screen. This display is called a *Lissajous pattern* and the one shown in **Figure 3.7** has a 3:1 relationship.

At this point you can see that a oscilloscope today could be totally analog, with precision analog circuits and a CRT display. Or, a scope can be totally digital, converting the analog input immediately to digital and processing it and the sweep in digital circuitry. Many scopes are in fact a combination of the two.

The Sync Circuit Triggers the Sweep

All scopes, digital or analog, must have a way to make the displayed waveform seem to stand still on the screen. This is the function of the *synchronization* or *sync circuits*. If we let the sweep circuit run free — there is no relationship to the input waveform — the waveform in **Figure 3.8** is the result. Each successive input waveform starts at a different point, and after a number of input waveforms the entire screen fills. However, if we *trigger* the sweep so that each sweep starts as the input waveform equals a set voltage — as in **Figure 3.9** — then a single waveform is seen. Actually it is many waveforms, but perfectly superimposed on each other. Figure 3.9 shows two trigger points. For trigger point A, +1 V is selected with a positive slope. Point B shows

where the trigger point would be if +1 V is selected with a negative slope.

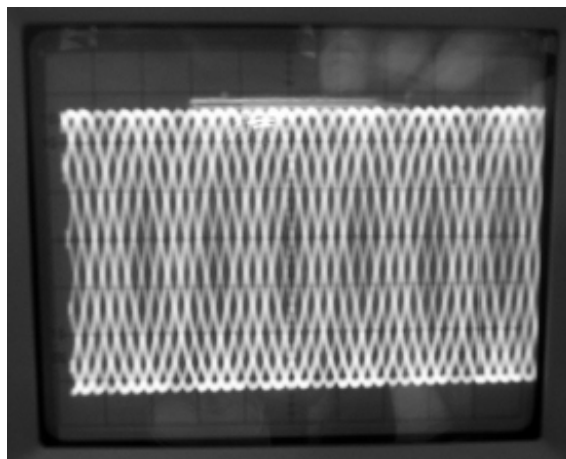

Figure 3.8 — If we let the sweep circuit run free — there is no relationship between the sweep voltage waveform and the input signal — this could be the result.

Individual scopes have sets of trigger selection features. Generally there is a voltage level selection that determines where on the input waveform the sweep should start. Often there is a slope selection — whether the selected voltage trigger point should be on a rising waveform or a falling waveform. Additional choices include picking either channel A or channel B for sync trigger, ac coupling or dc coupling to the sync circuit and often a *line* or 60 Hz sync input on older scopes.

Should you decide to buy an older scope, don't be surprised if the sync selection also has positions labeled HORIZONTAL and VERTICAL. These were positions used to service analog TV sets before the switch over to digital TV.

While the sweep usually is triggered — starts — immediately as the selected trigger point occurs, more complex scopes (often more expensive scopes) often have a delay feature. The trigger selection picks the start point, but the actual sweep does not start until a later selected time. This feature is known as the *sweep delay*. In Chapter 6 we will discuss one of these delay features that has some interesting ham radio applications.

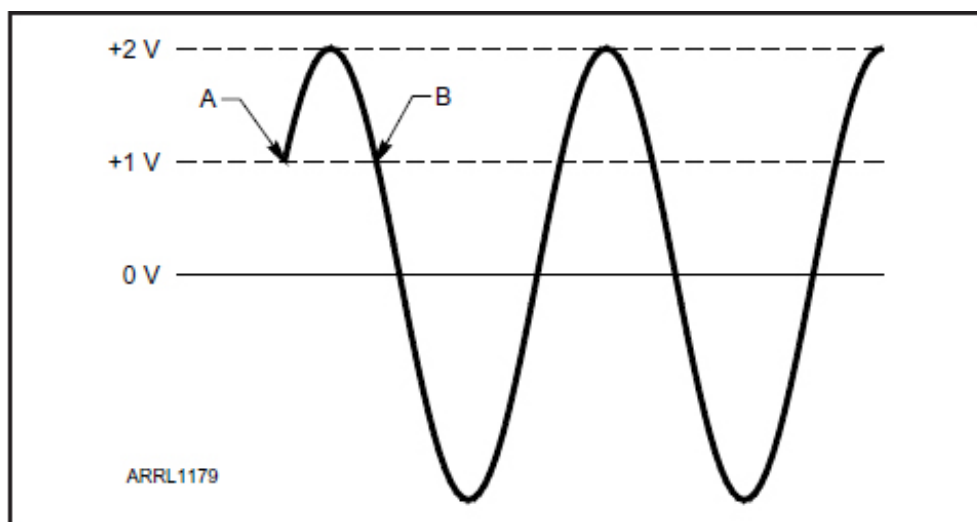

Figure 3.9 — Using a selected trigger point, each repetition of the input coincides so a clean, synchronized picture results.

Display Types

Currently there are three popular oscilloscope displays: a cathode ray tube (CRT), a flat panel LCD or TFT display such as used with most personal computers, and ... none. The first two are physical, and integrated into the oscilloscope cabinet or enclosure. The last represents modern scopes that consist of a processing front end plugged into a PC, tablet or even a smartphone.

Classic Cathode Ray Tube

The cathode ray tube, or CRT, was the earliest oscilloscope display component. For a screen size of five or so inches across, the scope designer had to use a package that was fairly deep (12 inches or more) and allowed a great deal of heat to be radiated. Most important of all, the CRT required a power supply of perhaps several thousand volts.

The back end of a CRT resembles a standard vacuum tube (**Figure 3.10**) with a filament to heat the cathode. Electrons radiating from the cathode pass through a grid and are then pulled forward toward the screen by a combination of a positive voltage on a hollow anode and a high positive voltage applied to conductive layers on the sides toward the front of the tube.

The spot where the electron stream hits the phosphor-coated front screen illuminated a dot. The position of the dot is controlled by four deflection plates. **Figure 3.11** illustrates the plates, showing an illuminated spot toward the upper left corner. The electron stream is pulled up by having the voltage on plate A positive with respect to plate B. In the same way the spot is on the left because the voltage on plate C is positive with respect to plate D. If there were no voltage difference between A and B, and no difference between C and D, the spot would be in the middle of the screen.

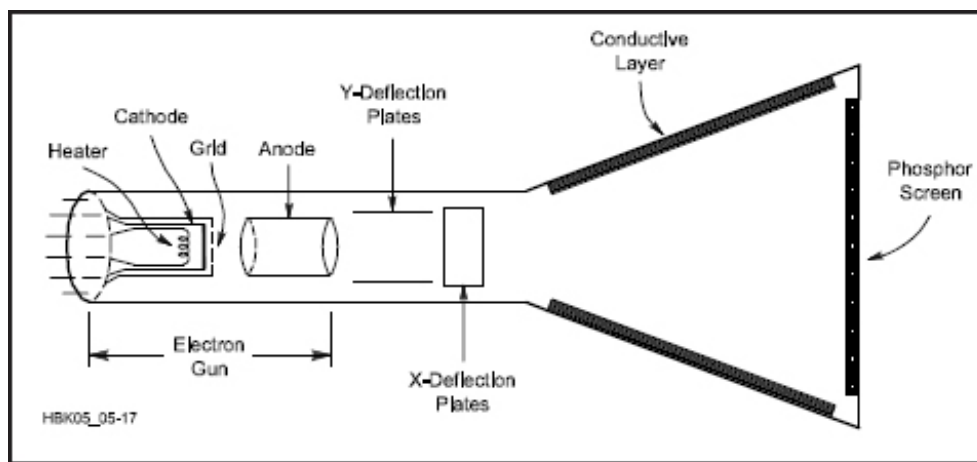

Figure 3.10 — A CRT is basically a vacuum tube with a filament to heat the cathode. Electrons travel from the cathode through a grid toward phosphor coating on the front screen.

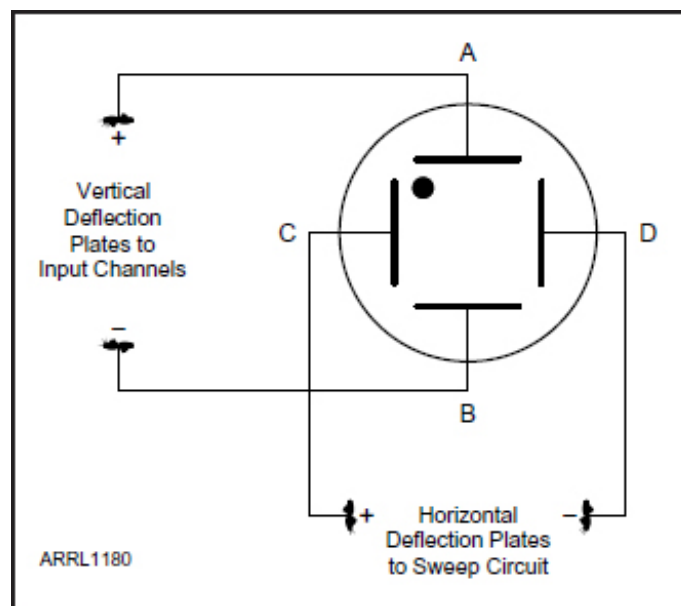

Figure 3.11 — The bias voltages shown here on the plates pull the electron stream toward the upper left corner of the screen.

Brightness is controlled by the grid, just as the grid in an ordinary vacuum tube controls the flow of electrons toward the plate. The vertical channel is connected to plates A and B, and the sweep circuits connect to plates C and D.

Self-Contained Flat Panel Display

Unlike the CRT, newer scopes incorporating flat panel displays do not require a deep enclosure, do not need high voltage and do not generate a great deal of heat. A good scope display, like a good TV screen, does require a device with reasonable resolution, a very flat face and a long life.

Typical of such a display is the one used in the Rigol DS1052e, pictured in **Figure 3.12**. It has a 5.6-inch diagonal color LCD (liquid-crystal display) screen using TFT (thin film transistor) technology. Very similar displays are now being offered on the front panel of Amateur Radio transceivers from several manufacturers.

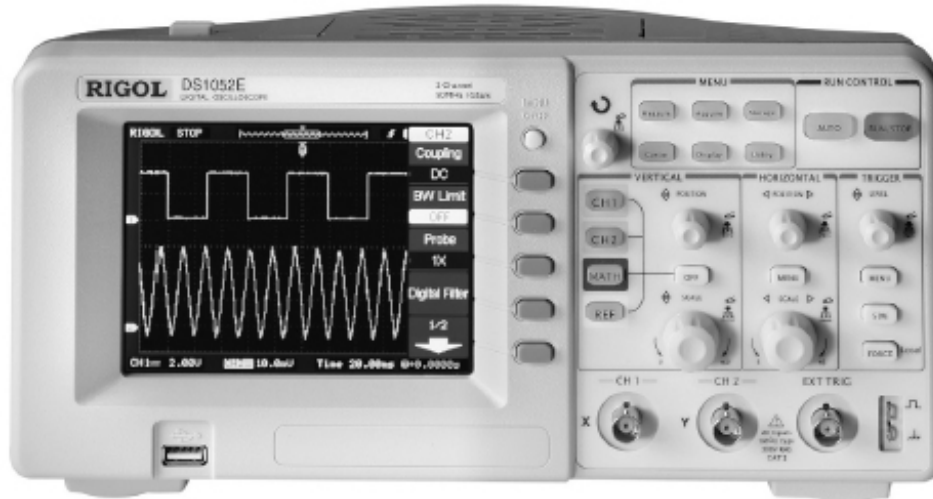

Figure 3.12 — Typical of modern color flat panel displays is the one built onto the Rigol DS1052e.

The scope size is driven by the front panel, containing the display and the manual controls (knobs and switches). The depth, approximately 5 inches, is all that is needed to contain the circuitry of a very capable scope.

No Display, No Power Supply

Imagine taking the scope in Figure 3.12, eliminating the front panel and just packaging the internal circuit board — perhaps in a package 1-1/2 inches wide by a few inches high and 5 inches or so deep. The front panel holds jacks for two probes and the rear panel a connector for a USB cable to a personal computer. The USB port supplies power to the scope and the signal lines in the USB cable feed the two channel inputs, digitized, to the personal computer. Figure 1.4 in Chapter 1 shows one such scope.

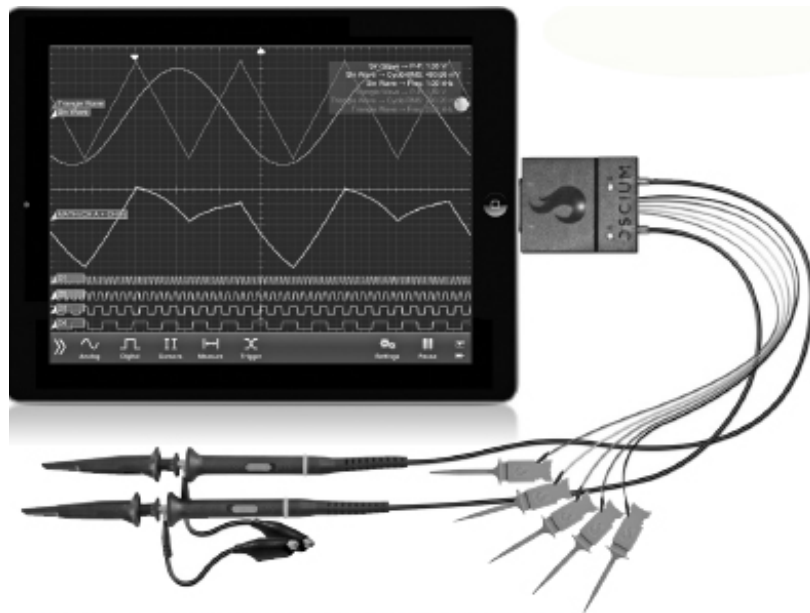

Figure 3.13 — The tiny Oscium IMSO-204 has only a 5 MHz bandwidth and uses an Apple iPad or iPhone for control and display. It is designed for use where a larger standalone oscilloscope or one that plugs into a personal computer or laptop is too big to be accommodated. Want to carry a scope to the top of a tower?

Figure 3.13 shows an even smaller — although less capable — scope, the Oscium iMSO-204. It plugs directly into an iPad, iPhone or other Apple device. Similar models, roughly $2.5 \times 3.25 \times 0.75$ inches, are available with USB connections.

Some Scopes Can Store Your Waveform

Today's technology has brought us some interesting capabilities, some directly and some indirectly. With an older scope, if you had a waveform that you wanted to look at in detail, and it occurred only once, you would have to look very quickly. When the image seen through the illuminated phosphor on the screen faded, so did your capability to look.

Some older analog scopes had *storage* capability. The CRT had a special phosphor and voltage circuitry that permitted a long persistence on the screen. Generally, *storage scopes* commanded a much higher price than conventional scopes.

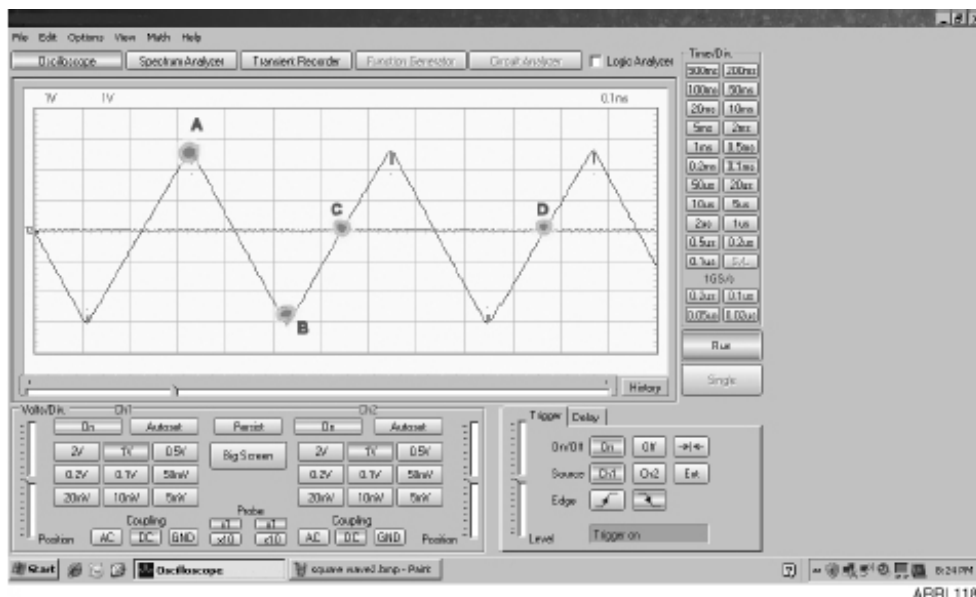

Figure 3.14 — The digital processor can detect points A, B, C and D and automatically calculate maximums, minimums, RMS, average, period and other waveform parameters.

With today's scopes that digitize the incoming waveforms, storage capability is the normal mode. Each increment of the waveform is stored as a digital number. During each new sweep across the screen these

numbers are replaced by the new incoming waveform voltages — a new set of numbers. Want storage of a waveform? Just inhibit the new set of numbers. Get one sweep, hold the numbers and look as long as you want!

Since each point on the incoming waveform is held as a digital number, you can get indirect benefits — math functions are almost free, since they are just digital processing. As an example, look at the triangular waveshape in **Figure 3.14**. Want to know the peak-to-peak voltage? Find the highest number (point A in the drawing) and the lowest number (point B in the drawing), take the two digital numbers, subtract, and you have the peak-to-peak value.

Want the period? Pick a point on the waveform (here point C, which is a zero crossing with a positive slope) and a corresponding point D. Measure the time between the two and you have the period. Calculate average? Calculate RMS? The scope has the data in digital form; the calculations are fairly simple since you are using a digital processor. Of course you don't pick the points and do the math; the software does it for you.

Where waveform storage used to be an expensive option, it is now the norm with a number of indirect features — calculations and numerical measurements — readily available.

Chapter 4

Probes and Accessories

Suppose it is a beautiful day outside. You look through the window — the sun is shining, the grass is green, the air is clear and you can see some small birds pecking around on the grass. Now change things a bit. Leave the outside as it was, but make the window dirty. It has been splashed by mud, coated by greasy fumes and sticky dust, and it casts an uneven gray over the scene. Now you look out and suddenly the beautiful day looks dreary and unappealing. What you see is not what is there.

The same situation occurs with an oscilloscope. The probe or probes connect the signal you want to see with the oscilloscope input circuits. The probe can have a major effect on what you see, yet many people take it for granted.

Do You Really Need a Probe?

In an ideal world, you could find a probe that you could ignore. Such a probe would be easy to use — just connect it to your circuit. It would not distort the signal in any way, it would look to the circuit as though nothing were connected (does not *load down* the circuit), and random noise pulses from other circuit elements would be rejected if there were any!

Of course this is not an ideal world, and a perfect probe does not exist. To see what does exist, first we have to remember that when you are looking at a signal at one frequency it has *components* — we will see shortly what is meant by *components* — at many frequencies. Remember: if you are looking at a 7 MHz square or sawtooth waveform, this is the same 7 MHz as the RF coming out of your transmitter when you are operating on 40 meters. You would not expect to run a 40 meter signal down a single 12 or 18 inch long piece of wire without having some sort of problem. At a minimum you would use a piece of coaxial cable or special shielded wire — and this is where the problem begins.

There are a few very limited cases where a short — say 6 inch long — piece of wire could be used, such as the four logic signal inputs on the Oscium iPad oscilloscope described in Chapter 3. This is a very special case where the signals are limited to relatively low frequencies (that scope has a 5 MHz bandwidth). Actual signal shape is less important and logic signal position is the important item.

What Does a Probe Look Like from the Signal's Point of View?

Let's suppose you have a scope with a 100 MHz bandwidth and the probe consists of a piece of coax, with the center of the coax connected to the signal you wish to see. **Figure 4.1** is a model of a piece of coax.

Notice that it has inductance, resistance, and capacitance — that is, it looks like a network made up of these elements. If you are looking at a 6 meter (50 MHz) signal, the input sine wave to the probe would show up at the output — that is, at the scope input jack. There would be some small losses, but a sine wave in would be a sine wave out. Unfortunately, if you were looking at a square wave, sawtooth, triangular or any other repetitive, non-sinusoidal signal, the output at the scope would not look exactly as the input to the probe.

In order to understand where this difference comes from we have to look at a little math — a technique known as Fourier analysis. In summary, this math principle says that for any repetitive waveform (yes it holds for all waveforms) the waveshape is actually composed of a set of overlapping sine waves. **Figure 4.2** shows how this happens, using a symmetrical square wave for illustration.

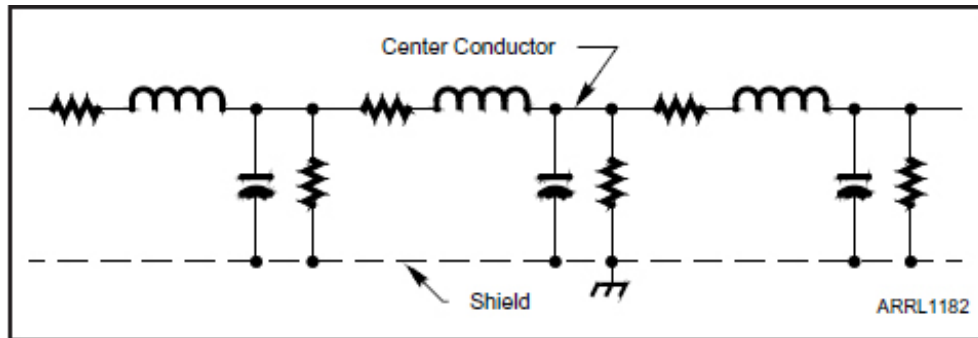

Figure 4.1 — A length of coaxial cable or shielded wire can be looked at as a passive network, which means it has a response that varies with input frequency.

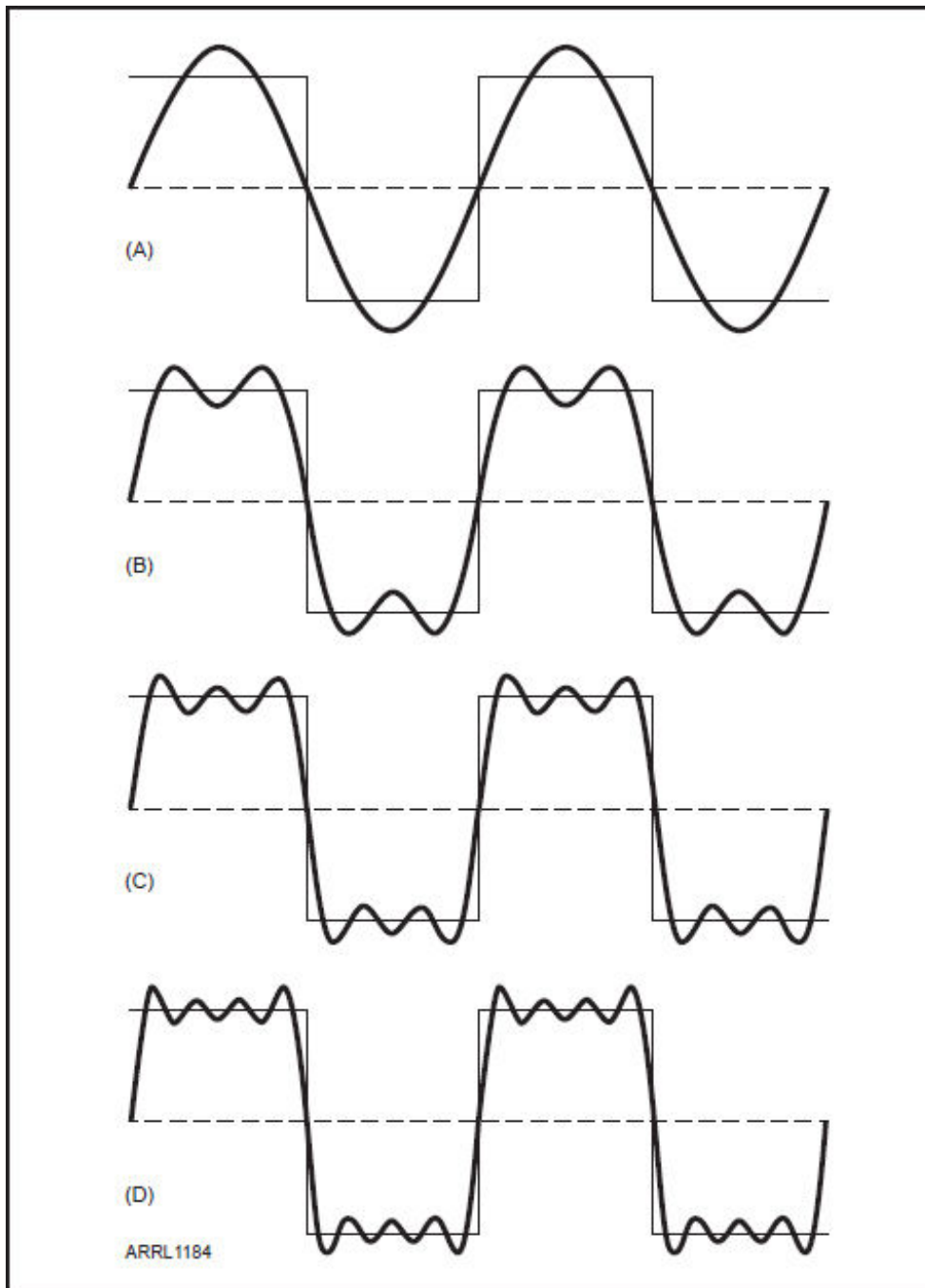

Figure 4.2 — The actual equation for a square wave sums a sine wave at the original frequency at a given amplitude, plus a second sine wave at $\frac{1}{3}$ the original amplitude and 3 times the frequency, plus another sine wave at $\frac{1}{5}$ the original amplitude and 5 times the original frequency, and so on.

In Figure 4.2A a sine wave of the same frequency as the square wave is drawn over the square wave. In Figure 4.2B a sine wave of three times the frequency of the square wave, with a specific amplitude of less than the original sine wave, is added to the first sine wave. You can now see how the combination, or sum, starts to look like the square wave. In Figure 4.2C and Figure 4.2D sine waves of five times and seven times the original frequency, each with a specific calculated amplitude, are added. The result is almost a complete square wave.

To really synthesize a good square wave, more sine waves — each with a different amplitude at odd multiples of the base frequency — would be added until the result was a perfect square wave. Now let's look at a 7 MHz square wave. It would consist of sine waves at 7, 21, 35, 49 (and so on) MHz — sine waves at odd multiples of 7 MHz, each with its own amplitude.

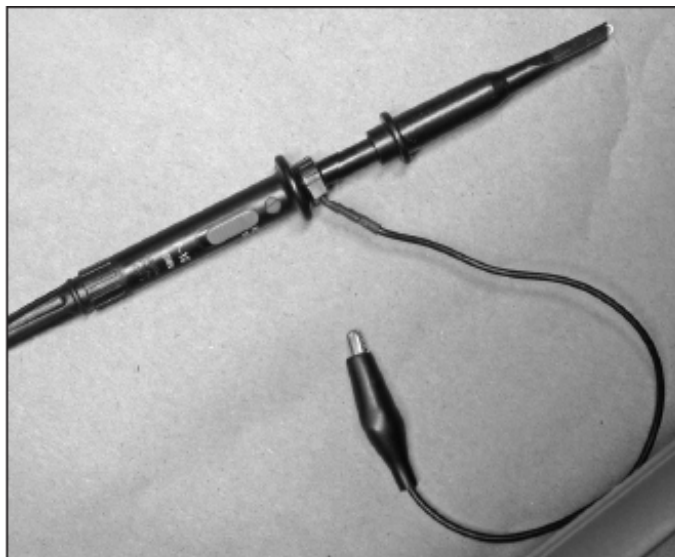

Figure 4.3 — Most low-cost probes that come with an oscilloscope look like this one. The compensation adjustment is the small circle with a screwdriver slot and the slide switch sets $\times 1$ or $\times 10$ attenuation (use $\times 1$ when no attenuation is needed).

Looking back at Figure 4.1, the connecting coax has inductance, capacitance, and even some resistance. Each of these input waves would have a different attenuation and phase shift. So the output resulting from the simultaneous input sine waves at 7, 21, 35 MHz, and so on would no longer add up to the nice square wave we started with at the input. For this reason an oscilloscope probe gets a bit more involved. **Figure 4.3** shows a standard, inexpensive scope probe. The solution to the problem of unequal probe response to varying frequency is called *compensation*. In the photo notice the screwdriver slot, located just below the ground wire connection. This is the compensation adjustment.

Probe Compensation

Each probe manufacturer includes a compensation network to equalize the probe response to various frequencies. A very minimal network is shown in **Figure 4.4**. R1 and C1 — where C1 is variable — provide the compensation for the combination that consists of the coax or shielded wire and the scope input circuit. The scope input acts as the termination of this combination, with resistor values in the megohm region and capacitance of perhaps 5 to 25 pF.

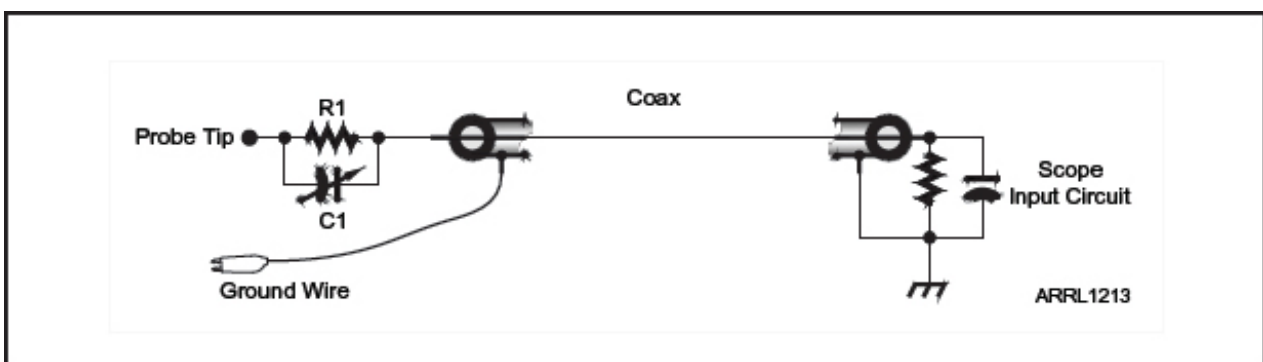

Figure 4.4 — Some compensation networks are as simple as the pair of resistors and capacitors (R1 and C1) shown. There are more complex compensation networks, but all work into the combination of the coax (see Figure 4.1) and the scope input circuit. Some probes can be compensated only in the $\times 10$ position.

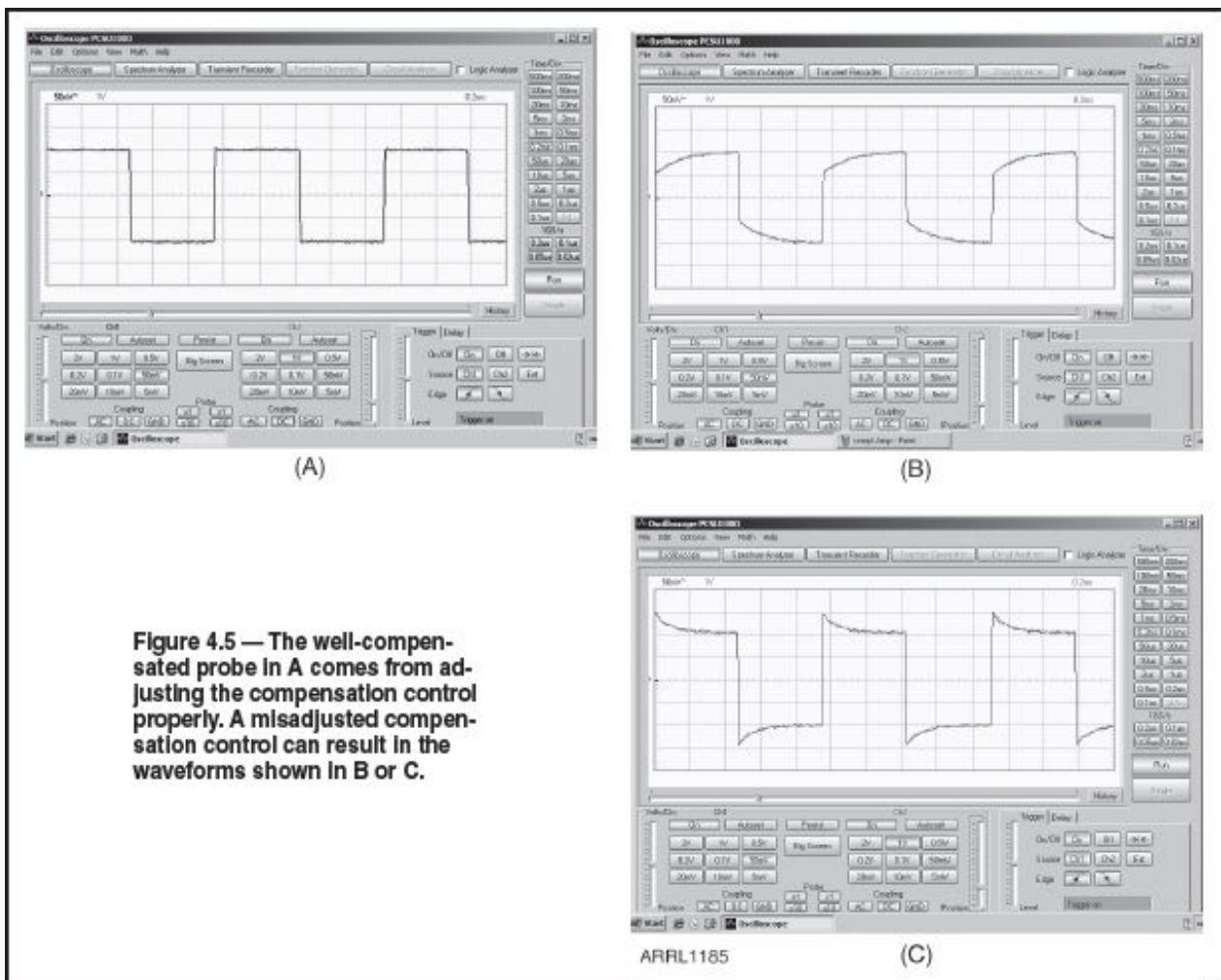

Figure 4.5 — The well-compensated probe in A comes from adjusting the compensation control properly. A misadjusted compensation control can result in the waveforms shown in B or C.

A second resistor and perhaps other components would be added to the probe for the $\times 10$ attenuation selection. This is usually controlled by a slide switch such as the one just below the compensation adjustment in Figure 4.3. This type of probe is generally considered a *voltage probe* since it is used to examine voltage waveforms. The compensation network shown is very minimal; some voltage probes have much more complicated compensation schemes.

The result of connecting a probe to a good-quality square wave is shown in **Figure 4.5**. Well-adjusted compensation is shown in Figure 4.5A, and misadjusted compensation in Figure 4.5B and 4.5C. These figures were obtained by simply rotating the compensation control and capturing the resulting scope trace.

Probe Types and Capabilities

Probes come in two general varieties — active and passive. Most people are familiar with passive probes, such as those discussed in the preceding paragraphs. They have the advantage of generally being inexpensive and the connector, most commonly a BNC, fits many if not most oscilloscopes.

Passive Probes

Passive probes are widely used. For the most part they are generally interchangeable and relatively inexpensive. They do come in several different types. All probes have ratings for voltage maximum and frequency response. Often the frequency response (usually called *bandwidth*) is marked directly on the probe. This may vary from 10 MHz to typically 100 MHz.

The ground wire is part of the measuring circuit, so at frequencies where the inductance of a 6-inch piece of wire could be significant — say 5, 10, or 20 MHz and up — it is possible that that this inductance will cause *ringing* or small damped oscillations on the waveform.

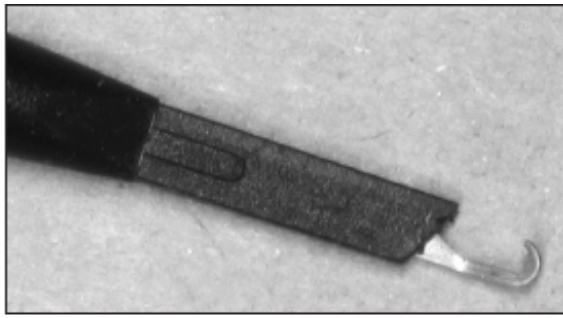

Figure 4.6 — Typical probes have some sort of hook or grab mechanism to fasten onto a circuit lead or test point.

There are two general types of probe tips. A hook end is shown in **Figure 4.6**. By sliding back the ring (just behind the ground wire connection), the hook is exposed. Releasing the ring allows the hook to retract, trapping a wire or test point between the hook and the plastic body. Other designs use opposing wire hooks in a scissors configuration, but they are generally more fragile.

The other type of probe end is usually inside the hook sleeve. This plastic sleeve slides forward and off or unscrews, exposing a pointed probe end (**Figure 4.7**). Generally the only controls on these passive probes are the compensation adjustment and the $\times 1$ or $\times 10$ attenuation selection.



Figure 4.7 — When grabbing a component lead to be examined is not possible a pointed end is available to actually “probe” the circuit point.

Active Probes

Active probes are used where very low loading on the circuit is necessary. Quite often they have a field effect transistor (FET) connected to the probe tip, which means the tip has a very high resistance and low capacitance. They are, of course, more expensive and usually mate only with specific oscilloscopes for which they were designed. Active probes typically have an additional advantage of including automatic calibration. Since an amplifier is located in the tip, quite often this sort of probe has an extended bandwidth of several hundred megahertz.

High Voltage Probes

High voltage probes are used when the normal voltage limits for a passive probe are too low for the circuit under observation. Most passive probes used to be rated at 400 to 500 V (think vacuum tube transmitters), but today it is not uncommon to see a probe rated at only 200 V or even lower, matched to solid state circuits. The key feature of a high voltage probe is safety — the probe body is designed to keep your hand removed from the high voltage.

Occasionally the probe connecting cable is made much longer, for the same reason — to keep your hand out of the cabinet or chassis containing the high voltage circuits. Most high voltage probes match a specific manufacturer's oscilloscope model and they generally are not interchangeable.

Current Probes

Current probes are also generally matched to a specific manufacturer's oscilloscope model or models. They come in two types — ac (alternating current) only and dc (direct current). In both cases the bandwidth tends to be limited.

AC-Only Probes

The *ac-only probe* is simply a transformer. In **Figure 4.8** the two sections shown are basically the transformer core, with the fixed primary wound around the upper section. The rectangular slot is where the wire carrying the current is placed. Squeeze the handle and the two sections open in a scissors mechanism. Insert the wire and the transformer now consists of the fixed secondary winding and the wire (primary) of the transformer.

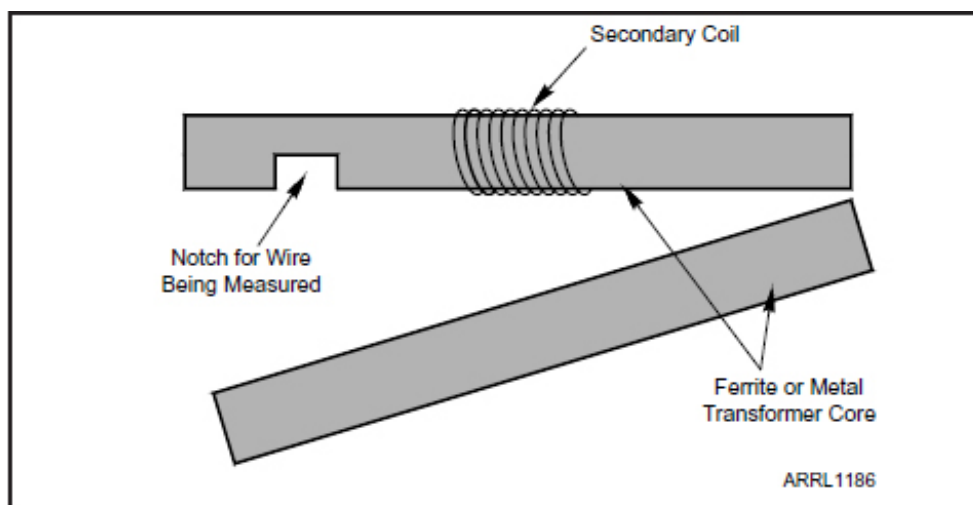

Figure 4.8 — A transformer inside the plastic housing is used for signal pickup in an ac current probe. Once the wire is in place, the lower section closes up next to the upper section, thus completing the magnetic path.

Almost any wire that fits in the probe jaws can be sensed, so the distance of the conductor from the metal core varies. Therefore the amplitude of the current seen on the scope is not very accurate, but within the probe bandwidth limitation the waveform is accurate.

Often an amplifier is included in the probe handle so the connecting cable carries signal information to the scope and power for the amplifier to the probe, along with control signals to the probe amplifier.

DC Probes

A *dc probe* usually uses a *Hall Effect* sensor. This is a solid-state device that detects a magnetic field and produces a (generally) minute output voltage in response to the field. **Figure 4.9** is a generalized curve of a Hall Effect device. As you can see it has a limited range, so the magnetic field from the current being sensed must fall in this range or the sensor will go into saturation, distorting the displayed current waveform.

A block diagram of the dc current sensor is in **Figure 4.10**. The electronics are built into the probe, which resembles the ac-only current probe physically but uses the Hall Effect sensor instead of a transformer winding. Again, the amplitude of the current sensed may not be very accurate, due to varying wire positioning, but the waveshape as seen on the scope is accurate as long as the current probe is being used within its amplitude and frequency limits.

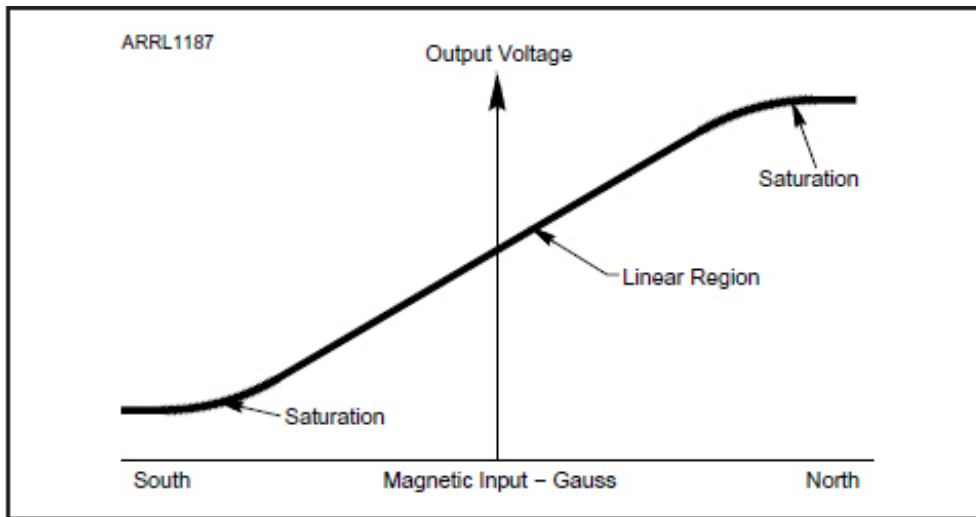

Figure 4.9 — The Hall Effect sensor has a curve that shows the magnetic field strength (horizontal axis) against the output voltage (vertical axis). Notice the saturation areas at the end of the curve. A current that is strong enough to produce a magnetic field in the saturation area will result in a compressed — distorted — waveshape shown on the scope.

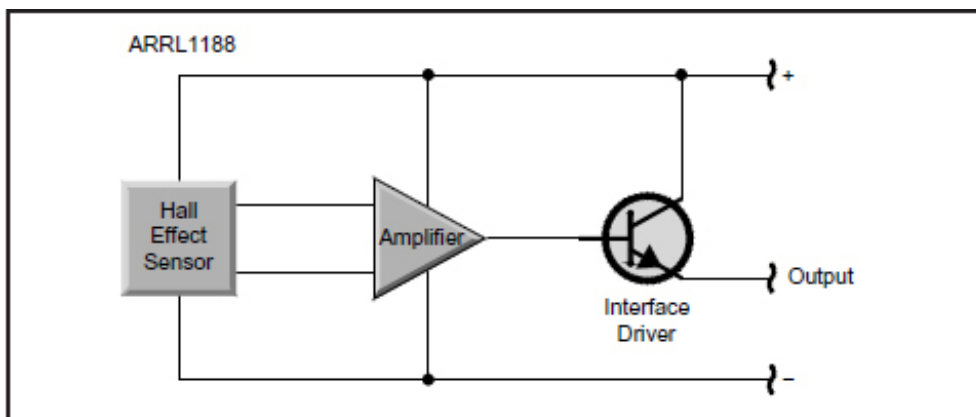

Figure 4.10 — The Hall Effect sensor puts out a tiny voltage, so most commercial units include a preamplifier. The connection from the probe end to the scope must therefore include power wires and sometimes control wires.

One More Probe Type for Hams

Years ago, when amplitude modulation was the most popular voice mode, amateurs built an RF detector as an oscilloscope probe add-on. Shown in **Figure 4.11**, this is nothing more than a diode detector that recovers the amplitude modulation of a transmitter. This diode generally is germanium — the 1N34 being the most popular — since germanium diodes have a lower junction voltage than silicon. Today such a probe is still useful for an AM signal, but not very useful for SSB. However it is very handy to see the keying envelope of a CW transmitter.

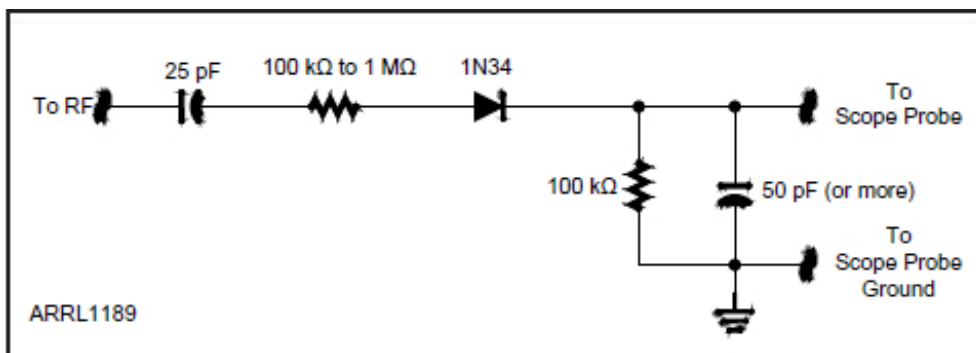

Figure 4.11 — A simple probe add-on was often used to display the modulation envelope of an AM transmitter. In practice the 50 pF output capacitor may be increased to provide a smoother display.

Chapter 5

Scope Sections in Detail

Years ago, if you wanted to apply for a US patent, you had to supply a drawing of the *physical mechanism* of your device. In fact, in the 19th century the patent office might even require you to bring in a working model. As industry moved more and more into the digital world, to a good extent more and more inventions were based on mechanisms that did not exist physically, but were made up of software programs.

At first the US patent office would say “no way.” But as their requirements and their understanding increased, as did the digital abilities of patent applicants, the laws and rules changed. The office started to grant US patents on devices that were at least in part constructed in software.

We have a similar situation here. To examine the critical sections of oscilloscopes, we use names of the sections that relate to hardware-only construction. But just about every section can be constructed in either hardware — with its advantages and limits — or in software with corresponding advantages and limits, or both.

As this chapter goes through the scope sections, it will generally discuss a hardware version of each section and a software version. Hardware scopes are still being sold in large numbers, especially where reasonably good performance is desired at a lower cost. Both hardware and software implementations — and combinations of both — have advantages and disadvantages.

Functional Block Diagram

Usually, for a piece of electronic equipment, the block diagram that most people are familiar with shows how the various hardware blocks are interconnected. The *functional block diagram* of an oscilloscope in **Figure 5.1** shows how the various functions are interconnected. The diagram includes both straight hardware-implemented oscilloscopes and the various configurations of digital signal processing based oscilloscopes.

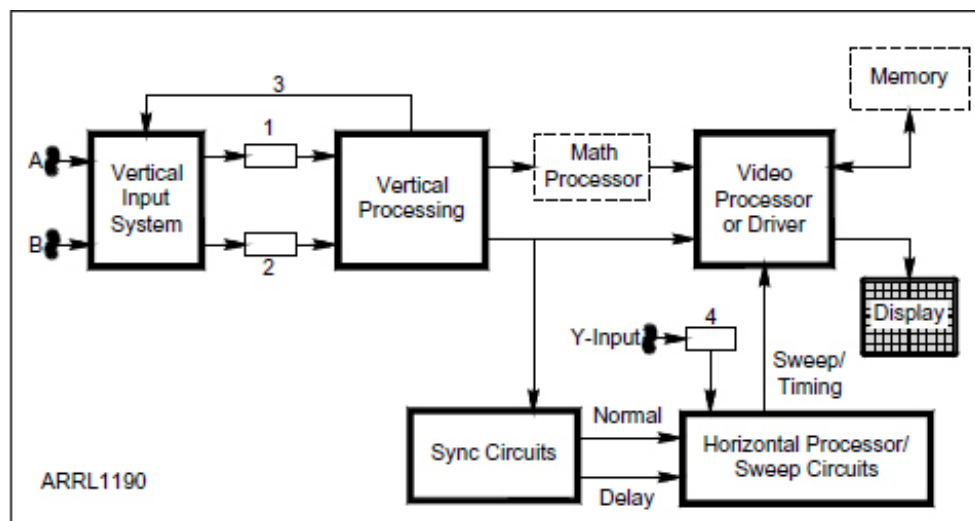

Figure 5.1 — Both analog and digital oscilloscopes contain the same basic functions; only the added features vary from scope to scope.

Two input channels, labeled A and B, are shown on the left. On the right is a pictorial of a screen representing both a straight cathode ray tube (CRT) display and a modern digitally driven flat panel display. The blocks labeled 1 and 2 represent the position of either one or two *analog-to-digital (A/D)* converters, as found in a digital scope. The additional A/D converter, labeled 4, is discussed later in this chapter. The dotted section labeled MATH PROCESSOR is found in many digital scopes that use a microprocessor or are PC based. As long as you have the computing power, the ability to do simple and advanced calculations and measurements on input waveforms comes almost free!

The other box shown in dotted form represents data MEMORY. This is again an almost free function,

available with digital processing. At the bottom of the figure, the concept or idea of the SYNC CIRCUITS block remains the same for old and new analog oscilloscopes and digital oscilloscopes, but the HORIZONTAL PROCESSOR/SWEEP CIRCUITS block is very much different between the two technologies.

Vertical Functions

Chapter 6 will discuss in detail the various input modes available in many oscilloscopes. The corresponding functions are shown in **Figure 5.2**. In a strictly analog oscilloscope, the two main blocks are a set of very precise — the degree of precision depending on the cost of the scope — analog amplifiers. They are designed to keep an exact amplification factor and have low dc drift.

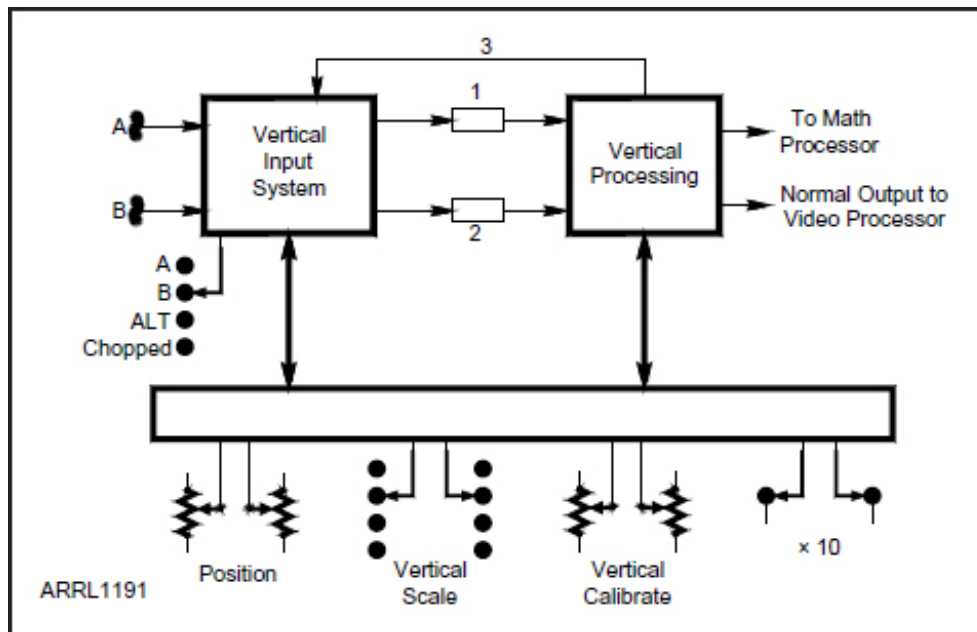

Figure 5.2 — The input section of a scope allows selection of inputs, adjustment of the height and the position of the scope trace, and calibration.

This input mode control has four choices — A, B, ALT and CHOPPED. Details of ALT (alternate) and CHOPPED are discussed in Chapter 8. Below the control block are pairs of controls, one for each input channel. POSITION moves the trace up and down and VERTICAL SCALE sets the gain — 10 mV/cm (millivolts per centimeter), 0.1 V/cm, 10 V/cm and so on. But after these there is a variable calibration control (VERTICAL CALIBRATE) that allows you to set a scale in between the fixed values. Often this causes a problem. If this control is not turned to one end — its CALIBRATE position — the vertical scale is not correct. To add further flexibility, the X 10 control changes the scale by a factor of 10 — usually used in conjunction with the X 10 switch on the probes.

In a digitally implemented scope, the first block is a set of analog amplifiers, feeding either one or two A/D converters (blocks 1 and 2). With a dual channel scope you would expect to see two converters, but if the scope bandwidth is low enough or the A/D converters fast enough (see Chapter 8 on scope specifications) just one A/D may be shared, alternately converting channels A and B. After this conversion the vertical processing is strictly digital, and there may be a feedback loop (shown here as 3) to stabilize the analog amplifiers.

On the right of the figure is the output to the video processor or display system. The second functional output (TO MATH PROCESSOR) represents the output to the various measurement and math functions that may be done before or on the displayed waveforms.

Horizontal Processor and Sweep Circuits

The classic oscilloscope explanation, dating back to the original scopes in the 1930s, had a diagram for the horizontal section consisting of a sweep waveform such as that shown in **Figure 5.3**. A voltage is applied to the horizontal plates of a CRT, and by increasing the voltage the trace on the screen moves from left to right. At the end of the trace the input signal to the vertical section is blanked, and the short section of the waveform, labeled

RETRACE, brings the trace on the screen back to the left side.

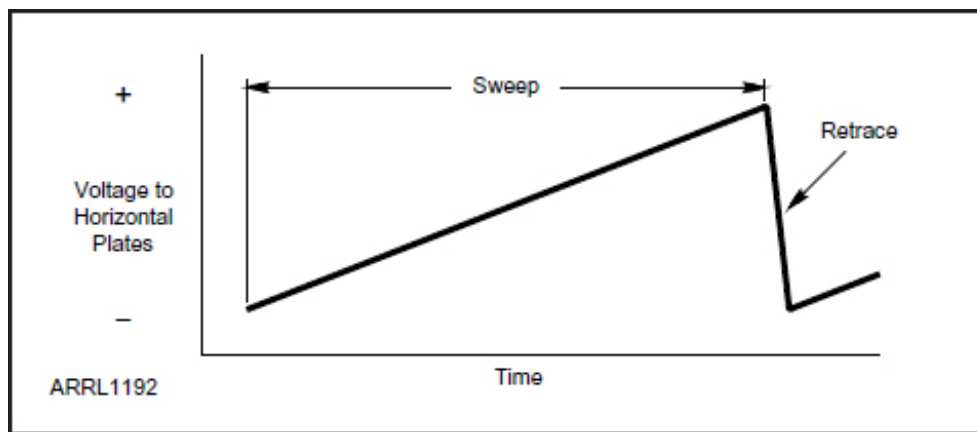

Figure 5.3 — This standard voltage sweep waveform is used in analog oscilloscopes; in digital scopes it is replaced by software commands.

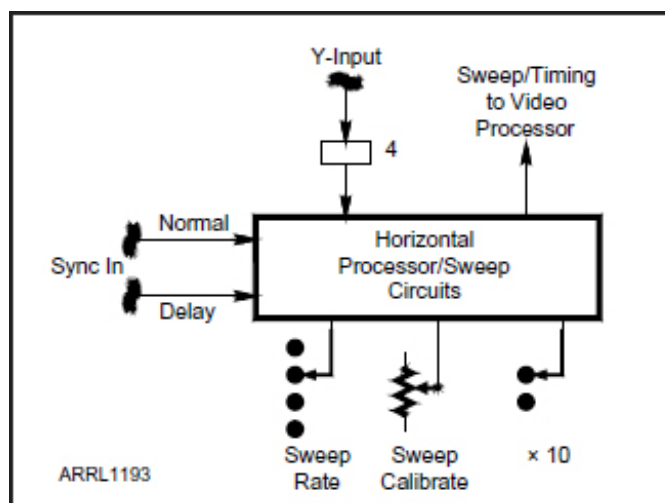

Figure 5.4 — The horizontal section of a scope has the same functions whether implemented in hardware, software, or a combination of both.

Whether digital or analog, today's scopes look functionally like the block diagram in **Figure 5.4**. A multiposition switch sets the sweep rate (1 $\mu\text{s}/\text{cm}$, 10 $\mu\text{s}/\text{cm}$, 5 ms/cm as examples). Just as in the vertical section, a calibration control may be used to set sweep rate values in between the fixed sweep settings. But once again, when a calibration control is part of the scope, it has to be set to the calibrated setting (usually marked at one end of the control) for the fixed values to hold. In addition, for convenience, often a switch labeled $\times 5$ (times 5) or $\times 10$ (times 10) is supplied.

Two inputs are shown from the SYNC section. The NORMAL input usually triggers — starts — the sweep. More capable scopes provide a delayed sweep. As shown in **Figure 5.5**, a *bug* appears on the screen, intensifying the video at the point you pick past the start of the displayed waveform. For example, suppose you want to get a good look at the fall time of your Morse code keyer waveform when sending a string of dots.

You would set the main sweep at perhaps 100 ms/cm to show at least one complete *dot*, both the rise and fall of the voltage. Now you would move the bug to the falling edge (**Figure 5.6**), select a faster sweep rate (perhaps 10 $\mu\text{s}/\text{cm}$) for the delayed sweep, and put the delay sweep on. At this point you would see the falling edge, at the faster sweep rate you selected, thus allowing examination of this edge in more detail.

Some scopes provide an additional input to the HORIZONTAL PROCESSOR. There are several measurements when two voltages are compared (see Chapter 7) against each other. One voltage input is sent to the vertical axis through Channel A or Channel B and the other into the horizontal axis through the Y-INPUT. In this case no sweep voltage is used. This Y-INPUT goes directly into the horizontal section of an analog scope but must go through an additional A/D converter (block 4) in a digital scope.

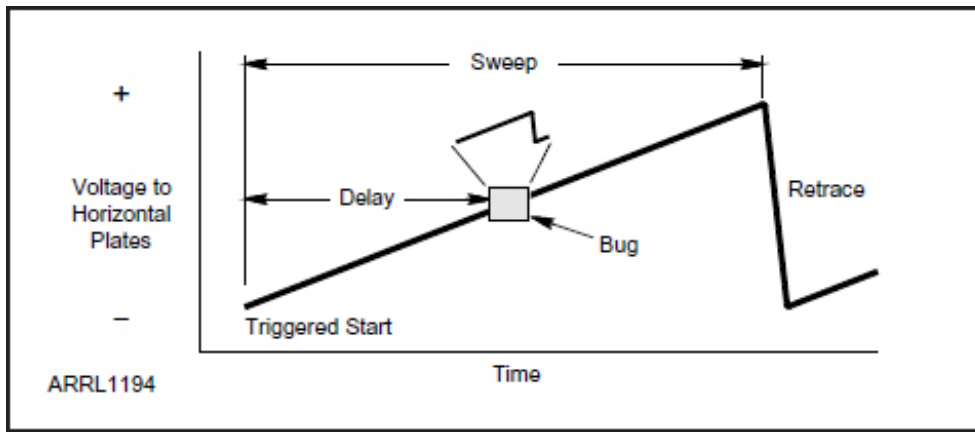

Figure 5.5 — When delayed sweep is selected, a point on the trace — often called a bug — is intensified to show what portion of the trace will be expanded.

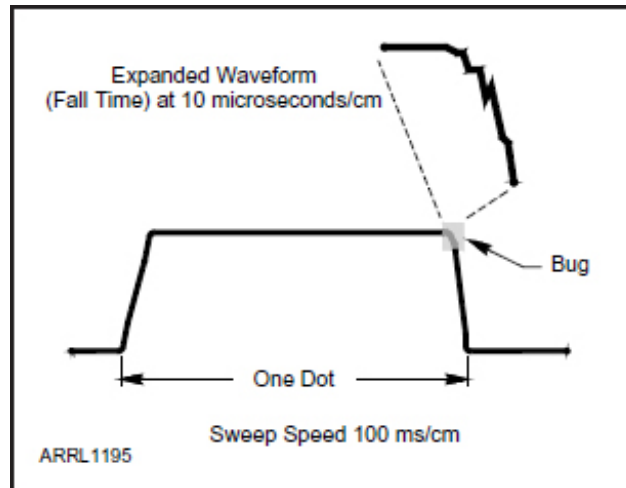

Figure 5.6 — Turning on the delay and expansion allows a close look at the selected part of the waveform.

Most of the preceding explanation appears to apply only to analog oscilloscopes, but it also applies to digital oscilloscopes. As you will see in a following section on the VIDEO PROCESSOR AND DRIVER, the voltage values sent to the vertical section are read out of memory starting at the memory location that corresponds to the time of the sweep start, and read out at a rate corresponding to the sweep rate selected. Instead of controlling analog circuits, the controls described in Figure 5.4 are actually software commands to set the speeds and functions.

Sync Circuits

Perhaps the most important parts of any oscilloscope are the synchronization circuits. No matter how high the bandwidth, no matter how good the display resolution, no matter how accurately a waveform is presented — if you cannot get an stable, repeatable display you cannot see the waveform under test. The SYNC CIRCUITS (Figure 5.7) and controls make the practical difference between being able to see what you want to see or not.

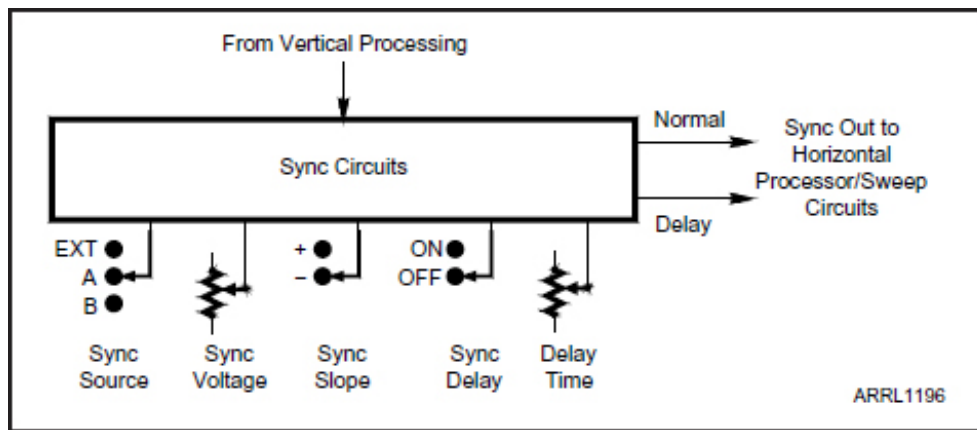

Figure 5.7 — On some oscilloscopes, the sync controls have other names. The objective of this section is to select a point on a waveform and generate a pulse to start the horizontal sweep.

The vertical signals (Channels A and B) are sent to the sync processor. In an analog system, this block is a set of comparators, trigger circuits, time delay circuits, and pulse generators. In a digital scope the same function is carried out by examining the stored data — in other words the incoming waveform has been stored in a digital memory, and the values processed.

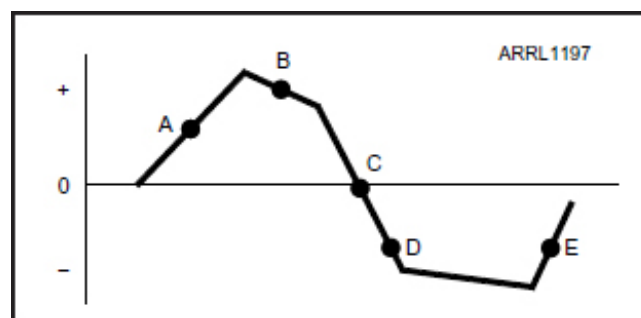

Figure 5.8 — This random waveform shows five possible points to select for the sync pulse and sweep start.

Whether the controls shown are actually physical switches and variable resistors or software commands, their effect is the same. The input to the SYNC CIRCUITS comes from the vertical processing channel. A selection is made — Channel A, Channel B or an external signal through a separate connector. In a digital system this external connector would go to a *Schmidt Trigger* circuit or other circuit to result in a squared-off digital pulse.

The operation of the SYNC VOLTAGE and SYNC SLOPE controls is illustrated in **Figure 5.8**. The various combinations shown are:

- A — positive voltage (value selectable), positive (rising) slope
- B — positive voltage, negative (falling) slope
- C — Zero crossing voltage
- D — negative voltage, negative slope
- E — Negative voltage, positive slope.

Since the voltage selection is variable, this set of controls usually allows you to set the sweep trigger point to any point on the incoming waveform.

The remaining controls — SYNC DELAY and DELAY TIME — were discussed in the preceding section. The location of the bug is set by the DELAY TIME control and expanding to the delay point (turning it on and off) is controlled by the SYNC DELAY switch.

There are two outputs. The NORMAL output provides the start point in time for the sweep, and DELAY output positions the bug. When delay sweep is turned on, the delay output provides the sweep start time. Keep in mind that this description is of the functions; how the hardware in any one scope actually does this varies with the scope design.

Video Processor and Driver

There is a considerable difference between the hardware and operation of the VIDEO PROCESSOR or DRIVER in the classical analog oscilloscope and the hardware and operation in a digital scope. Analog scopes are still readily available and are often selected for the simplicity, lower cost and wider bandwidth for the cost. A version of the classical analog video section and display is sketched in **Figure 5.9**. The video from the VERTICAL PROCESSING block simply goes to a video amplifier, one that provides symmetry — the ability to drive both positive and negative with respect to a reference such as ground. This amplifier is connected to the vertical plates and thus provides the vertical deflection on the screen.

The HORIZONTAL PROCESSOR/SWEEP CIRCUITS also requires a symmetrical amplifier, feeding this direct analog sweep voltage shown in Figure 5.9. This signal moves the beam horizontally across the screen. The other signal is a blanking pulse, for the duration of the retrace time in Figure 5.3. During this period, as the trace moves back to the left side of the screen, the blanking pulse puts a bias on the grid shown in Figure 5.9 that cuts off the video — thus no retrace is seen on the screen.

Digital oscilloscopes, although functionally very much identical, operate completely differently on a hardware basis. There are two general configurations — a self-contained digital scope, and one that plugs into and uses a personal computer or other digital device such as an iPad for calculations and display of the traces.

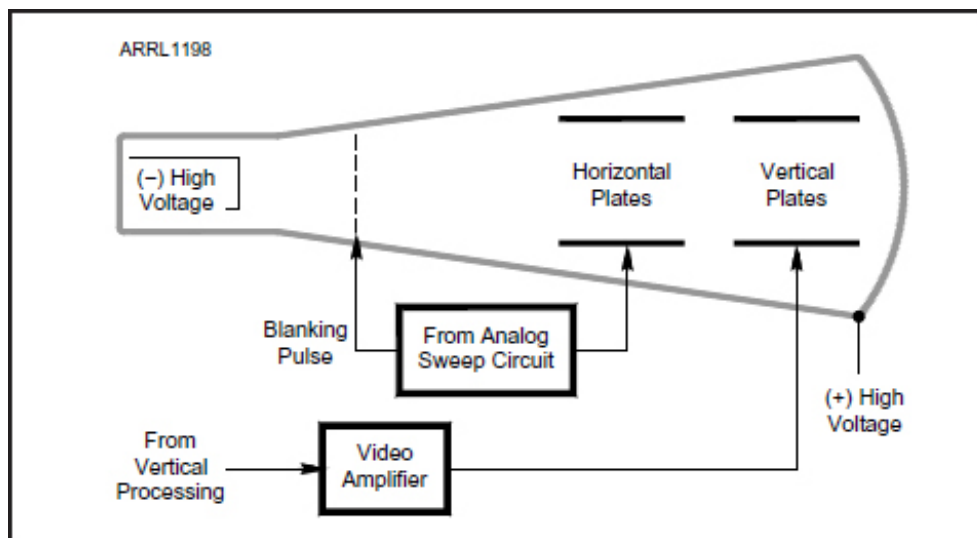

Figure 5.9 — For many years and up to and including today, this is the typical block diagram of an analog oscilloscope. The sweep voltage is applied to the horizontal deflection plates and the input voltage to the vertical deflection plates.

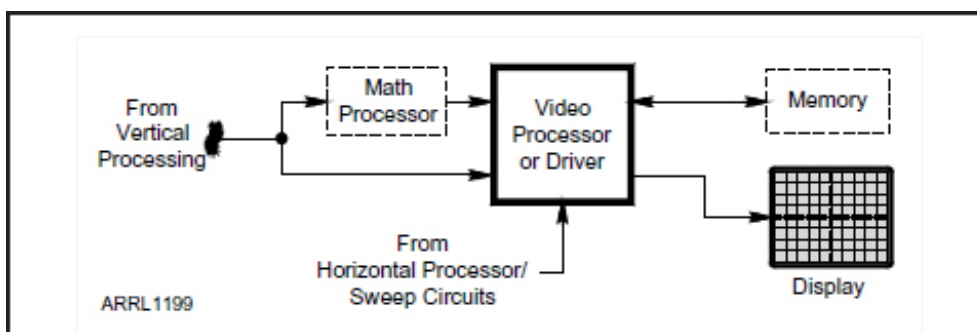

Figure 5.10 — Digital oscilloscopes are best shown by this functional block diagram. The hardware is actually a microprocessor, digital memory and video driver — in other words, part of a personal computer or equivalent.

Figure 5.10 represents this functional configuration. It is based on storing the incoming waveforms in digital memory after they have been converted from analog voltages to digital words in the vertical input system. How data is stored in memory to be displayed is very dependent on the particular hardware device. In *Windows* PCs, video memory can be a part of main memory or it can be a separate, high speed memory bank on the video card. Apple products have their own techniques, as do Android and other digital devices. However the waveform storage concept can be understood by looking at **Figure 5.11**.

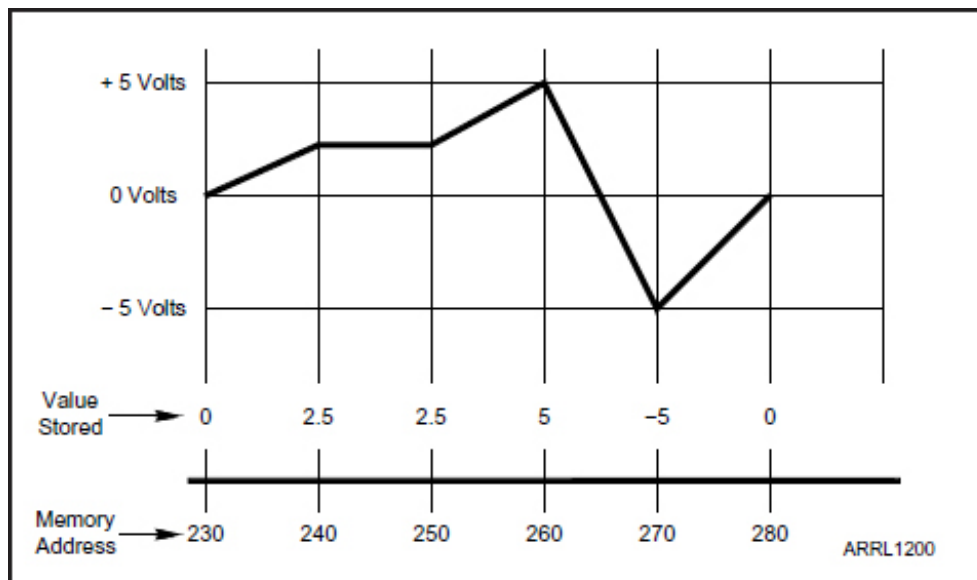

Figure 5.11 — If you were able to see into the memory, the stored values would consist of a set of 1s and 0s — programming tools would show them as hex values. The memory addresses would also show as hex values.

At the top is an analog waveform that has been converted to a digital number by the front end A/D converters. Each of these converted numbers become a digital word, and as seen at the bottom of the figure each corresponding stored value goes into a memory location. All memory systems have an address for each part of memory, and in the figure a set of address starting at address 230 through address 280 is seen to hold the stored values for one channel.

This is a very simple linear system, and various techniques for video compression and memory location selection are used to speed up video display. Whatever the real storage technique used, these values can be commanded to set a vertical position on the display screen as the horizontal processor provides a horizontal position — the horizontal processor provides the equivalent of a sweep. Call the sequence of values quickly out of memory and you have a fast sweep rate — say 10 $\mu\text{s}/\text{cm}$. More slowly and you have a slower rate, say 100 ms/cm .

Thus the stored value provides the vertical position on the screen and rate and call-out speed from memory provides the horizontal timing and position. In Figure 5.10, MEMORY is shown in a rectangle — it is actually integral to the video processor.

What About Math?

Earlier in this chapter there was a statement that in a digital scope, math calculations come almost free — that is, no additional hardware is required. Looking at Figure 5.11 you can see how the MATH PROCESSOR, also shown in Figure 5.10, can be used to find the peak value or minimum value, or to select all points and calculate an average — all because the data exists in memory. If the Channel A waveform is stored in memory locations 230 to 280, and the channel B waveform is stored in memory locations 330 to 380, forming the function $A+B$ now requires only a software command to add the value in memory location 230 to the value in location 330, the value in 240 to the value in 340, and so on. Since large amounts of incoming waveform data can be stored, much more complex math functions, such as spectrum analysis, can be done in software with the results displayed on the screen.

Does the Display Type Matter?

Plasma, LED backlight, thin film ... a host of display types are available. However the display now has to be matched to the processor and not to the oscilloscope functions. This means that the video card (or integral video section), for example on a PC, is matched to the display. If what is often termed the *native resolution* selected, the particular display used will not affect the oscilloscope function.

There are, of course, several possible exceptions. If a digital oscilloscope front end is mated with an older personal computer using 640×480 resolution, your results may not be all they can be. Another possible

exception is the set of miniature oscilloscopes that mate to smartphones or tablets. Here the problem is not so much display resolution — you won't see the difference — but the screen size, even with a 8 or 10 inch tablet, may restrict what you can see.

Storage

Most of the time the ability to store a waveform on the screen is not of primary importance. There is one case, however, where it becomes very important. In general an oscilloscope is used to look at repetitive waveforms. For a digital oscilloscope, memory is built in. Looking again at Figure 5.11, if these memory locations represent a full screen of information, when memory location 280 is filled the entire set is normally (and very quickly) cleared and the new incoming waveform refills locations 230 to 280. The process repeats over and over, and storage of a waveform is not important.

There is one very important case where storage is required — when you want to examine an transient effect that only happens once. Then you would like to fill up 230 through 280 and freeze — hold on to — the result. Again, this ability comes free with digital implementation.

There were and still are analog scopes with storage capability. There the storage is not in the circuits but in the CRT. By adding a mesh or screen just behind the phosphor layer on the front to the CRT and some unique *electron flooding*, the actual storage is accomplished in the phosphor layer on the screen. To see an example of this technique, set your Internet search engine to *typotron* or *SAGE System Display* and you can see the details of one application. These analog storage scopes were, of course, quite expensive and very rare outside of industrial laboratories or military hardware.

No-Hardware Scopes

Since some digital oscilloscopes plug into a PC, and use the PC for all the processing and display, why bother with the digital front end? You already have an input port for audio on your sound card; why not use this as the scope input? If you search the Internet you can find several such software packages — and for the most part they do work. But there are several disadvantages.

First of all your input is restricted to audio frequencies — perhaps 10 Hz to 20 kHz. Next, you have to protect your sound card. Protection is discussed in Chapter 7 of this book and a typical protection circuit shown. But a very important restriction on these software-only scopes is distortion.

If you are looking at a plain sine wave, and it is within the bandwidth of the audio card, your results will be reasonable. If, however, you are looking at a square wave, triangular wave or any repetitive waveform other than a sine wave, there will probably be considerable distortion.

Without getting deeply in to the math to explain this, a technique known as *Fourier analysis* shows that every repetitive waveform consists of a set of sine waves, each at a multiple of the waveform frequency and with a certain amplitude. As an example, suppose you want to look at a perfect square wave at 5 kHz. This square wave is actually made up of the addition of sine waves at 5 kHz, 15 kHz, 25 kHz and other odd multiples of 5 kHz — each with a precise amplitude.

Since the no-hardware scope does not show sine waves above 20 or 25 kHz accurately, instead of seeing a perfect 5 kHz square wave you could see a very distorted 5 kHz waveform with rounded top and sloping sides instead of the nice, rectangular square wave you expect. No-hardware scopes do have their place in audio-only applications. They are inexpensive (often implemented in free software) and fun — but don't expect to use on in place of a hardware-based scope.

Chapter 6

Input Modes

What you can see on your oscilloscope is controlled to a large extent by what *input modes* are available, and the input modes in turn are controlled by — as you might guess — both circuit design and the oscilloscope controls available. In addition, the real-life design considerations that went into the scope provide further capabilities and limitations.

In this chapter, to illustrate various points we will use pictures of vintage Tektronix oscilloscope input modules. This series of scopes consisted of a base unit with replaceable, often single purpose plug-in units for the front end of the scope. We will also look at today's modern designs that have combined both the capabilities and controls of the older scopes — an objective which just was not reachable back in the vacuum tube days.

As an example, suppose you need a single, very high gain input capability with very precise calibration. An accurate, high gain capability requires accurate and long lasting calibration. In addition, extra bandwidth reduction may be required to keep system noise from corrupting the waveform you wish to see. Therefore, it is not just a matter of designing a high gain input amplifier. It must be stable, have accurate and lasting calibration, and exhibit a degree of noise immunity. From this point of view, the design of an oscilloscope front end is not very much different from the design of a good preamp for your Amateur Radio receiver — low noise, proper bandwidth, stable amplification and so on.

A number of amateurs discovered this similarity with later model Heathkit oscilloscopes. Prior to the demise of the company, Heath offered a set of solid-state oscilloscopes with bandwidths ranging from 5 MHz to 35 MHz (and possibly higher with some models.) Hams who bought and built these kits discovered they were building circuits — and having to calibrate them — just as they would an amateur receiver.

Input Modes

As might be expected, in a competitive world, different manufacturers pick and publicize their scope capabilities with names that often do not match those of their competitor's capabilities for the same function. Here is a list of common input modes under generic — commonly accepted — names. Most often when there are two available input channels, they are referred to as channel A and channel B.

- Ground (reference)
- Ac Coupled (selectable independently for each channel)
- Dc Coupled (selectable independently for each channel)
- Inverted
- Differential (no ground reference)
- High Gain
- Fast Rise Time
- Dual Trace
- A/B Alternate
- A/B Chopped
- A+B (A plus B)
- A-B (A minus B)
- High-Z (high impedance) Input
- 50 Ω Input
- Wide Band
- Digital Inputs
- Multi-channel
- Audio Only

Some of these input modes are fairly obvious just from their titles; other require a bit of explanation as to benefits and limits.

Common Input Selections

Independent of the oscilloscope type — hardware only, hardware and software, and software only —

there are almost always three input selections. These are pictured in **Figure 6.1**, where the lever switch on the left hand side is used to select ac inputs only, dc inputs only or a ground reference. The ground reference is used to set a baseline of 0 V input, so that everything seen after that can be referenced to this value (specifically this line as seen on the screen.) The other two selections, ac coupled and dc coupled, are exactly what their names imply.

Suppose you are looking at a waveform that consists of a dc level of 30 V, on top of which is riding a 1 V sawtooth. By first selecting GND (the ground reference) and positioning it at the bottom of the screen you know where the vertical position of 0 V is. Next, by selecting DC (dc only) position, the waveform will show up in its entirety, assuming you have the vertical voltage scale set high enough. However the 1 V sawtooth will be very hard to measure.

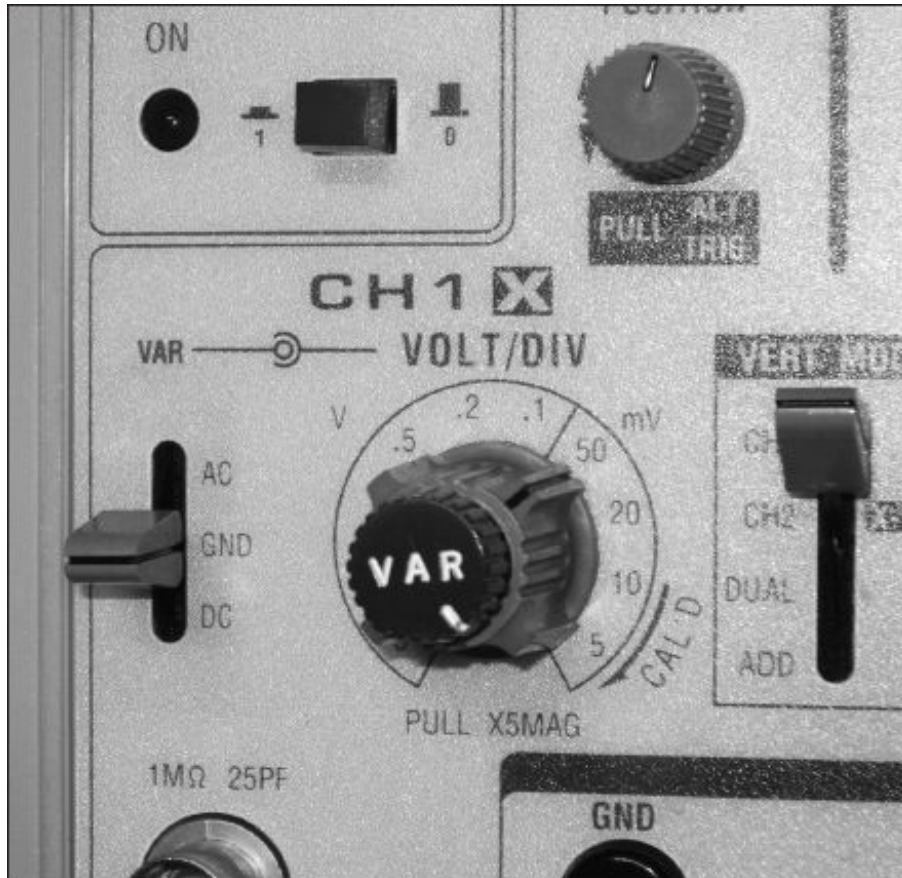

Figure 6.1 — The left-hand switch shows the standard three choices for selecting the input signal — AC, DC and GND. The GND position allows you to set a reference level for the display.

Next when you select the AC (ac coupled) position, the dc level disappears and you can readjust the voltage scale to better see and measure the amplitude of the sawtooth.

These input selections are set independently for each input channel — that is, there is another lever switch (not shown) for the second channel. **Figure 6.2** shows the on-screen controls of a scope using a personal computer, with the coupling controls at the lower left. The input controls are duplicated for each of the two channels.

Some oscilloscopes also provide an INVERTED selection that allows you to display a signal with low voltage at the top of the screen and high voltage at the bottom. This is generally available when the scope also has some sort of integral math function.

Figure 6.2 — This scope uses a mouse and an on-screen display to select the inputs as well as other functions. Channel 1 and Channel 2 are controlled independently via buttons in the lower left section of the display as shown in the closeup.

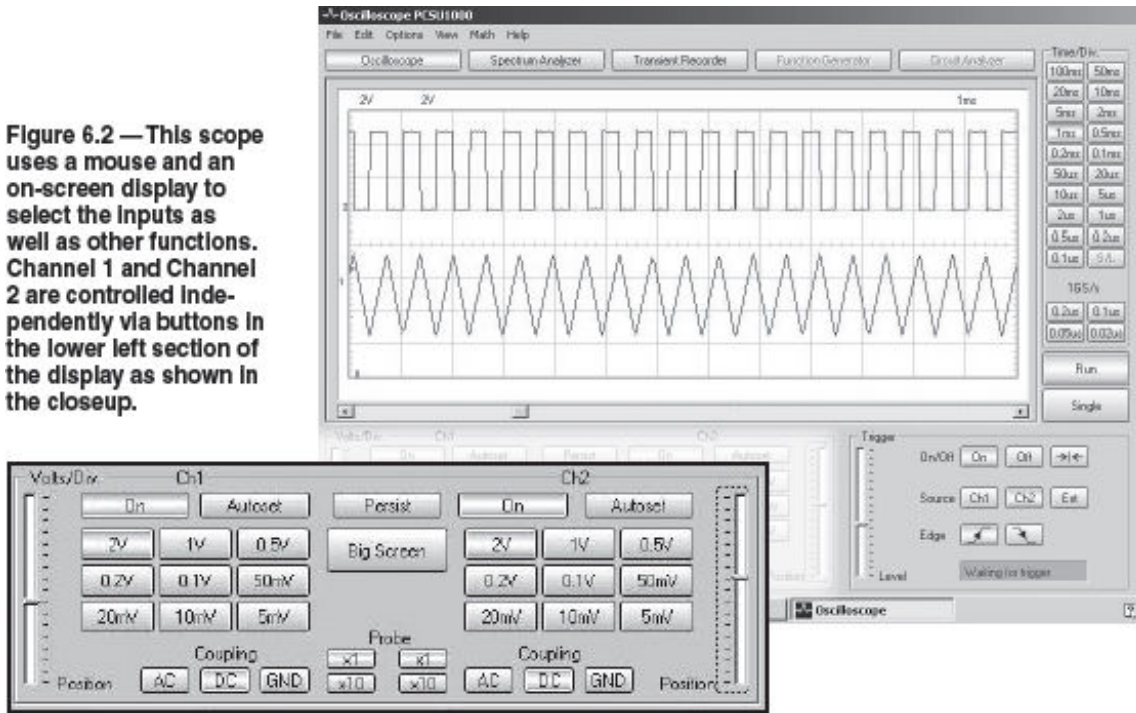

Single Channel Modes

Depending on the intended use, age of the scope, and cost, some oscilloscopes provide specific specialized features on either a single channel input or multiple channel inputs. Not all of these features are compatible with each other.

Previously we mentioned that high gain front ends may not be compatible with a system looking for high frequencies. Where the best frequency response is needed, manufacturers may refer to this characteristic as *Wide Band* or *Fast Rise Time*. **Figure 6.3** is the front-end plug-in of a Tektronix scope of a few generations ago, where the design was optimized for fast rise time.

Although Wide Band and Fast Rise Time are similar, they are used and measured differently. Wide Band refers to the highest frequency that displays (generally) at least 70.7% of the correct amplitude value of a sine wave. Fast Rise Time is important for digital measurements only, and fast is in comparison to the rise and fall time of a digital pulse you want to measure.

Today the specifications of a scope would tell you its characteristics in these areas assuming the manufacturer includes it in a full listing of capabilities.



Figure 6.3 —This vintage Tektronix FAST-RISE plug-in front end provides very fast response to rising and falling pulse edges, useful for digital information where the pulse edges are important.

While most scopes are designed to have minimum loading on a circuit — that is the presence of the scope does not affect the circuit performance — some scopes are specifically labeled *High-Z Input*. Normally the input of a moderate value scope would look like a 1 M Ω resistor in parallel with 10 pF. A High-Z Input would be several 10s of megohms, but the input capacitance is still generally at least 5 pF. Usually the High-Z Input requires a special probe, matched to the scope design.

For work on transmission lines, where any impedance mismatch may affect the measurement, there are specialized scope whose inputs look like a pure 50 Ω resistor. Thus they can act as a matched load (for very low power levels) on a port or splitter attached to the line.

Dual Channel Inputs

While the early oscilloscopes described in Chapter 1 concentrated on allowing a single signal to be seen, scope capability has grown to include, for just about all models, a two-channel or *dual-trace* input. Again, using a very popular obsolete Tektronix plug-in front end as an illustration, **Figure 6.4** shows the identical controls for the two channels. A five position MODE switch selects the channel or channels to be displayed.

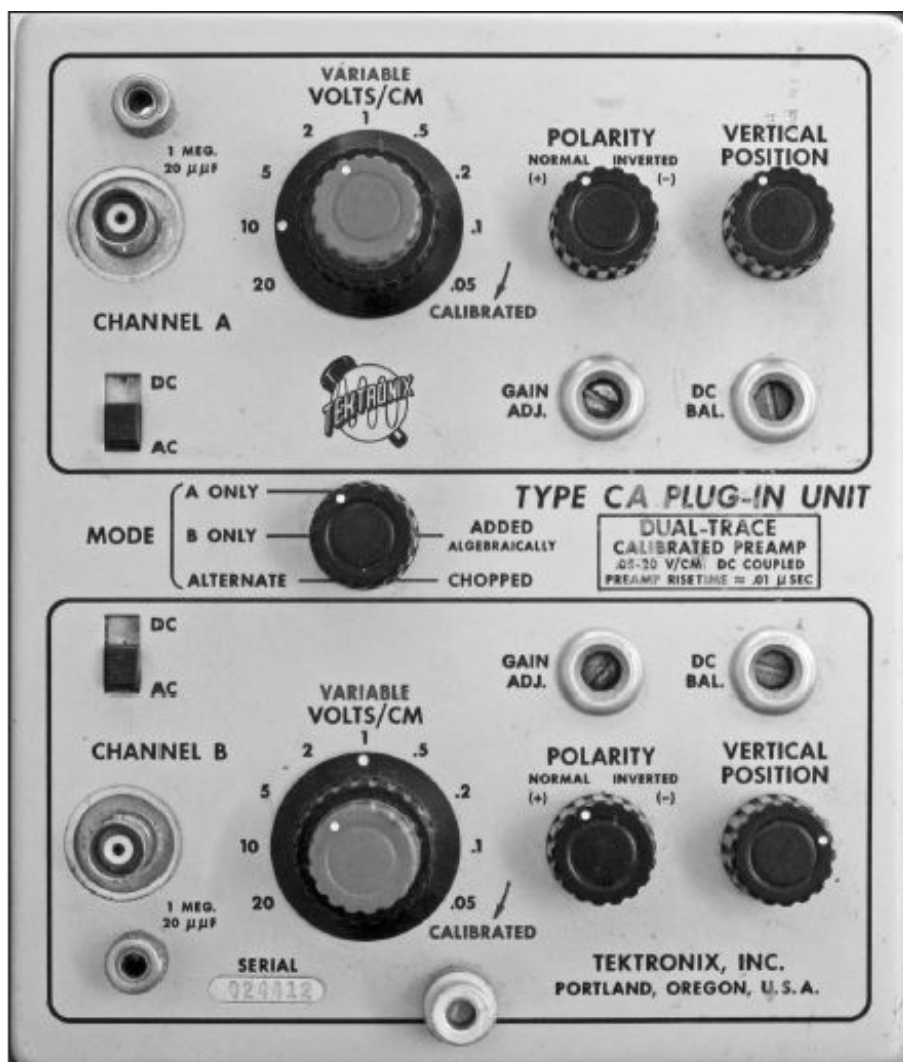

Figure 6.4 — Today's dual channel oscilloscopes owe their concept to older scopes such as this one that provided two complete sets of mechanical switches for each channel. Compare this vintage Tektronix dual channel front-end control unit with the modern software version shown in Figure 6.2.

The first two positions allow you to see one channel only, either A or B. The third position, ALTERNATE, can be very misleading. What you see depends on the sweep trigger section (as described in Chapter 5). If the sweep is triggered by one channel and that channel only, the horizontal position or relative timing of the second channel may not be what you observe.

The result of modern dual-channel inputs is illustrate in **Figure 6.5**, where a square wave is shown in channel A, triggered by the square wave, with a triangular waveshape in the lower trace. Each trace provides its own trigger, so although you see both in stable positions, they are not necessarily occurring in time relative to each as shown.

To ensure that the two waveforms are displayed in correct time alignment, the CHOPPED function is often used. Here each waveform is sampled and displayed — one tiny increment in proper position for channel A, an increment for B, back to A and so on.

Generally, as long as the waveforms are very much lower in frequency than the chopped (or sampling) frequency, the switch back and forth is relatively invisible. However, in all cases, what you see is heavily dependent on what is effectively the synchronization of the sweep function.

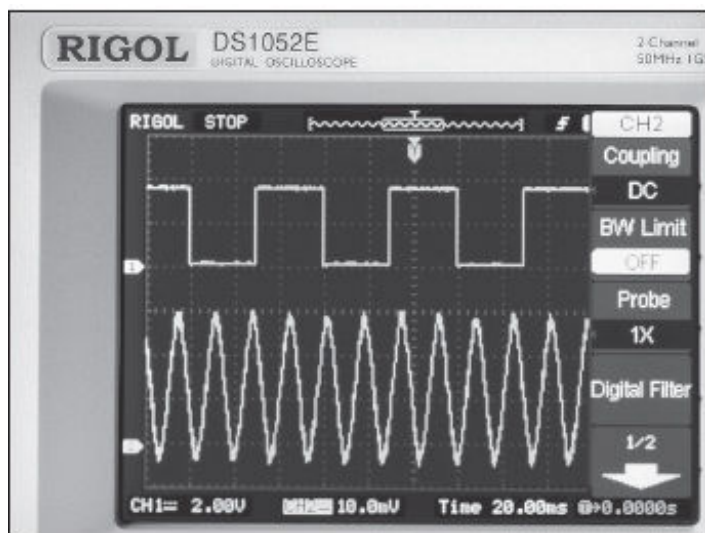

Figure 6.5 — Another approach to controls is the use of icons along the top, bottom and sides of the screen to show status (as shown in the closeup), but the actual selection is done by front panel controls.



The fifth position on the MODE switch, ADDED, is one example of mathematically combining the two outputs, in this case a simple addition.

Dual Channel with Arithmetic

The simple arithmetic function label shown in Figure 6.4 (ADDED) implies addition. However, both channels have POLARITY (NORMAL or INVERTED) selectors, which simply switch in inversion of the either or both waveforms. This function, in combination with the ADDED (ALGEBRAICALLY) mode position means the waveforms A and B can be combined in four possible ways: $A+B$, $A-B$, $B-A$ and finally $-A-B$.

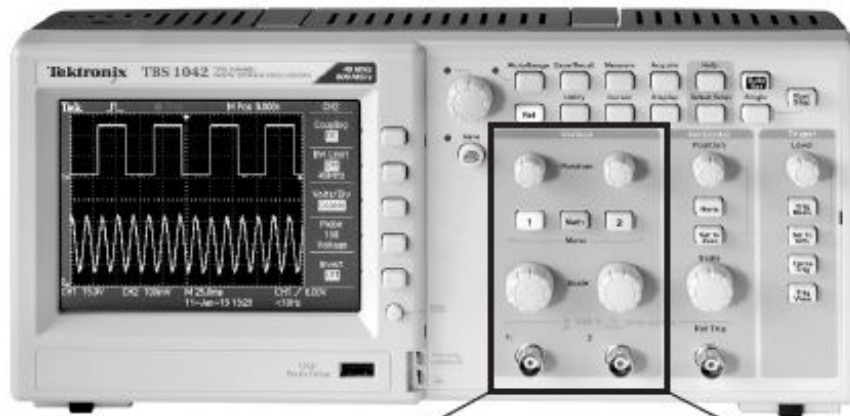
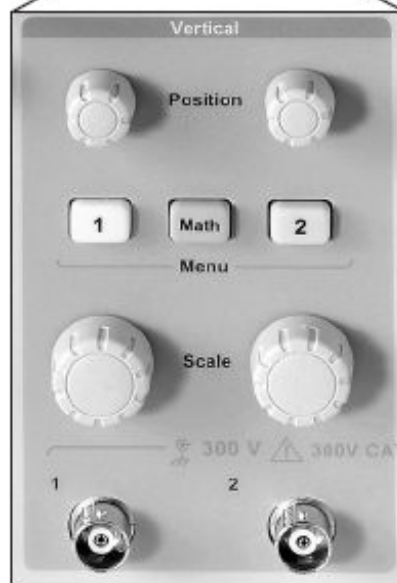

Figure 6.6 — A key button on this self-contained modern Tektronix oscilloscope is the one labeled MATH as shown in the closeup. It allows you to combine the input signal in a variety of ways, in addition to performing a number of mathematical operations and measurements on the signals.



A newer Tektronix oscilloscope, shown in **Figure 6.6**, has a control labeled MATH near the center of the figure. Here a number of combinations of signal (and calculations) may be selected.

One of the most valuable modes for design and troubleshooting modern electronics, especially where digital data lines are used, is the *differential* mode. The arithmetic described in the previous example has an inherent characteristic. For example $A+B$ is really $(A \text{ as compared to ground}) + (B \text{ as compared to ground})$. What happens if neither signal is referenced to ground, but they are referenced to each other? In fact introducing the ground connection may show noise and other extraneous signals that really do not exist on the line under test.

Figure 6.7 is a block diagram of a typical balanced line driver — it has four independent sections — A, B, C, and D. Looking at section A at the top left, a data waveform is connected to pin 1. The output is balanced and connected to pins 2 and 3. This output is not referenced to ground, but as shown one is the nominally labeled positive data output line and the other is the negative or return.

There are many such integrated circuits used with various configurations, but the common characteristic is the lack of a ground reference. At the other end of the line a complementary data receiver has two inputs per channel, and the output of the circuit is a single data stream for the channel.

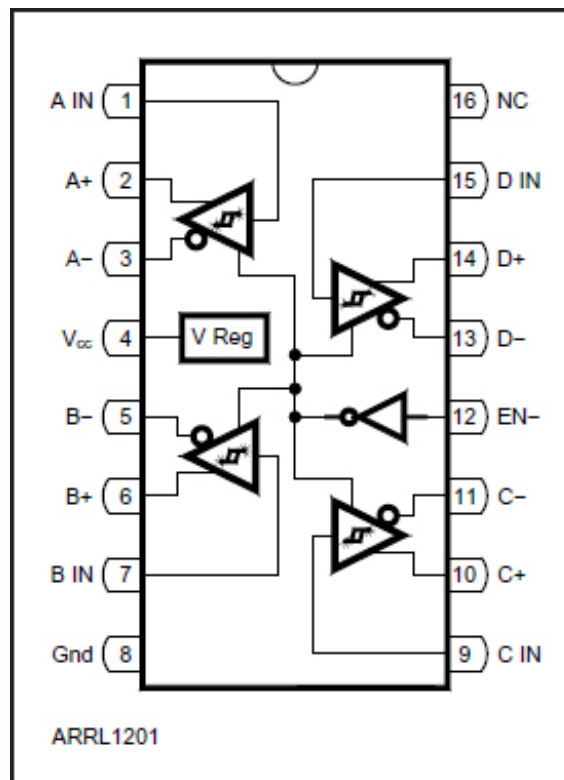

Figure 6.7 — To send signals from one printed circuit board to another or from one place to another, balanced line drivers such as this integrated circuit place the signal and return on two floating wires. Four independent drivers are packaged together here. The system ground reference is not used.

In a modern piece of electronics, where RF may be found, a designer may choose to send data from one printed circuit board to another using a differential driver and receiver to minimize RF pickup with respect to ground.

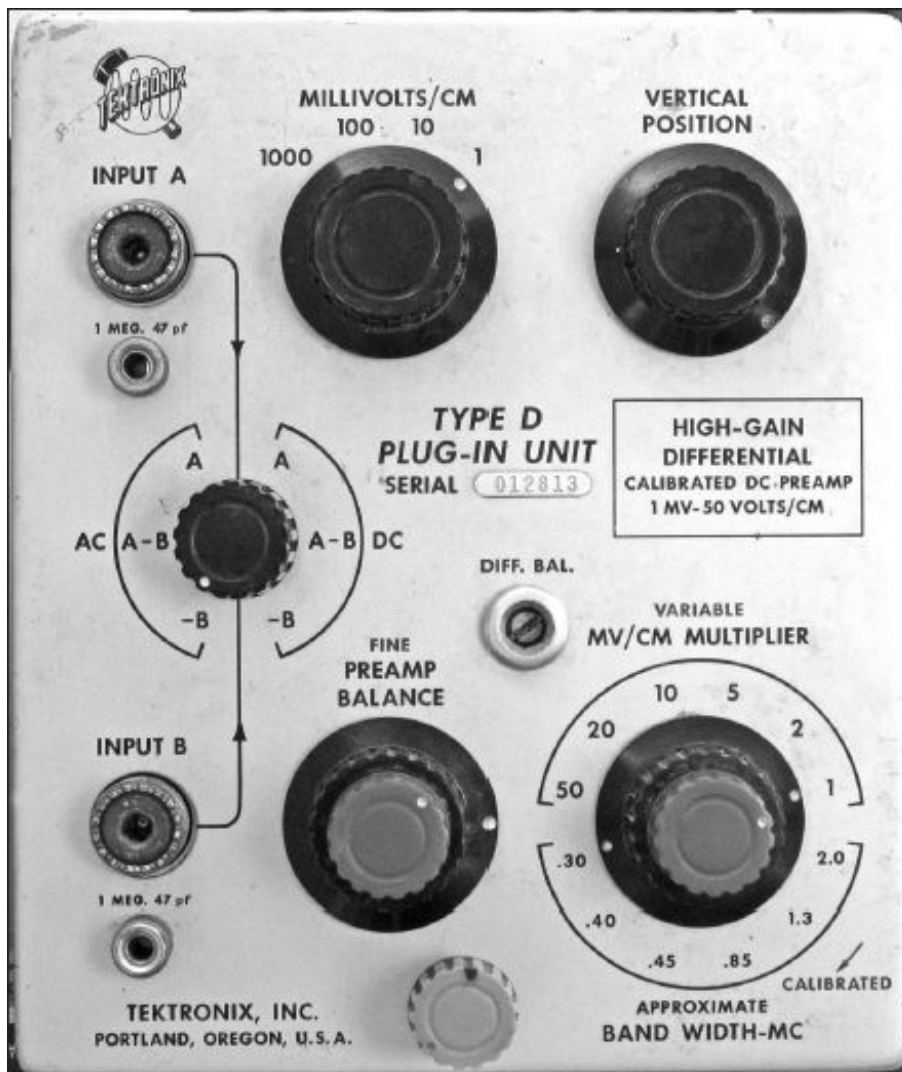

Figure 6.8 — Mechanical switches were used to select the signal inputs. In this vintage Tektronix plug-in front end, the basic function was differential, shown as positions A – B for either dc or ac input coupling.

Again using an old Tektronix scope as an illustration, **Figure 6.8** shows a high gain differential front end. Tektronix actually made two such differential front ends, this one called HIGH GAIN and a second called WIDE-BAND.

Special Modes

When you want to look at logic signals, a dual channel capability may not be enough. There are a few manufacturers of four channel scopes and possibly models with even more.

A newer approach is illustrated in **Figure 6.9**. As shown, the top two regular channels are not connected to any signals. This scope has four *logic signals only* input wires. In the figure, the four lower traces are inputs on these connections. Any one of these inputs can be selected as the sync source, which gives a good degree of flexibility in choosing what to look at.

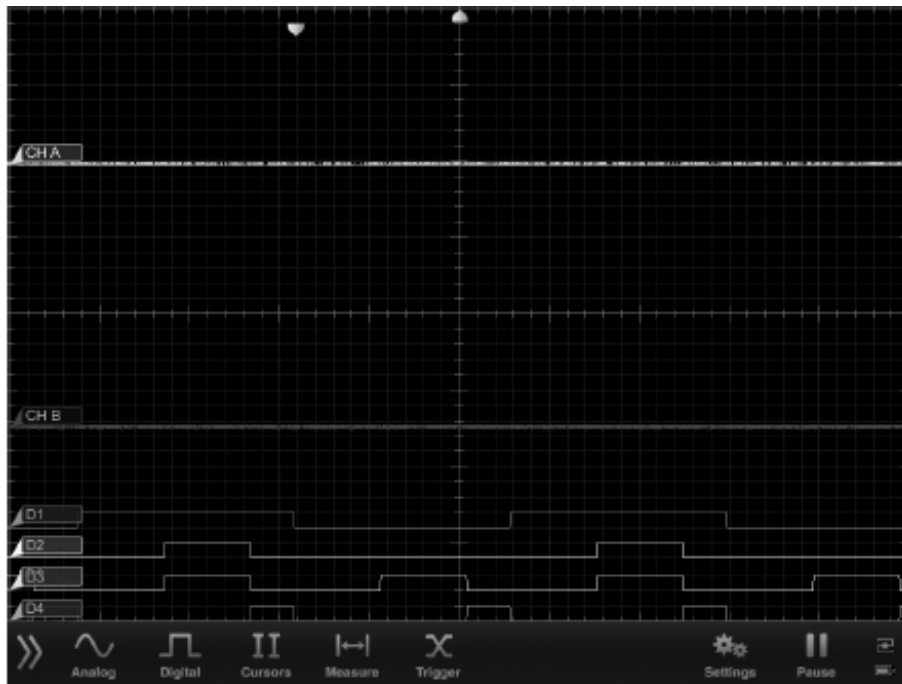

Figure 6.9 — The ability to look at more than two logic signals at once can be quite valuable. This display shows two analog inputs (Channel A and Channel B at the top) and four digital inputs — D1 to D4 — at the bottom.

One very specialized front end for a scope, which has no front end, is the software-only scope discussed in Chapter 7. This scope uses your computer and audio card. As a result its bandwidth is limited to the audio frequency range only — perhaps a few tens of Hz to 20 kHz. Several versions of the software are available online, mostly without charge. Although a direct connection to a sound card is possible, most users follow the online directions to build a small protection circuit for the sound card. One such circuit is included in Chapter 7.

Chapter 7

Let's Put a Scope to Work

Oscilloscopes are generally used for one of three types of measurements: amplitude (voltage), duration or time (frequency), and calculations. Most older scopes did not have the ability to do calculations, but as discussed in preceding chapters, as long as you have information in digital form and are using a digital processor (in other words a small computer), the oscilloscope can do a variety of calculations.

Amplitude Measurements

When most people think of using an oscilloscope, they envision a screen with a plot of the amplitude or voltage of a signal on the vertical axis of a screen, along with time on the horizontal axis. To make this primary plot on the display, there are several steps you have to take. It is very possible to overlook one of these steps, in which case the displayed waveform may mislead you and not represent the true picture of the signal.

First pick a voltage scale, and if there is a variable scale control, make sure the voltage scale selection switch is in the calibrated position. Looking at **Figure 7.1** you can see scale selection switches for channel 1 and channel 2. Notice that the center knob (labeled VAR) for channel 1 is in the full clockwise position, corresponding to the calibration position on the panel. The VAR knob for channel 2 is not in the same position, so as a result the voltage scale selected for channel 1 is correct but the scale selected for channel 2 is incorrect. It is very easy and very common to overlook checking this setting.

Check your probe compensation. Compensation, as noted in a prior chapter, only holds for the X10 setting

on the probe switch. If you are looking primarily at sine waves and RF, it is doubtful that (except for extreme maladjustment of the compensation screw) this adjustment will make much of a difference. Digital signals are a different story — just look at **Figure 7.2!** With compensation maladjustment, square waves, pulses, sawtooth and other linear waveforms may be shown far from their true waveshape.

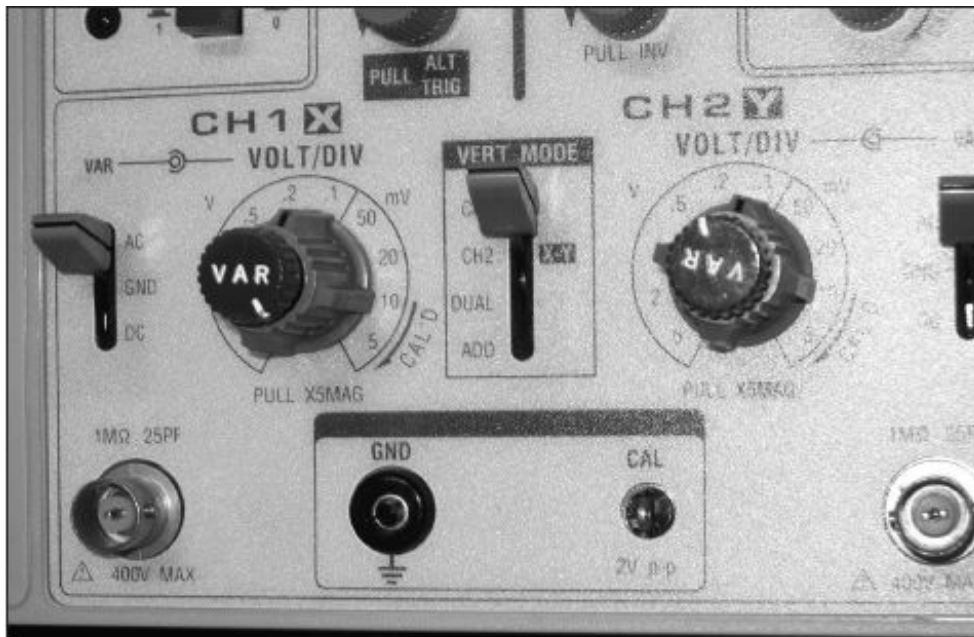

Figure 7.1 — Channel 1 is calibrated (VAR knob fully clockwise, in the CAL'D position), so the VOLT/DIV setting is correct. Channel 2 is not calibrated (VAR not fully clockwise), which can lead to false measurements.

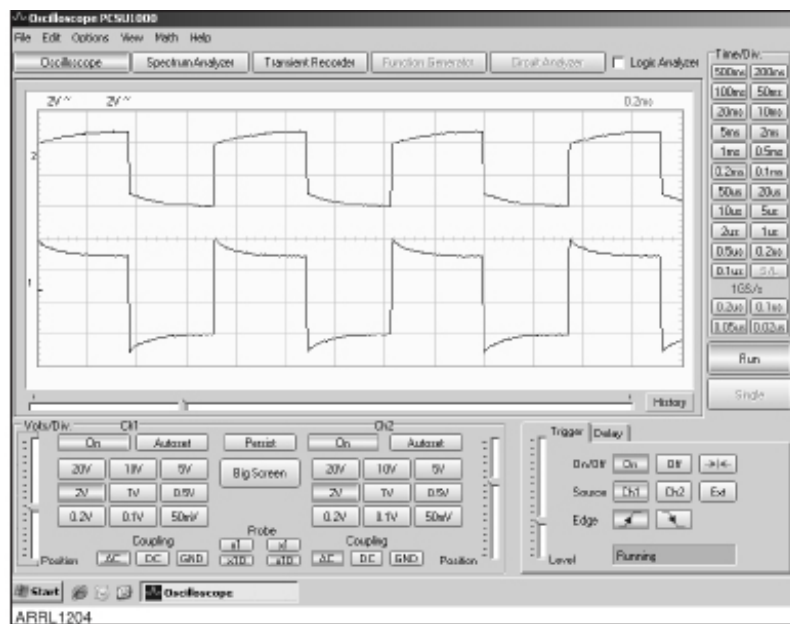

Figure 7.2 — If the probe compensation were correct, both of these square waves would have flat tops and bottoms.

Set up a zero reference. Most scopes have an input setting marked GROUND or GND; it is difficult to make a measurement if you do not have a reference.

Now you are in a position to make a voltage measurement. Count the number of centimeters (cm) on the vertical scale. You may have to move the horizontal position control (if there is one) or change the trigger point to get a good measurement on the subdivisions of the graticule. Multiply the number of cm by the voltage scale and you have your number — almost!

Now go back and look at your probe. Do you have it in the X10 position? If so, multiply your previous reading by 10!

A word of caution: It is easy to get confused when you compare a reading from a voltmeter with the measurement you just took on a scope and see that they are different and assume that either the scope or the

voltmeter is in error. Remember that most voltmeters measure RMS (root-mean-square) values, but you most probably just measured a peak-to-peak value on the scope. To get an equivalent value, take the peak-to-peak number, divide by 2 to get the peak value, and then multiply the peak value by 0.707 to get RMS. This simple conversion holds *only* for sinusoidal waveforms.

Another thing to keep in mind when measuring waveforms near the upper limit of the scope's bandwidth is that the generally accepted figure for bandwidth is the frequency where the measurement is off by 3 dB in voltage. That is, the waveform may show 3 dB lower than it actually is.

Alignment with a Sweep Generator

One very common voltage measurement using a scope is the alignment of an IF strip in a receiver or the measurement of an RF or audio filter. That requires a signal generator produces a signal at the frequency or frequencies of interest, or a sweep generator (a signal generator that sweeps its output signal over a range of frequencies).

As an example, assume the OBJECT UNDER TEST in **Figure 7.3** is a filter with a center frequency of 1 MHz. If we wanted to see the filter response from 900 kHz to 1.1 MHz, the sweep generator would be set up for its output frequency to vary from the lower 900 kHz limit to the upper 1.1 MHz limit. As the frequency changes, the sweep output voltage also changes, so every point on the horizontal axis corresponds to a frequency in the swept range. The RF voltage goes into the filter and the output of the filter goes to the vertical input of the scope.

The net result is a plot seen on the scope display that shows the filter characteristics over frequency. See **Figure 7.4** for an example filter response plot. If the actual test were run at RF, a small diode detector (**Figure 7.5**) would be placed in series with the VERTICAL INPUT so that the actual vertical input would be dc. The dc voltage value at any frequency would depend on the filter characteristic.

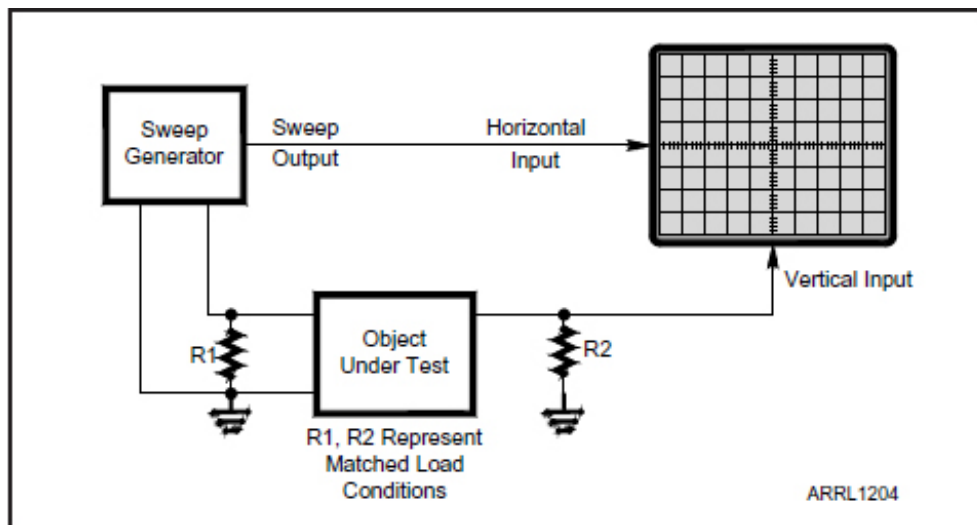

Figure 7.3 — A sweep generator and an oscilloscope can be used to see (and adjust) the passband of a filter, circuit or amplifier (the Object Under Test block).

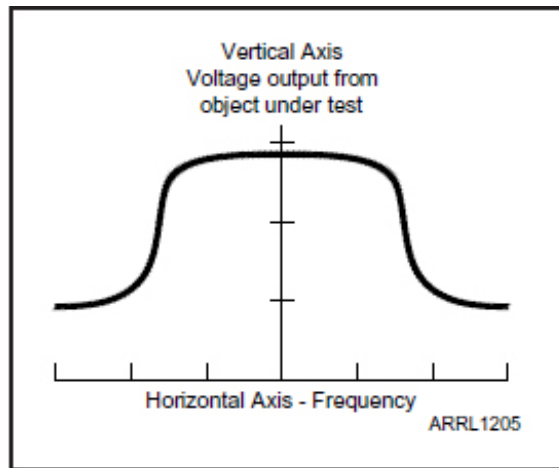

Figure 7.4 — For a band pass circuit or filter under test, the output of the setup in Figure 7.3 would look somewhat like this curve.

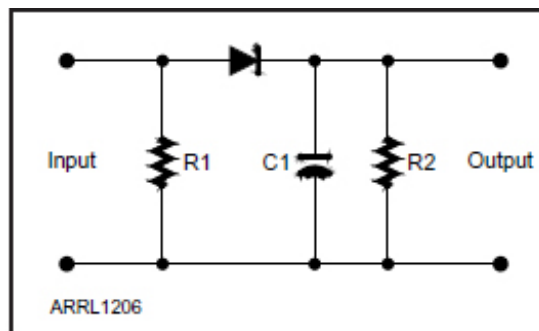

Figure 7.5 — If you need dc from the test setup, a simple rectifier circuit will work. C1 is 0.01 μ F for audio frequencies or 100 pF for RF. R1 and R2 are matching resistors as needed. You may have to make output capacitor C1 larger or smaller depending on the signal.

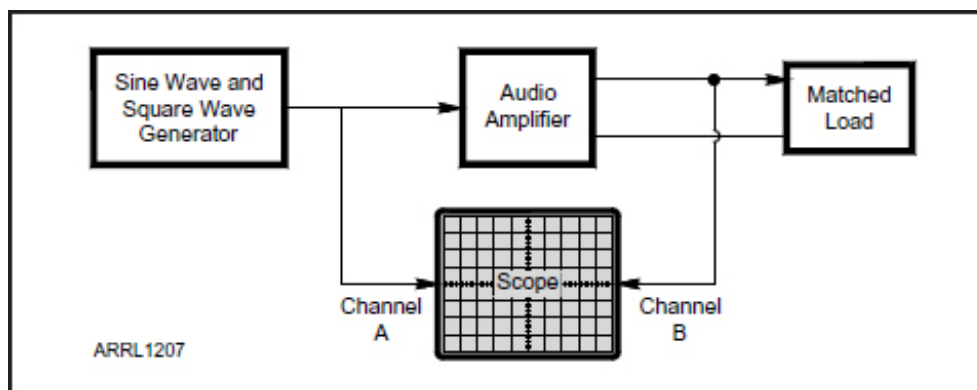

Figure 7.6 — This is the simplest test setup to look for problems with an audio amplifier. Notice that the load must be matched to the amplifier output to give valid results.

Amplifier Linearity

For checking the “goodness” of an audio amplifier, its linearity can be observed by the system shown in Figure 7.6. The input to the amplifier is connected to channel A and the output to channel B. The usual test would use sine wave inputs, but a further, more rigorous test would use a square wave, triangular, or sawtooth input. The sine wave could be at any frequency within the capability of the amplifier, but the square wave frequency should be limited to approximately 1/3 the upper frequency limit of the amplifier.

Although it is customary just to compare the input and output “by eyeball,” a more interesting test is to set the voltage scale on both channels so that they both give the same vertical deflection. Then set the scope to the A–B (A minus B) position. On the screen, if there is no phase delay through the amplifier (an impossibility) the two sine waves would subtract out, but in the practical case, with no distortion, the display would show the phase shift in the amplifier.

Transmitted AM waveform

For many years the classic use of an oscilloscope in the ham shack was to observe (and set) the modulation level of an AM transmitter. Most old *ARRL Handbooks* and reference volumes devoted at least one page to the output RF waveform as seen on a scope under various conditions. As an example, **Figure 7.7A** shows a properly modulated AM transmitter and **Figure 7.7B** shows one with overmodulation.

These pictures still hold for simple, older AM modulated transmitters. Many new ham rigs include an AM capability, with the ability to apply various degrees of speech processing and compression. Often, as seen on an oscilloscope, the transmitted signal will look fine — such as in **Figure 7.7A** — but on the air reports will be very mixed and negative, because it is often very difficult to see the result of processing in this simple scope test.

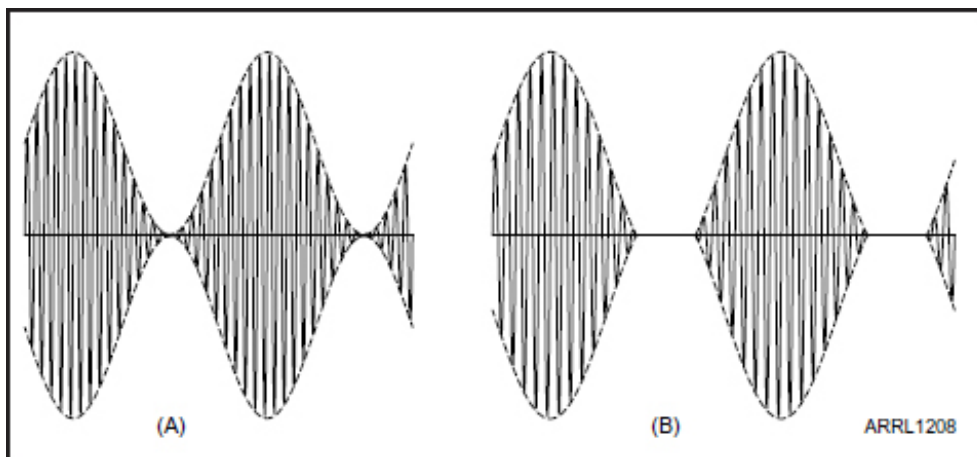

Figure 7.7 — An oscilloscope makes it easy to look for proper AM modulation levels. The modulation envelope in A is correct, while overmodulation is shown in B.

To see the RF output from a transmitter, it is usually not necessary to build a sampling circuit that physically connects to the signal on the transmission line; usually — since the SWR on a coaxial line is rarely 1:1 — you can simply either wind a loop of wire around the antenna feed line in the station or tape a 6 or 12 inch piece of wire along the feed line. Usually there will be sufficient pickup to see the transmitted RF waveform

SSB Testing

Observing a single-sideband signal can also be interesting but misleading. A bit of a voice conversation on 40 meters is captured in **Figure 7.8**. A more meaningful view is **Figure 7.9**, which shows a well-adjusted 75 meter SSB transmitter modulated by a single tone. For comparison, **Figure 7.10** shows what the transmitter output looks like with a single tone but with a carrier that is not fully suppressed. In other words, the transmitter is not putting out a single-sideband signal but a sideband with some carrier.

Again a word of caution — many pictures have been published that show what a good SSB signal should look like. However, just as with an AM transmitter, it is quite possible to have a beautiful picture but get very poor on-the-air quality reports due to maladjustment of the speech processor.

Also see the section on measuring PEP output power later in this chapter.

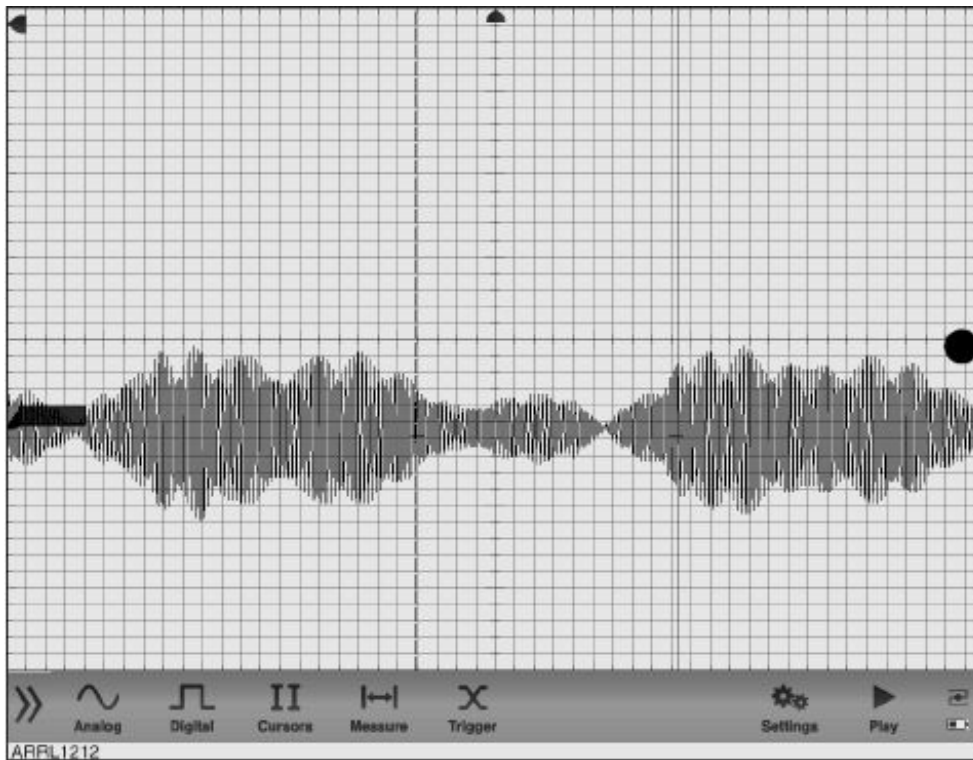

Figure 7.8 — With a properly adjusted SSB transmitter, one or two voice syllables would look like this screen capture.

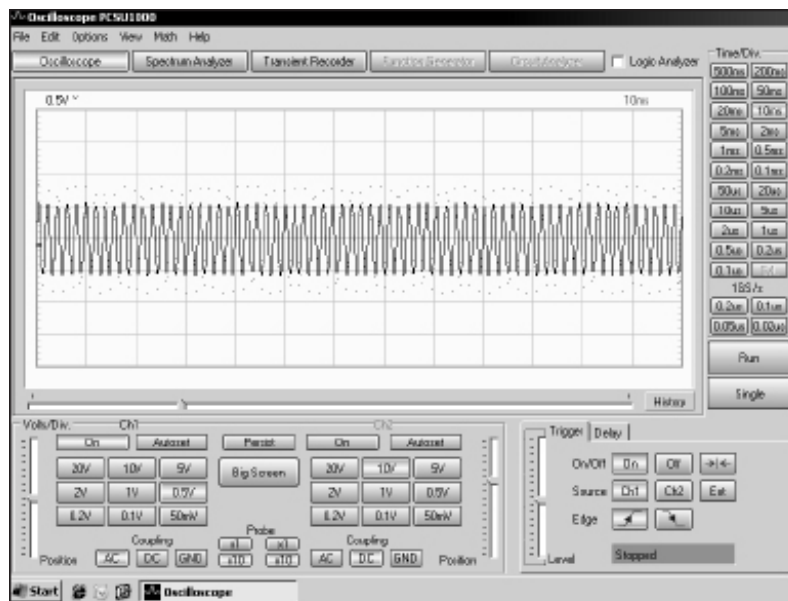

Figure 7.9 — A constant, single tone input to an SSB transmitter produces this uniform picture. If there were noticeable carrier (not enough carrier suppression), the envelope would not be flat.

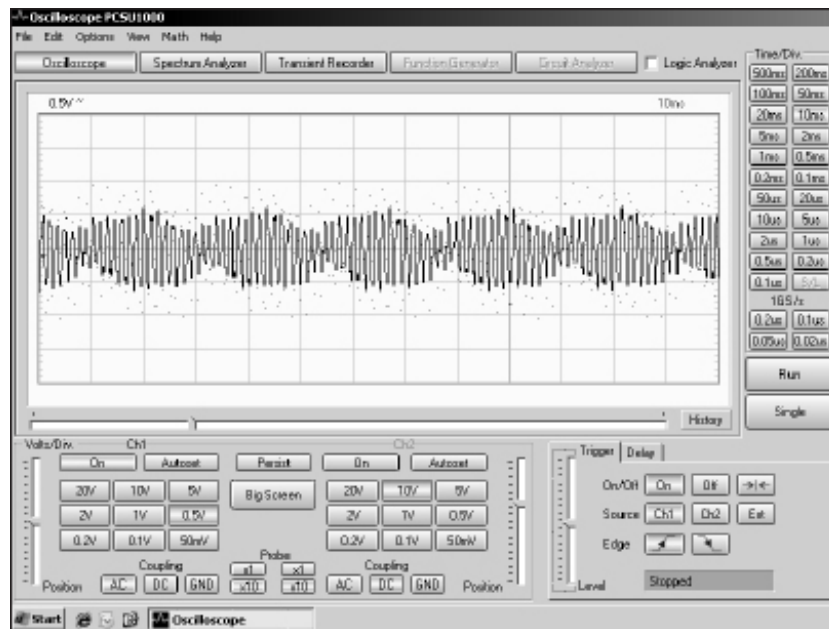

Figure 7.10 — Here, the carrier is not fully suppressed so the viewed waveform looks a bit like an undermodulated AM transmitter.

CW TESTING

There are several measurements that an oscilloscope can make to check the quality of your CW signal. The first, and most basic, is to look at the amplitude of the transmitted dots and dashes. Do they stay constant within the period of a dot or dash? While this seems like a fundamental requirement, did you ever hear someone transmitting a signal that, if an honest report were given, would warrant a tone value (the T in RST, 1 to 9) of less than T9? Older transmitters, especially with poorly regulated power supplies, often suffered from this problem. If the transmitted waveform were examined on a scope while a series of dots or dashes were keyed, you could easily see a change in amplitude during the period of a dot or dash.

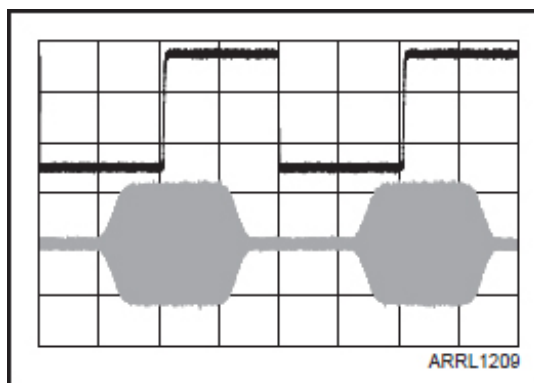

Figure 7.11 — A common scope application is checking the waveform of a transmitted CW signal. Here, the top trace is the key closure and the bottom the transmitted waveform. Notice the gradual rise and fall edges of the bottom trace; this shows a good transmitted waveform.

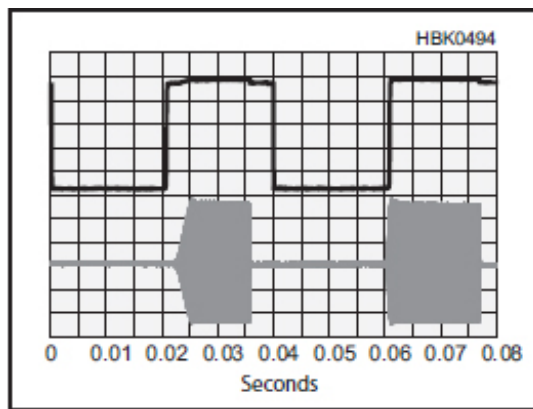

Figure 7.12 — The sharp edges on this transmitted CW waveform will most likely produce key clicks on adjacent frequencies. These waveforms were taken from a series of dots transmitted at 60 WPM. The delay between key closure (top trace) and RF output (bottom trace) is almost a full dot period.

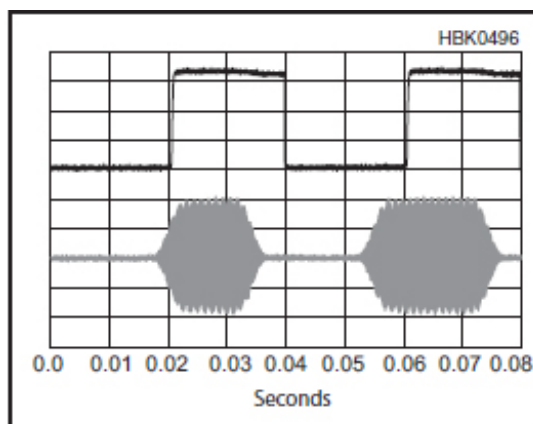

Figure 7.13 — In this CW waveform, notice the shortened first dot, occurring at the start of a transmission. This could be a problem — or not noticed at all!

A good keying waveform is shown in **Figure 7.11**. The top trace is the key closure and the bottom the transmitted waveform. Notice the waveform lags the key closure by a fixed period; this is normal. The waveform has a gradual build-up and decay. Compare this with **Figure 7.12**, where the transmitted waveform has sharp edges which result in a broad signal — in other words key clicks up and down the band.

Figure 7.13 shows another problem that can be seen with an oscilloscope: shortening of the first dot or dash when using break-in. Sometimes this effect is not noticeable and sometimes it has the receiving operator scratching his or her head and asking “What was that first letter?” This effect is particularly noticeable with high-speed CW and fast break-in.

To examine the transmitted waveform closely at the beginning and end of a dot or dash you will want to set up a very fast horizontal scope scan speed. This requires you to use a delayed trigger as explained in Chapter 5. The horizontal scan speed is set to show one or more dots or dashes and the bug, representing the position of the delayed sweep, or the SWEEP DELAY TIME, moved onto the leading or trailing edge of the dot or dash. The time base for the delayed sweep is set to a high speed and the delay sweep turned on. You will then be able to examine the leading or trailing edge of the dot or dash in great detail.

Digital Signals

With the popularity of digital equipment, some oscilloscope manufacturers have added input connections specifically to allow viewing of digital signals, and usually a binary number equivalent number (4, 8, and 16) of them simultaneously. As an example the Oscium scope shown in Figure 2.14 in Chapter 2 has four digital inputs. There may be, depending on the specific scope design, advantages and disadvantages to these inputs.

Certainly having a number of simultaneous inputs (more than two) is an advantage. If the design connects

your signals directly into digital logic elements, without using an A/D (analog-to-digital) converter, higher speed logic circuits may be monitored. However, this direct connection means that the actual waveform is not shown; just logic 1s and 0s are on the screen.

A possible further limitation of a direct digital connection is the allowable input voltage range. While most common digital circuits operate between 0 V (or perhaps minus a few volts, down to -12 V) and up to $+5$ V (or possibly as high as $+20$ V), the allowable input voltage range of direct digital connections are very much restricted as compared to the allowable voltage range using the usual dual-channel, probe connected inputs.

The oscilloscope bandwidth can also provide a misleading but important limitation, when the usual Channel A/Channel B inputs are used. As discussed in Chapter 5, signals such as square waves and repetitive pulses are made up of sums of sine waves. **Figure 7.14A** shows a square wave superimposed on a sine wave of the same frequency. **Figure 7.14B** shows the same square wave, but this time the sine wave is added to a second sine wave that is at three times the frequency. This *third harmonic* sine wave amplitude has been multiplied by a number less than 1.

Figure 7.14C shows the result if the original sine wave, a second one of three times the frequency and a third one of five times the frequency. Finally, **Figure 7.14D** shows the result of adding the original, three times, five times and seven times the original frequency — each harmonic component has a calculated multiplier. Thus as you add more and more odd harmonic sine waves, the result looks more and more like a rectangular square wave.

Now suppose you have a square wave input at, for example, 10 MHz. If your scope bandwidth is only 40 MHz, the third harmonic of the 10 MHz input (30 MHz) will get through, but the fifth harmonic (50 MHz) and seventh harmonic (70 MHz) components will be attenuated. Then the square wave you might see could look more like the one in **Figure 7.14B** — that is the square wave would be rounded at the rise and fall, and not flat at the top and bottom.

Fortunately the situation is not totally like this, because a scope's bandwidth does not fall off a cliff. A 45 MHz bandwidth means the response to a 45 MHz sine wave would be about 3 dB down in voltage, so some of the 5th harmonic energy would get through.

The net result is this: While a scope bandwidth specification tells you just how high in input signal frequency you can go suffering only a 3 dB loss, the same bandwidth is a limitation of the fidelity of the digital signals; they may not be seen with their proper waveshape! This phenomenon is discussed further in Chapter 8, where specifications for a scope's vertical channel rise and fall time are noted.

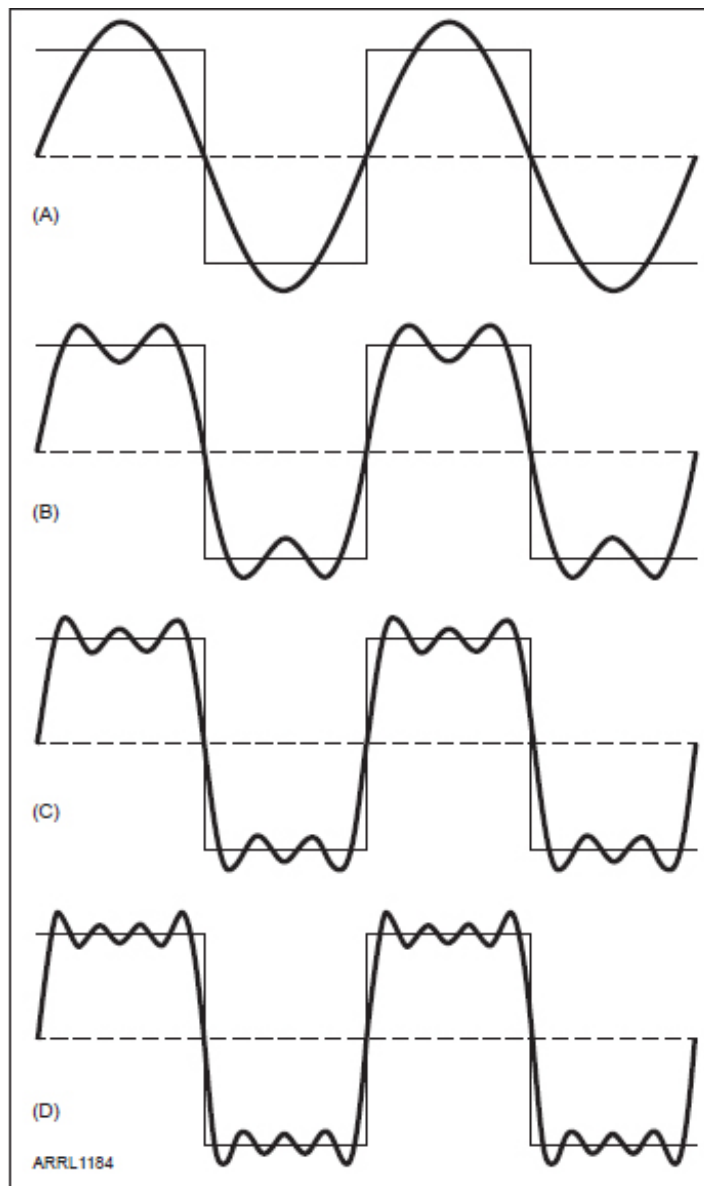

Figure 7.14 — A square wave is the sum of odd multiples of the square wave frequency. To be perfectly rectangular, it would be made up of the sum of an infinite number of sine waves.

Another consideration that can be a great advantage when viewing digital signals is the ability to see one-time action. Sometimes, for unanticipated reasons, something will happen very quickly, and your eye will not catch it. Here the ability to set an oscilloscope into a *storage* mode, where the trace is triggered just once and the result left on the screen, can be invaluable. Again, as pointed out before, digital storage scopes retain the input data in memory, so that the ability to store one or more traces is built-in for examination at leisure.

RF Detection

As mentioned in the preceding section, oscilloscope bandwidth is not a cliff. A bandwidth specification such as 50 MHz does not mean that you will see no signal above this frequency. It does mean that this is the frequency, commonly noted as *3 dB down*, above which waveforms will not be seen with their true amplitude. It is not unusual to be able to see signals at twice or three times the rated bandwidth, but the amplitude will likely not be accurate above the rated frequency.

If you are trying to do this, remember to check the probe setting and perhaps place it in the X1 position instead of X10. A second important point, especially with RF at any time, is that you may not know the actual voltage of an RF signal. Some caution is required so the oscilloscope or the probe is not damaged by overvoltage.

As noted previously, to pick up RF from a transmission line often it is not necessary to connect to the transmission line. A loop of several turns around a coaxial line, especially where the SWR is not close to 1:1, may be sufficient. A 6 or 12 inch piece of wire taped to the transmission line may also work.

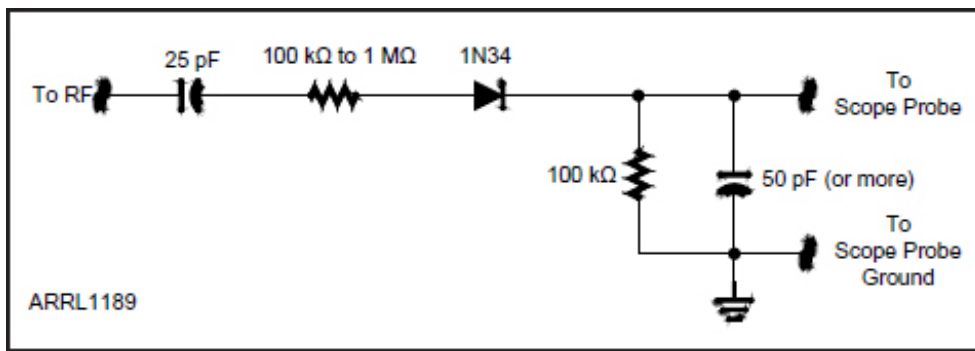

Figure 7.15 — This RF detector will produce a rectified envelope of your transmitted signal.

When you want to see the modulation envelope of an RF signal, a simple diode detector connected to the RF pickup device will suffice. **Figure 7.15** shows one such circuit. You may have to increase or decrease the value of the 50 pF output capacitor, depending on the bandwidth of the modulation. A germanium diode, the venerable 1N34 is shown. A germanium diode here has the advantage of more sensitivity since the voltage drop across it is less than a silicon diode.

Time (Frequency) Measurements

In the normal use, the horizontal axis of an oscilloscope is set so the trace moves from left to right at the set *time base* rate — but as you can see from the title of this section this time base or scan rate represents both time and frequency. For any periodic wave, the relationship is $f = 1/T$, where f is frequency and T is time. As an example, a 1000 Hz sine wave — that is, 1000 alternations per second — traces out 1000 sine waves per second. The duration or period of a single sine wave is $1/1000$ of a second. To see the waveform of interest, you have to set the time base so the waveform is visible. Fortunately you don't have to know the waveform frequency accurately; you can put the waveform on the screen and vary the time base until you get a satisfactory picture.

Using the Time Base

All oscilloscopes have a TIME BASE control, which is calibrated in units of time per division. For example, in **Figure 7.16** the TIME BASE control (which is labeled TIME/DIV) is set to 0.5 ms (one half millisecond) per division. Therefore, if the graticule on the screen has 10 major divisions across, it takes 10 times 0.5 ms to sweep across the screen, or 5 ms.

As another example, a 400 Hz sine wave has a period of ($T = 1/f$) or ($T = 1/400$). Therefore one complete sine wave takes $1/400$ of a second or 2.5 ms. Since the horizontal scan rate or time base is set to 5 ms for a complete scan across, $5/2.5 = 2$, so there will be two complete sine waves showing.



Figure 7.16 — The sweep rate or time base control is labeled here as **TIME/DIV**. Notice the variable control (**VAR SWEEP**) to its upper left.

However, just as with setting the vertical channel sensitivity, it is very easy to make a mistake here. Look just to the upper left of the TIME/DIV control in the figure. There is a variable sweep control on this oscilloscope, and unless it is turned fully clockwise to the CALIBRATE position the time base will not reflect the main control setting. In addition, some oscilloscopes have an X5 (5 times) multiplier switch. Having this switch in the ON position also will make any direct reading of the TIME/DIV control wrong by a factor of 5.

As will be discussed in Chapter 8, the accuracy of the time base may be from 5% to 10% for older analog scopes and within a few percent for newer digital scopes. If more accuracy is needed, an external time base or *marker generator* can be used. There are generally two ways the generator can give you a better time base reading. The first is to put the waveform you are measuring into one channel and the time generator into a second, superimpose them and do your measurement.

The second way to is to use the VARIABLE SWEEP control mentioned before. Put the marker generator into one channel and use the VARIABLE SWEEP control to make the marker pulses line up with the divisions of the graticule on the screen. Now you can count the divisions directly, because they have been calibrated by the marker generator.

Lissajous Patterns

An older way to use a scope to measure frequency uses a known, calibrated sine wave generator. As seen in **Figure 7.17**, the known frequency source is connected to either the vertical input or the horizontal input and the unknown into the other input. When the known generator is set to an exact multiple of the unknown frequency, one of the patterns shown in the figure results. The number of lobes is equal to the frequency ratio. This technique dates back to before inexpensive digital frequency counters were available, but is cost free and is an additional use for your scope.

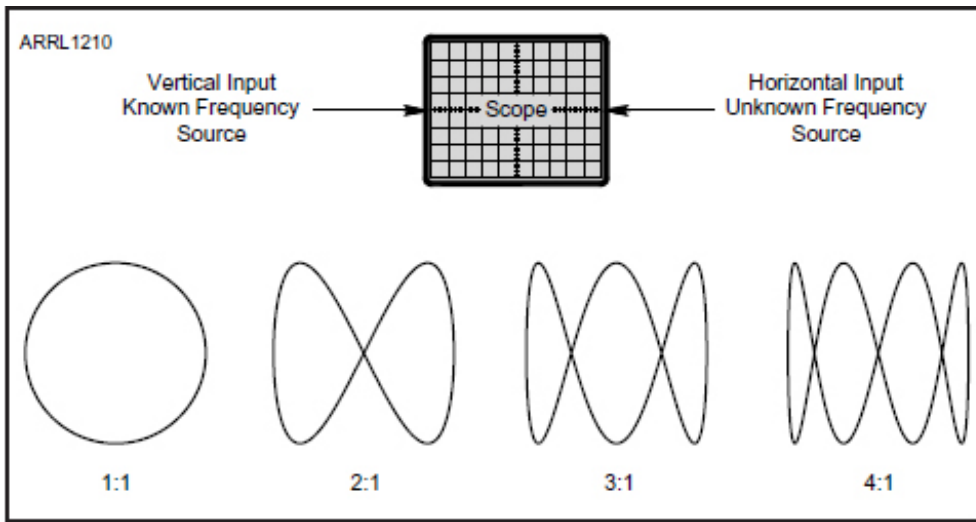

Figure 7.17 — These Lissajous patterns show a frequency ratio of 1, 2, 3 and 4 to 1. With a calibrated signal generator, they can be used to measure frequency of an unknown sine wave.

Gadgets to Add

There are any number of small (and not-so-small) circuits you can build to extend the use of your oscilloscope. Some are very quick to build and use — for example, if you have a sine wave generator with a known frequency calibration, just add a resistor in series with an unknown capacitor or inductor and you can measure the voltage across the unknown component and then calculate its value.

Diode Tester

A very popular accessory is shown in **Figure 7.18**. It is a diode tester, and when the diode is operating properly the pattern of **Figure 7.19** results. Notice the approximately 0.6 V flat horizontal line on the display. This was a silicon diode under test; it takes approximately 0.6 V forward bias before it conducts. The same circuit can be used to check the base-emitter and base-collector junctions of transistors and several other types of diodes.

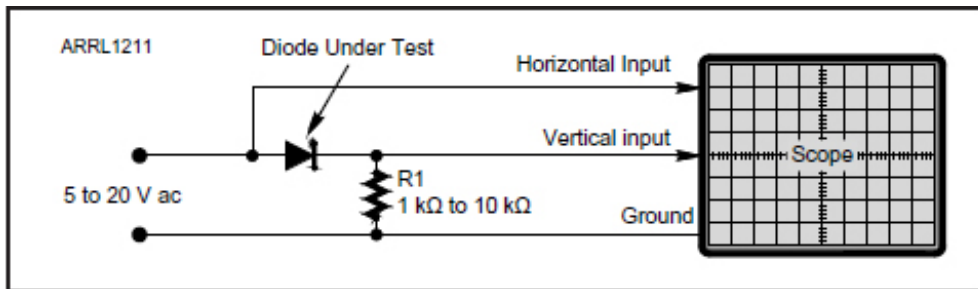

Figure 7.18 — Is the diode blown open or shorted out? This simple circuit, attached to your oscilloscope, will answer that question.

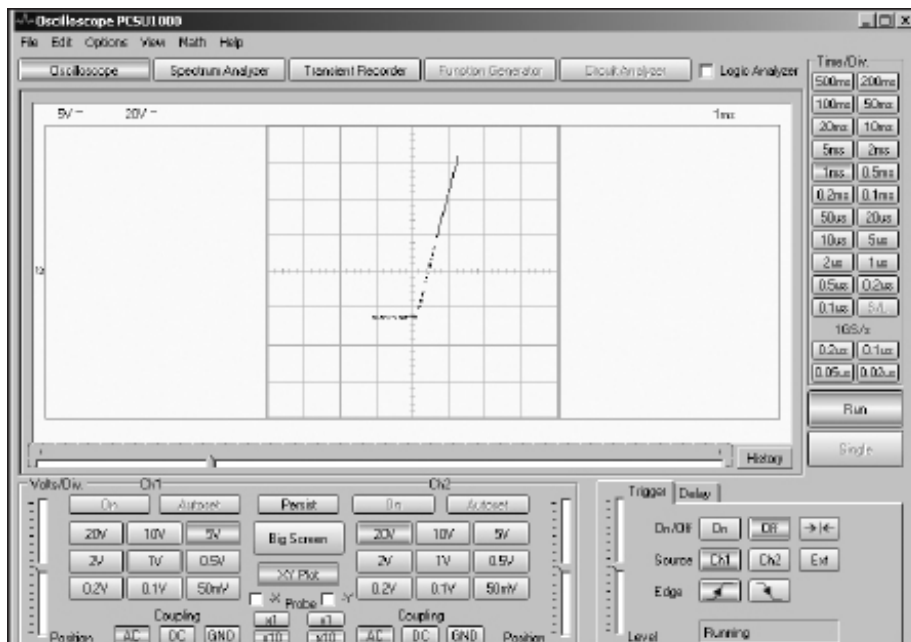

Figure 7.19 — A good diode produces this pattern in the circuit of Figure 7.18.

High Frequency Ammeter

An oscilloscope can be very useful as an ammeter. At frequencies above 60 Hz power line ac, ammeter performance falls off in a generally unknown manner. Chapter 6 included a discussion of using a dual channel scope in a differential mode. By placing a very small resistance in series with the line carrying the current, and placing the two probes at opposite ends of the resistor, Ohm's Law will give you the current as the voltage difference divided by the resistance. The frequency limit here is the scope performance, which is obviously a lot higher than 60 Hz!

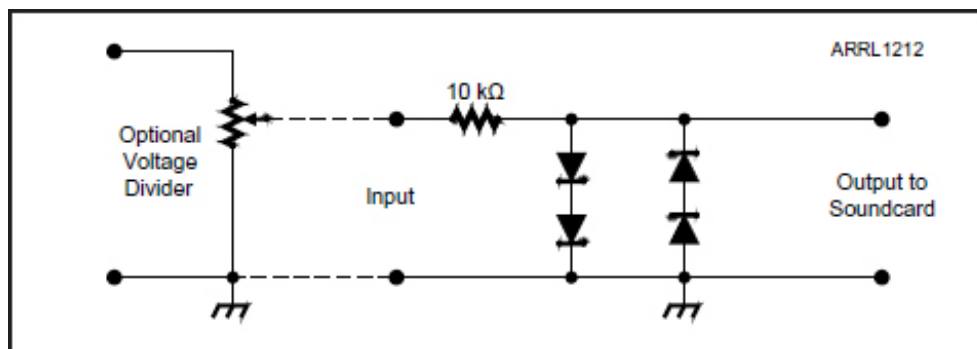

Figure 7.20 — It is best to protect your sound card if you want to try out one of the many no-hardware oscilloscopes, downloaded from the Internet.

Sound Card Protection

Chapter 8 includes a brief discussion of an interesting no-hardware oscilloscope that uses your PC and the capabilities of the sound card. Specifically, a version of oscilloscope software is hosted on the PC. The input is not through an analog vertical amplifier and external A/D, but through the A/Ds found on the computer's sound card.

Obviously the performance of this type of scope is limited to the bandwidth of a typical sound card, perhaps 20 – 20,000 Hz. Exposing your sound card to an outside signal can result in the loss of the card. A basic protection circuit for this scope is in **Figure 7.20**. Using two silicon diodes in series limits the voltage into the sound card to about 1.2 V, positive or negative. An optional voltage divider (a single variable resistor) is shown to adjust the input level. In addition to the bandwidth limitation, this type of system does not have a high input impedance and can easily load down the circuit under test. For an audio frequency scope to compare amplifier input and output signals (in other words, look for distortion), the price is right.

Scope Bandwidth Extender

If you have an oscilloscope with, for example, a bandwidth of 10 MHz and would like to examine a 28 MHz signal, you might be able to do it. If you could convert the 28 MHz signal down to a frequency below 10 MHz, that would be ideal. This solution is not much different than the approach used in many receivers — heterodyning the signal down to a lower frequency. One such circuit is shown in **Figure 7.21** (reproduced from Chapter 25 of the 2010 *ARRL Handbook*). This circuit uses three transistors and a single MiniCircuits SRA-1 mixer.

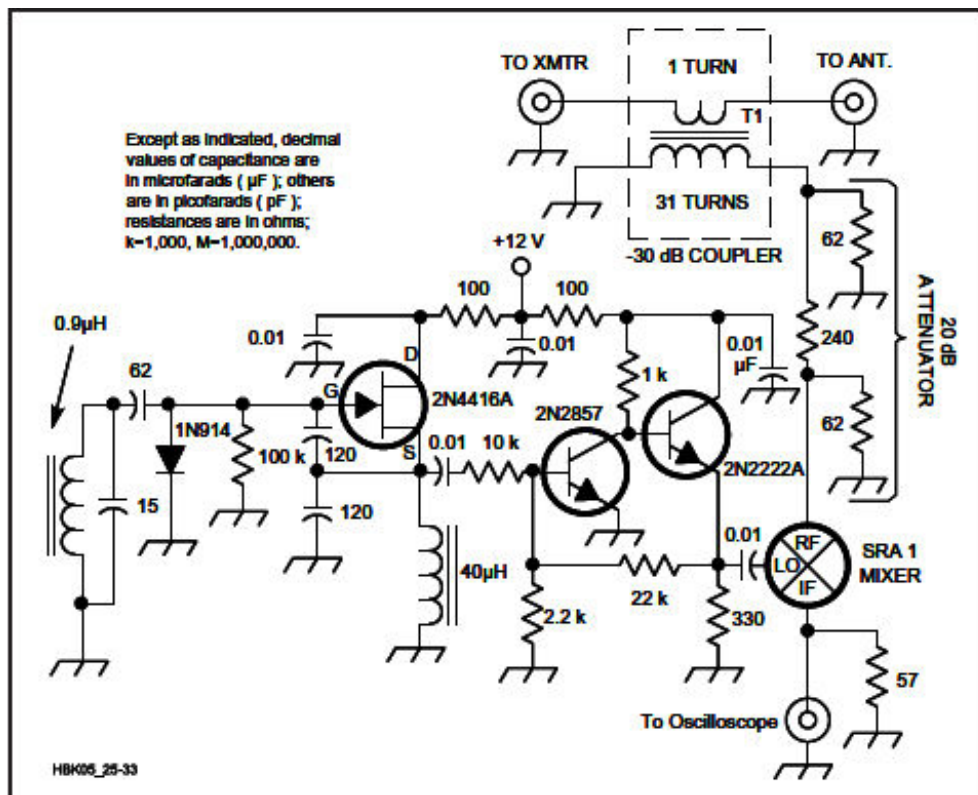

Figure 7.21 — This adapter displays HF signals on a narrow-bandwidth oscilloscope. It uses a 10-dBm 25-MHz local oscillator, -30 dB coupler, 20 dB attenuator and diode-ring mixer.

Although this project may be more than you want to undertake, it does serve to remind you that you can take an old receiver, making sure not to overload it with too high an input signal, and tune it to whatever signal you want to examine. Connect your oscilloscope to the IF amplifier and you will get to view the higher frequency signal. Remember, however, that the signal you see is now limited by the receiver bandwidth and not the scope bandwidth.

Measure Your PEP Output

One of the most perplexing questions many hams ask, after they think about the FCC requirement of “no more than 1500 watts PEP,” is “How can I measure it?” Just how much PEP (peak envelope power) is my transmitter putting out? Even though you may be using one of the many 100 watt output transceivers (per the manufacturer’s specification) so common on the bands, just how much power is coming out?

You can use a scope to get a fair measurement of this number, using the calculation technique in Chapter 2 of *The ARRL Handbook* and described here, but you will have to exercise caution so that you don’t damage yourself, your scope or its probe. With higher power transmitters you could be exposed to RF voltages in the 600 to 1000 V range.

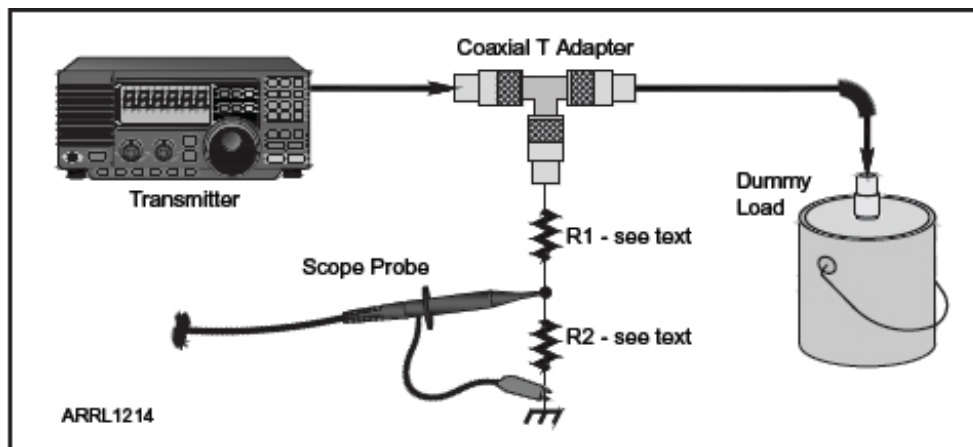

Figure 7.22 — You can build a simple test fixture with a coaxial T adapter and a resistive divider to measure peak envelope power (PEP) with an oscilloscope.

First connect your transmitter to 50 Ω dummy load through a coax T adapter. The load has to be resistive, with no inductance or capacitance.

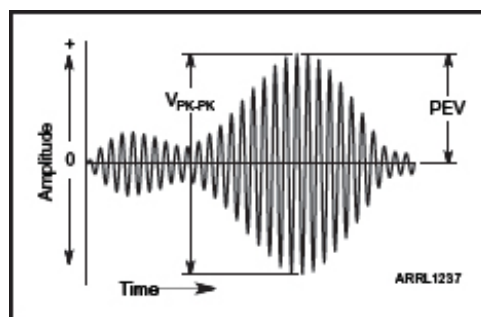

Figure 7.23 — The peak-to-peak voltage and peak envelope voltage (PEV) as seen on an oscilloscope screen.

Your scope probe is probably limited to a few 10s of volts, so next you will have to build a voltage divider with a ratio of perhaps 50 to 1 (see **Figure 7.22**). For example, you could use a 49 k Ω resistor (R1) and a 1 k Ω resistor (R2). The exact values are not important, just as long as you know the divider ratio.

$$\text{Divider Ratio} = R2/(R1 + R2) = 1000/(49,000 + 1000) = 0.02$$

$$1/0.02 = 50$$

This is not the place for 1/4 W resistors, unless you like to see RF arcing! Physically large, non-inductive resistors are needed, perhaps of the 2 W variety or physically larger. The resistor power rating is not critical. When you connect the free end of the larger resistor to the remaining center port of the T adapter, do it such a way that neither your hand nor anything else will come in contact with the high RF voltage this point. The scope probe is connected to the junction of the two resistors and the probe return is connected to ground.

Now you can turn on your transmitter on, talk into the microphone, and measure the highest peak-to-peak voltage seen on your scope — for example, you see 4 V peak-to-peak on your scope.

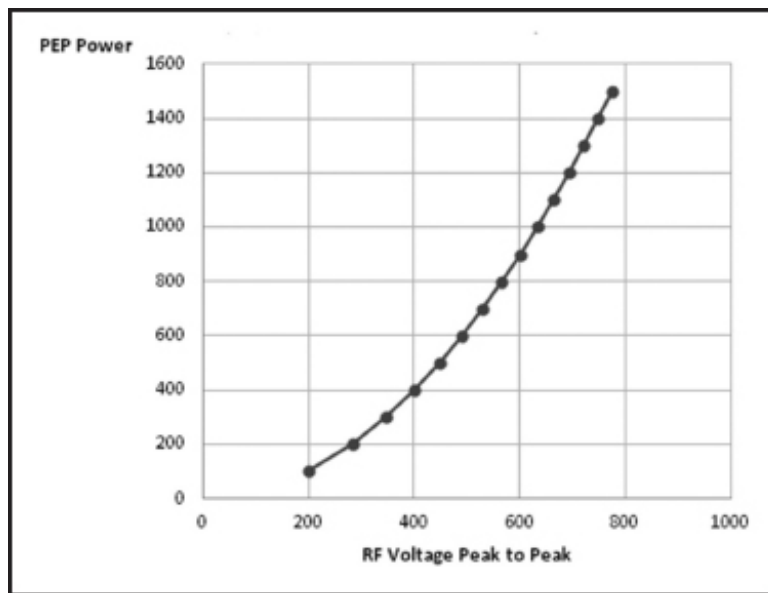

Figure 7.24 — Measured RF voltage versus peak envelope power.

Take that measured voltage and multiply it by the voltage divider ratio to get the actual voltage at the T adapter. In this example, $4 \text{ V} \times 50 = 200 \text{ V}$.

This is now your “true” transmitted peak-to-peak voltage. Divide by 2. You now have your transmitted peak voltage (peak envelope voltage, or PEV, as shown in **Figure 7.23**). In this example,

$$\text{PEV} = 200 \text{ V} / 2 = 100 \text{ V}$$

You are almost there. Following the *Handbook* method, multiply this peak value by 0.707 to get the RMS voltage (V_{RMS}). In this example,

$$V_{\text{RMS}} = 100 \text{ V} \times 0.707 = 70.7 \text{ V}.$$

Then, with a 50Ω load, your $\text{PEP} = V_{\text{RMS}}^2/50$. In this example, $\text{PEP} = 70.7^2/50 = 100 \text{ W}$.

Figure 7.24 is a plot of PEP versus measured peak-to-peak voltage into a 50Ω load.

Other Oscilloscope Capabilities

Because newer oscilloscopes contain a microprocessor, memory, input/ output connections, program controllers and stored programs, they meet the definition of a computer. It’s no surprise that this same hardware with additional programming can be used to supply other math and test functions.

For example, to measure the peak-to-peak value of a waveform, the program just looks for the maximum stored value of the input and the minimum stored value, subtracts, and that is the peak-to-peak value. To measure periods and therefore frequency, it looks either for zero crossings or points of similar inflection (goes from positive slope to negative slope or vice-versa).

The following list is a summary of the functions supported by modern oscilloscopes. Of course, these extra features are available for a price—you are paying for the capability and software rather than extra hardware.

- Digital bus monitor/analyzer
- Digital pattern generator (multichannel)
- Logic analyzer (multichannel)
- Math functions: FFT (fast Fourier transforms), derivatives, integrals, statistics, frequency analysis
- Network analyzer
- Power supplies: $\pm 5 \text{ V}$ and/or $\pm 12 \text{ V}$
- Signal generators
- Spectrum analyzer
- Voltmeter

This is, of course, only a partial list just to illustrate the computing power available in modern oscilloscopes.

Chapter 8

If You Are Going to Buy One — Specifications

The previous chapters have discussed oscilloscope characteristics and applications. You're thinking that a scope might be a useful addition to your workshop. How do you choose?

What Are You Going to Use It For?

This is the same question many of us have faced when planning to buy a new personal computer. There are a wide variety of oscilloscopes (and personal computers!) available, with a wide variety of capabilities. But as usual, the first question is not “What scope?” but “What use?”

Prices of new units range from \$150 or \$200 and up — very up. Used scopes can be had for as little as \$25 at flea markets. There are many 1950s, 1960s and 1970s units still being sold and traded. But they often have only one input channel, may not use high impedance probes (and therefore can load down a circuit) and are primarily vacuum tube designs.

You can also find 1980s and later laboratory-quality scopes for \$100 or more with capabilities we could only dream of years ago. There are, however several problems with these types of used scopes.

For scopes that use vacuum tubes — where do you get them and at what price? Not only do you have to plan to replace tubes from time to time (if not immediately when you buy the unit) but these older designs need periodic calibration, especially when you replace tubes. The lab-quality units were built to be as accurate and stable as possible, but you can get a clue from finding a sticker on the case from the original owner. This sticker often says “Calibration Due _____” with a hand written date. If they are not recalibrated — and calibration is not always an easy task without accurate standards equipment — you cannot be sure just how good your measurements are.

The other problem with the used equipment is heat. Although the 1950s units were designed for TV repair shops and before universal air conditioning, the lab-quality used equipment was primarily intended for air conditioned, low humidity environments. Putting one of them in a damp basement workshop may not work out very well.

There are three general types of oscilloscopes you can consider to meet your needs. The first is a *completely self-contained* unit. It may be analog or digital, with the analog units tending toward the lower end of the price and performance ranges. Today's scopes are nowhere near as large and heavy as those of past generations, but they can take up measurable bench room.

The second type is a *digital pluggable unit* mating with a laptop or personal computer. They are relatively small, usually have no panel controls and accept commands by way of the PC mouse and keyboard. They are very portable, and can be plugged into almost any personal computer or laptop — but first their matching software must be installed in the PC, usually from a CD.

The third type, *ultra-minis*, plug into tablets, smart phones and other hand-held digital devices. Their software is hosted in the digital device and must be downloaded from the Internet. Generally they have a large number of available functions, but their performance specifications (such as bandwidth) are very minimal.

There is a fourth type, *software only* scopes, that have limited capabilities at audio frequencies. These are discussed later in this chapter.

Don't Overbuy

Yes, it would be very nice to own a modern digital storage scope with a bandwidth of 500 MHz and a high-precision spectrum analyzer built in. But how often are you going to use the maximum capabilities? As

pointed out before, to see a 6 meter (50 MHz) signal, a 30 MHz scope may be good enough — the amplitude of the displayed waveform will be lower than the actual value, but you can probably see the signal. It is nice to have an input sensitivity of 3 μV , but often ambient noise will be greater than that so your measurements in this range will be highly questionable. Why pay for this capability?

The control section of a recent model analog oscilloscope is pictured in **Figure 8.1**. By contrast, **Figure 8.2** shows some of the controls on a digital scope. Many of the functions are selected by push button or rotary control of menu items displayed on the screen.

Modern digital scopes often use their digital memory and computing power to give you a host of extra functions. But some of these functions may not be available simultaneously when the unit is used as a scope. What is the point of using the signal generator function as the input to an amplifier when you want to look at the output, but the scope function is not available when using the signal generator function?

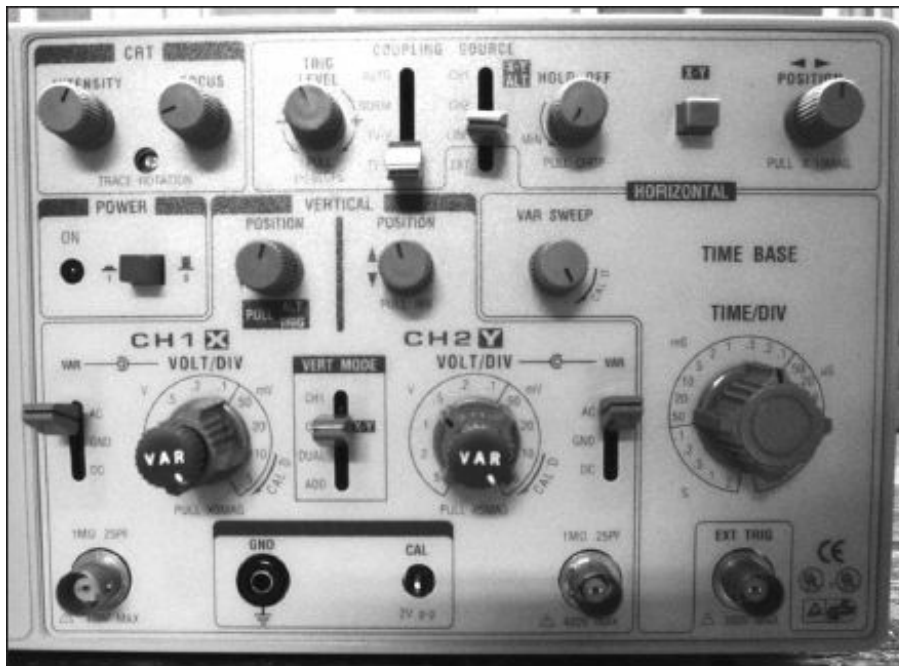

Figure 8.1 — Typical dual-channel analog scope control panel. Notice the functional partitioning — Vertical, Horizontal and Trigger (Coupling). Power and display controls are grouped in the upper left-hand corner.

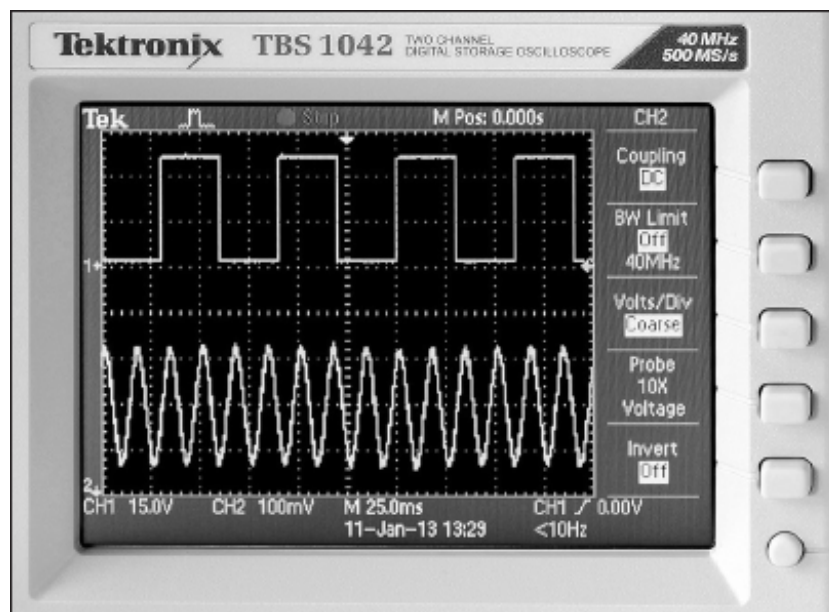

Figure 8.2 — For modern digital storage scopes, the controls are often a combination of front panel controls and on-screen menus.

The following sections will first look at scope specifications in general, then some of the special features of a digital scope. You may find that not all of the specifications you want to know are listed on a manufacturer's

website or data sheet.

Specifications Common to Analog and Digital Scopes

Basic Capabilities of the Vertical Channels

Unless you are looking to buy an antique oscilloscope (from the 1950s to 1970s), there are certain basic capabilities and features found on just about all oscilloscopes. These include:

- *Dual channel inputs.* All scopes now have two analog channels.
- *Ac and dc coupling plus ground.* Selecting the ac coupling (input) position allow you to see an ac waveform independent of any dc voltage it may be riding on. This is very handy when you have a small ripple voltage you want to look at, but it is on top of a 50 V dc line. If you select the dc position, you would have to set the vertical scale to allow a 50 V signal to be seen — thus the small ripple will be almost invisible. Select ac coupling and now you can pick a good scale to see the ripple. The Ground position gives you a reference level to set the vertical position of the sweep. Discussion of dc measurements from this point on will be with respect to the selected Ground position.
- *Vertical channel accuracy.* This is a number, usually expressed as a percentage, supplied by the manufacturer. There is one important difference here between an analog and a digital oscilloscope. An analog scope must keep circuit accuracy and stability from the input through an entire circuit chain up to the display. A digital scope only has the analog accuracy problem through its input stages. From there on, the accuracy depends primarily on the input A/D (analog to digital) converter. A/D converter accuracy is discussed later in this chapter. As you might surmise, the analog scope may require periodic calibration of the vertical channels whereas the digital scope rarely requires it.
- *Selection of either channel alone, both (alternate) and both (chopped).* The chopped mode, where a small piece of each channel is sampled and displayed alternately, is frequency dependent. For example, if the chop frequency is 500 kHz, this means that a piece of each input waveform is shown approximately every 2 μ s. If you are looking at a waveform with information that could appear within a 2 μ s period on channel A, it may or may not show up if the chop selection is on channel B during its occurrence.
- *Algebraic combinations (A plus B, A minus B, and so on).* Some scopes will offer A+B and an *invert* function on B. By switching probes, all four algebraic combinations are then possible.
- *High input impedance inputs.* Generally 1 M Ω and 10 to 25 pF are the normal values without probes.
- *Fixed and variable input scales (sensitivity).* The ability to measure down to a few tenths of a millivolt sounds like a good idea, but in practice system noise and general pick-up limits its usefulness. The upper range is important, since applying overvoltage can have a simple effect — if the input maximum rating is 150 V and you apply 500 V, you can easily burn out the vertical amplifier. The result, simply stated, is a dead scope. Normally, the maximum input voltage rating is limited by the probe used. When the variable sensitivity control is in the CALIBRATE position, the number on the selection scale gives you the voltage value per major graticule division. Thus if you select 0.5 V, this means a 0.5 V peak-to-peak sine wave will be exactly one graticule division (usually measured in centimeters) high.
- *Probes supplied.* Most commercial scopes, purchased new, come with a set of simple probes that can be set to either X1 (straight voltage measurement) or X10 (attenuates the input voltage by a factor of 10).
- *Frequency response (bandwidth).* This is the number that most hams focus on. It is important, but not the only important number. As mentioned in earlier chapters, the bandwidth number means this is the frequency where an input sine wave will be displayed 3 dB lower than its actual value. At the upper limit of the bandwidth specification, a 10 V sine wave will be displayed as 7.07 V.

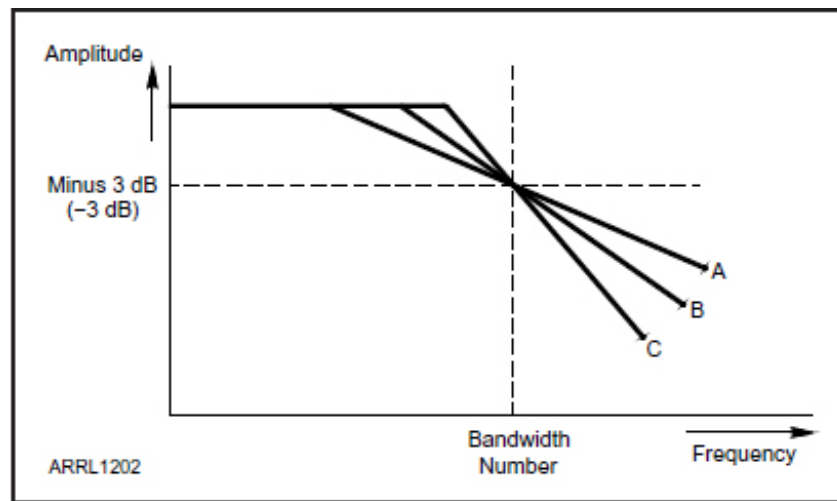

Figure 8.3 — Idealized vertical channel response, corresponding to the specified bandwidth. All three curves meet the specified bandwidth number, but with differing characteristics.

The bandwidth specification can be very misleading when you want to know the scope performance at frequencies higher (and lower) than the specified bandwidth number. In **Figure 8.3** the horizontal line represents constant gain. Line *a* shows the gain falling off at a frequency much lower than the bandwidth frequency, but it has higher gain than the others beyond the bandwidth frequency.

Line *c* is the other extreme. It shows the gain falling off much closer to the bandwidth frequency, but shows lower gain past the bandwidth frequency. You can see that all three designs meet the bandwidth specification, but if you are looking for performance beyond the bandwidth point, there can be big differences among scope models. In practice the sloping line would not be as straight as shown but rather a smooth curve.

■ *Frequency response (rise and fall times)*. No, this is not an accidental duplication of the frequency response paragraphs above. If you are looking at a digital pulse — assuming it has perfect vertical rise and fall times — the bandwidth also limits how well the “perfect” pulse will be displayed. The generally accepted formula — an approximation — is

$$t(\text{rise}) = 0.35/\text{bandwidth (in MHz)}$$

Thus, as seen in **Figure 8.4**, a perfect square wave rise time will be seen as a 35 ns rise time on a scope with a 10 MHz bandwidth. Although “rise time” has been used in this explanation, the same ideas and formulas hold for fall times.

Since perfect square waves, with perfect rise and fall times do not exist, a real question is what exactly are you seeing? The answer is given by this formula:

$$t(\text{seen}) = \sqrt{t(\text{rise})^2 + p(\text{actual})^2}$$

where $t(\text{rise})$ is the scope rise time number from the preceding paragraph and $p(\text{actual})$ is the actual pulse rise time.

If you want to visualize it, the answer is rather like the value of the hypotenuse of a right-angle triangle, where the scope rise time and the pulse rise time are the two orthogonal sides.

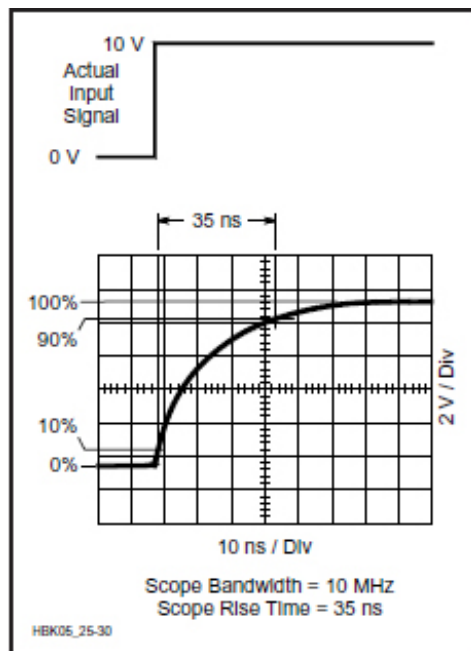

Figure 8.4 — Using the formula in the text, the rise time for a 10 MHz bandwidth is 35 ns from the 10% point to the 90% point.

Basic Capabilities of the Horizontal Channel

■ *Horizontal sweep selection.* This control is usually marked in units of time (microseconds, milliseconds and seconds) As an example, selection 1 μs translates into a sweep rate of 1 μs per horizontal graticule marking. With the usual 1 mark per centimeter, it would take 10 μs to sweep across the screen. A 2 MHz sine wave (a complete period equals 5 μs) would be seen as two complete sine waves across, assuming the first one started at the left edge of the screen.

■ *Sweep magnifier.* Many scopes have a sweep magnifier control, either 5X or 10X. When selected, the sweep rate chosen is divided by this number — the magnifier expands the display by the 5 or 10 factor.

■ *Direct horizontal input.* This is, perhaps, a rarely used feature (see the section of Chapter 7 on Lissajous figures). However, it does come in handy from time to time. Unfortunately the sensitivity control for direct input (volts per cm) is often hidden — sometimes it is piggybacked on the horizontal sweep setting control — but unmarked!

■ *Accuracy and stability.* Since the horizontal sweep is used to measure time or frequency, its accuracy and stability are critical. Analog scopes, using purely analog circuits, usually have much poorer specifications than digital scopes. Not only do the analog circuits making up the sweep have to be designed to be accurate, but they also have to be stable with temperature and time. Digital scopes usually use a crystal-controlled clock and thus are less prone to circuit drift. While analog sweep circuits may require periodic calibration, digital scopes rarely if ever require this sort of alignment.

■ *Delayed sweep.* There are several names and techniques for displaying a section of a waveform that occurs later than the point where the horizontal sweep is triggered. You can see such terms as *Delay Time Position*, *Holdoff* and *Segment Magnification*. This function was described in an earlier chapter, but in summary these functions allow you to pick the point you want to examine and expand the sweep around the selected point without changing the trigger point. You would use this feature if, for example, your scope is set to display a 10 ms segment of waveform across the screen, and you want to examine closely a point on the waveform that occurs 2 ms from the start of the sweep. You can examine any selected part of the entire 10 ms long waveform in a small selected area with a sweep rate of 1 $\mu\text{s}/\text{cm}$ in this selected area.

Basic Capabilities of the Trigger Section

While many people focus on the bandwidth specification, the triggering features are of equal importance. If you do not have a stable sweep, started by a trigger, you cannot see whatever you want to look at. When it comes using an oscilloscope, setting the trigger is the one thing that gives many people a problem. Not all of the selections listed following will be found on every scope, but they are capabilities you should consider.

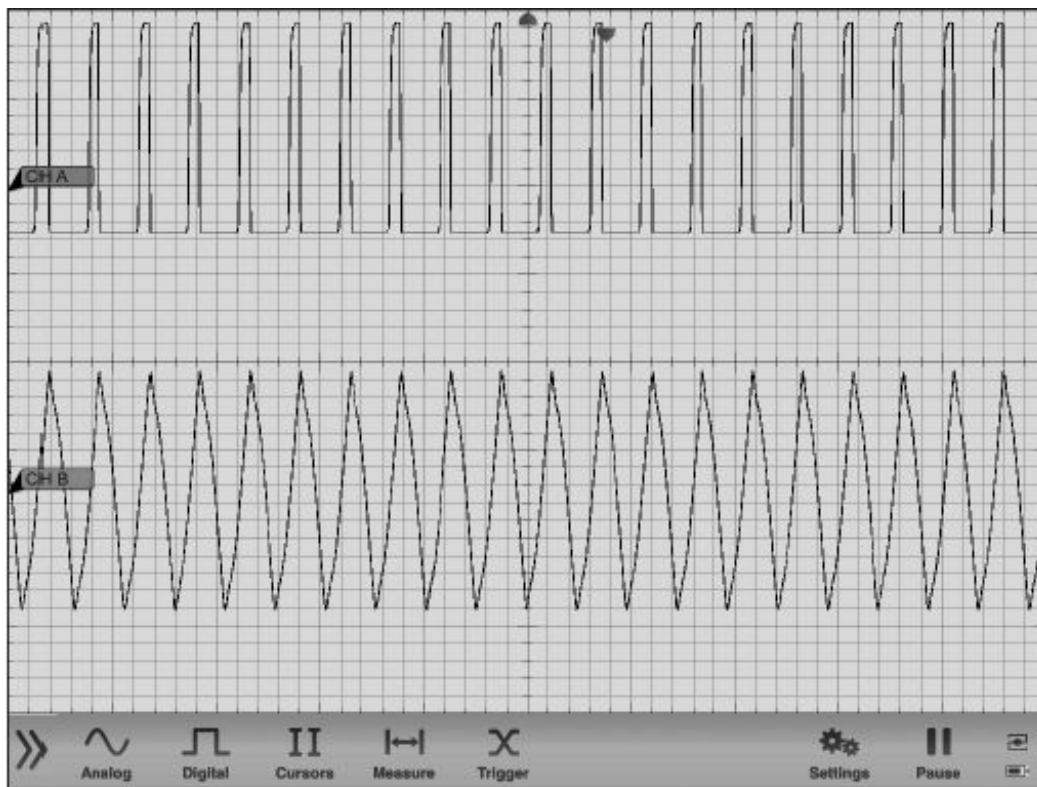

Figure 8.8 — Scope performance is dependent on the memory and processing power of the host device (a tablet or smartphone), but as the screen shot shows it is a fully functional and capable oscilloscope.

- *Convenience.* Many new scopes offer convenient features, such as automatic setup. Connect a waveform, and the scope sets the vertical voltage scale, horizontal sweep rate and trigger settings to numbers it measures as applicable. Then you can tweak these setting any way want. How about one-button measurements? Select from a menu to get readout of peak-to-peak voltage, maximum voltages, average voltage, frequency, periods and other measurements. Is there a cost? Of course, but if you are making repetitive measurements it might well be worth it.

- *Waveform storage.* In an earlier chapter it was noted that digital scopes store the input data, and thus can provide a stored picture. One number that can be specified is how big this picture can be; that is how many seconds or milliseconds of data can be stored.

- *Time scale.* Does the scope offer both linear sweep and logarithmic sweep? A log sweep can be invaluable when looking at a long sequence of events.

- *Direct multichannel digital inputs.* As described earlier in this book, some scopes offer multichannel (at least four) inputs for looking at four digital signals simultaneously. Usually the allowable voltage range for these inputs is less than allowed for analog channels A and B, but sufficient for normal digital signals.

Anything else? Is there any end to this list? Of course not. When an oscilloscope is based on a digital processor, anything that can be imagined as a function for a digital processor can be programmed. There is a cost, but as was noted in the first paragraph of this chapter. Your first task is to decide what you want to do with the scope.

Other Features and Types

Limitations

As discussed in Chapter 7, some advanced digital scopes include test instruments, taking advantage of the memory and processor used in the basic oscilloscope. Usually, each of these features are specified in some detail. As an example, where an FFT (Fast Fourier Processor) is included, the number of points and speed are also specified. There are, however, several cautions to be noted. First, if the A/D and analog front end are limits on the scope bandwidth, the included other functions will be limited to these bandwidths. Don't expect a 30 MHz bandwidth scope to show signal spectrum to 500 MHz!

Next, while digital processors and their associated memory are very capable of being programmed as signal function generators, many of these capabilities and others cannot be used simultaneously with the oscilloscope functions. Thus if there is a signal generator that you plan to use to test a circuit, selecting the signal generator function may disable the scope function.

Interfaces, Connections, and Additions

Not listed in Chapter 7, but of some importance, is the ability of some scopes to be connected to analysis or simulation programs such as *MATLAB*, or to other hardware — perhaps a large capacity recorder. Since these functions and the general complexity of some modern oscilloscopes can be rather high, you might look for detailed user instructions and video demonstrations on the CD or DVD that comes with the scope. Usually the CD contains the user manual and other information.

Just One More Type of Oscilloscope

Available for download, often free and very interesting, is the set of hardware-free oscilloscopes. These use a personal computer sound card as the channel connections. The software, similar to that used with hardware scopes that connect to a PC via a USB connection, is hosted on the PC.

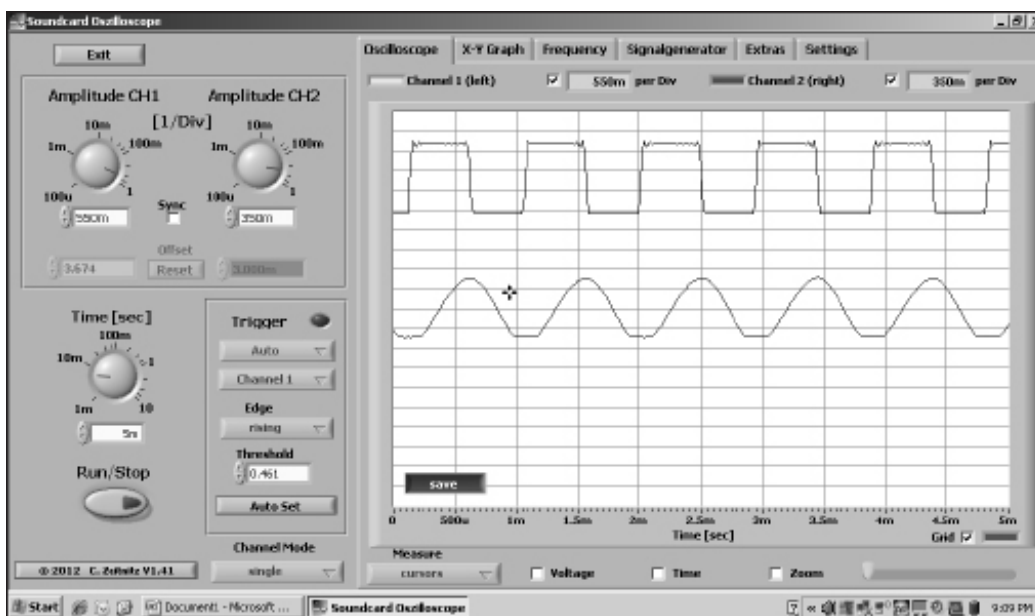

Figure 8.9 — If the text did not give it away, you would not have guessed this is the on-screen display of a no-hardware scope. The clue is the time scale, where you can see the input waveform frequency is close to 1 kHz — an audio frequency.

There are, of course, cautions and limitations associated with this approach. Since the sound card is interfaced with (sometimes) unknown signals, protection for your sound card is strongly suggested. A protection circuit for this situation is given in Chapter 7.

Figure 8.9 is a screen shot from one such scope. Downloading and setting it up takes only a few minutes. However, the bandwidth, in this case, is limited to the capability of your sound card. Generally, for sine waves, this means a lower frequency limit of perhaps 20 Hz and an upper frequency limit of 20 kHz.

For pulses and other non-sinusoidal signals where Fourier analysis predicts frequency content of multiples of the base waveshape, the best you can obtain without serious distortion is perhaps 20 kHz divided by 5, so that the 5th harmonic energy will be passed and the displayed waveform recognizable. Since the source of these scopes is the Internet, and names, addresses and cost (if any) are constantly changing it will probably take you as much time to find one of these software scopes on line as it will to download it and get it working!

Appendix 1

Software Oscilloscopes — Capable and Free!

Over the years, I have seen and used a wide variety of oscilloscopes in my home workshop. They all had one thing in common — a cost.

As discussed in earlier chapters, there are still quite a few old-line analog oscilloscopes for sale — self-contained with a large CRT facing out of the front panel. The newer generations of scopes are digitally based, where after some small analog input circuits the signal goes into one or two analog-to-digital (A/D) converters. From this point on the signals you want to see are in a computer of sorts built into the scope. In fact some modern scopes don't include this computation ability but connect to your personal computer.

More recent is a new set of oscilloscopes that are tiny enough to fit in your shirt pocket. Digilent makes a unit that interfaces through a USB port to a PC. Another unit made by Oscium connects to an iPhone, iPod or iPad (see Appendix 3). Unfortunately these ultra-miniature scopes have a limited frequency bandwidth.

Another option is a scope requiring no hardware! Since today's scopes are primarily software, running in some sort of computer, it seems that all you need is a front end consisting of an A/D converter. You already have A/D converters built into your PC — the sound card. Why not use that?

This is exactly what others realized, and there are probably a dozen, or perhaps even more, software-only scopes available for download on the Internet. Many of them are free for ham use. As with any download program, an active virus or malware checker is an absolute necessity before running such a program.

What's The Catch?

There are really two major limitations to using a software-only scope. The first is that the signal to be seen is connected directly to the sound card. If this signal voltage is too high — poof goes the sound card (or even worse, the sound card circuitry on the mother board!). Therefore a simple protection circuit, such as the one described in Chapter 7, is needed to protect the sound card. Be sure to take the time to build an adequate protection circuit!

The second limitation is frequency. You can generally get reasonable results on sine waves up to the sound card limit of 20 kHz or so, but as the figures in this Appendix show, non-sinusoidal waveforms can be badly distorted as their repetition frequency goes up.

What Do You Get Free?

As noted before, there are many software scopes available. *Soundcard Oscilloscope*, V1.41 by Christian Zeitnitz (www.zeitnitz.eu/scope_en) was used here to show the features and limitations typical of these scopes. Make no mistake, this is a full featured, stable and in fact fun-to-use test instrument within its limitations (primarily frequency limitations).

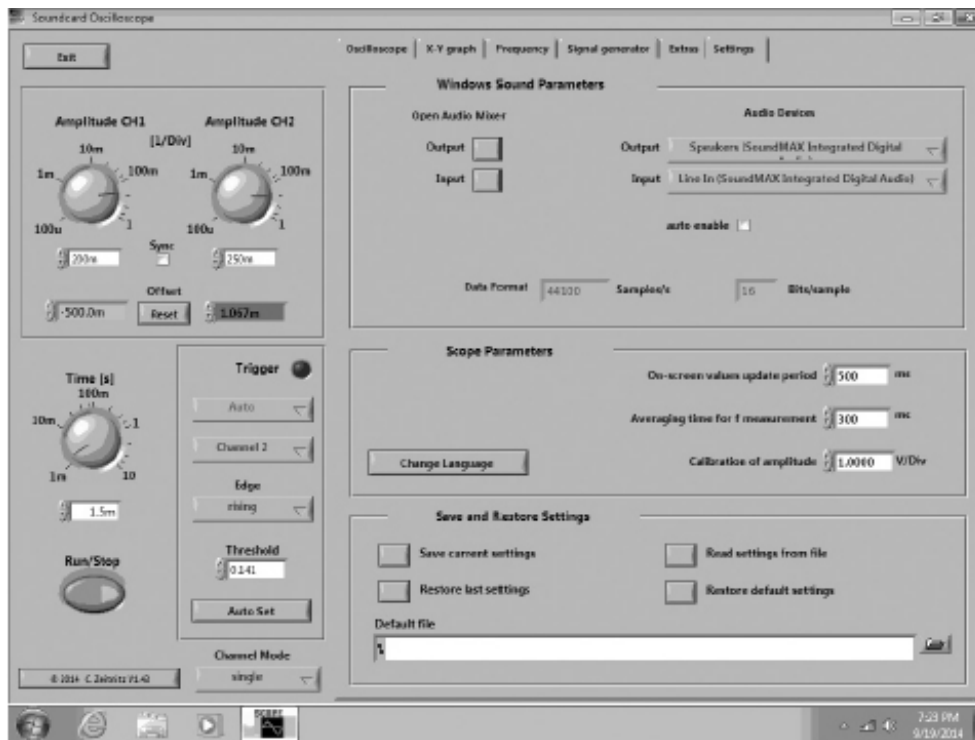

Figure A1.1 — The SETTINGS tab controls the interface to the PC and allows you to store your scope settings.

The tests and resulting pictures here were made using both a three-year-old Pentium PC running *Windows 7* and a five-year-old Asus Netbook, running *Windows XP*. There was no noticeable performance difference with either computer.

Soundcard Oscilloscope comes with a 16-page manual in PDF format and built-in help files. As usual with software documentation and help files, many questions go unanswered, but a little experimentation often answers the question.

The scope output plugs into the LINE INPUT jack of the soundcard. Because the scope is dual channel, a dual channel (or stereo) input is needed. On most PCs the microphone input is monaural and will not be suitable.

When you bring up the software, after the licensing notice, a set of tabs on top are used to select what you want to do. **Figure A1.1** shows the SETTINGS tab. As you can see the input selected for the PC is LINE IN. Next you can go to the OSCILLOSCOPE tab and make the required time base and voltage settings. Then back to the SETTINGS tab and save your settings for future use. Also check that the sound card settings in your PC have the gain for LINE IN turned up.

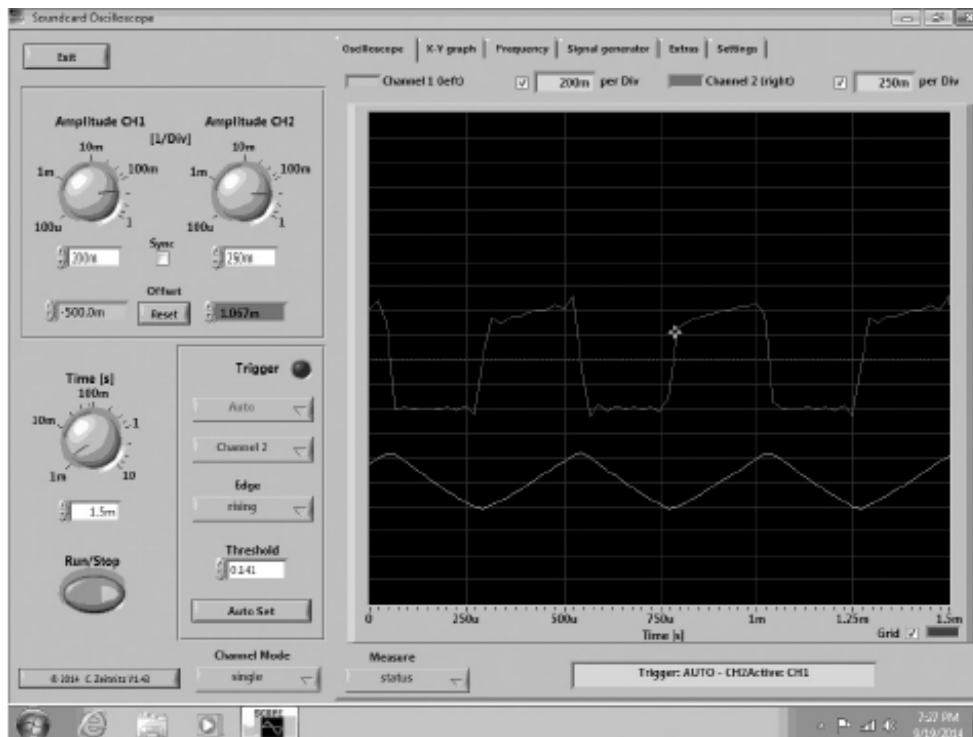

Figure A1.2 — This is how an imperfect square wave and a triangular wave look on the scope screen. The two waveforms are synchronized in the signal generator.

Figure A1.2 shows the screen when the OSCILLOSCOPE tab has been selected. Voltage calibration is not exact; the voltage scale is arbitrary and its range is a 16-bit number. However if you put a known waveform in one channel, you can get reasonable measurements by adjusting the cursor and comparing the unknown waveform with the known waveform. The relative accuracy is one part in 32,768. Between the amplitude controls and the resistors in the sound card protection circuit, you have to work a bit to adjust the system to show your waveform.

The horizontal sweep rate is calibrated in total range, presumably across the entire screen — not time per cm as in most scopes. Slightly confusing is the 1 CHANNEL mode (second column, near the bottom). 1 CHANNEL does not mean single channel; it means two separate channels as contrasted to the other available settings of adding and subtracting the two channels.

Figure A1.2 shows a roughly 2 kHz square wave and the same frequency triangular wave on the scope face. Notice that the square wave is relatively square — compare this to **Figure A1.3** where a 10 kHz square wave is shown.

Mathematically, by a technique known as Fourier analysis, a square wave can be shown to be made up of the sum of a sine wave at the fundamental frequency added to other sine waves at the third harmonic, fifth harmonic, seventh harmonic and so on — in other words all odd harmonics. Each harmonic has a specific amplitude. This is discussed in Chapter 4 and Chapter 7 of this book. The result is a display of a very distorted square wave when these harmonics fall outside the sound card's 20 kHz bandwidth. At least one software scope claims performance related to the sound card sampling rate — perhaps up to 96 kHz or more.

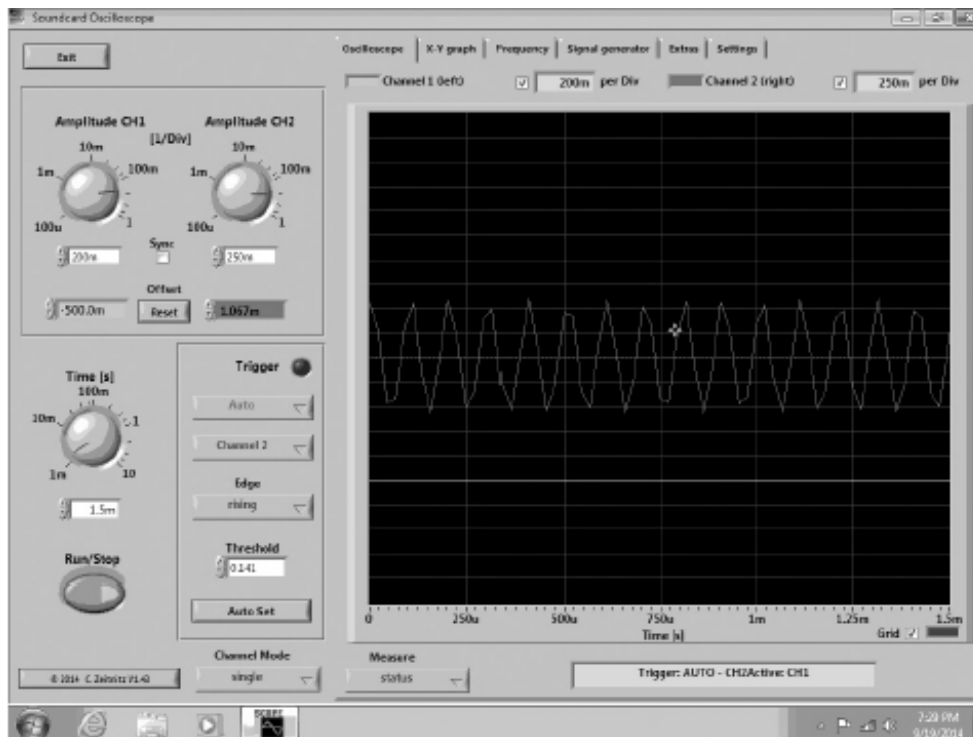

Figure A1.3 — The harmonics of a 10 kHz square wave are beyond the sound card bandwidth so the square wave appears distorted.

Figure A1.4 shows the display when the FREQUENCY tab is selected. This is actually a spectrum analyzer. Here a 1 kHz square wave shows the expected harmonics at 3 kHz, 5 kHz, 7 kHz and so on. Unfortunately, the amplitudes here are not shown accurately.

The SIGNAL GENERATOR tab, **Figure A1.5** provides a set of selected output waveforms, just as with expensive self-contained scopes. Another included capability is an audio recorder in the EXTRAS tab (**Figure A1.6**), which you could use to record the waveform under examination. Finally, the XY GRAPH tab allows you to see Lissajous figures, which could be very handy in comparing related audio frequencies.

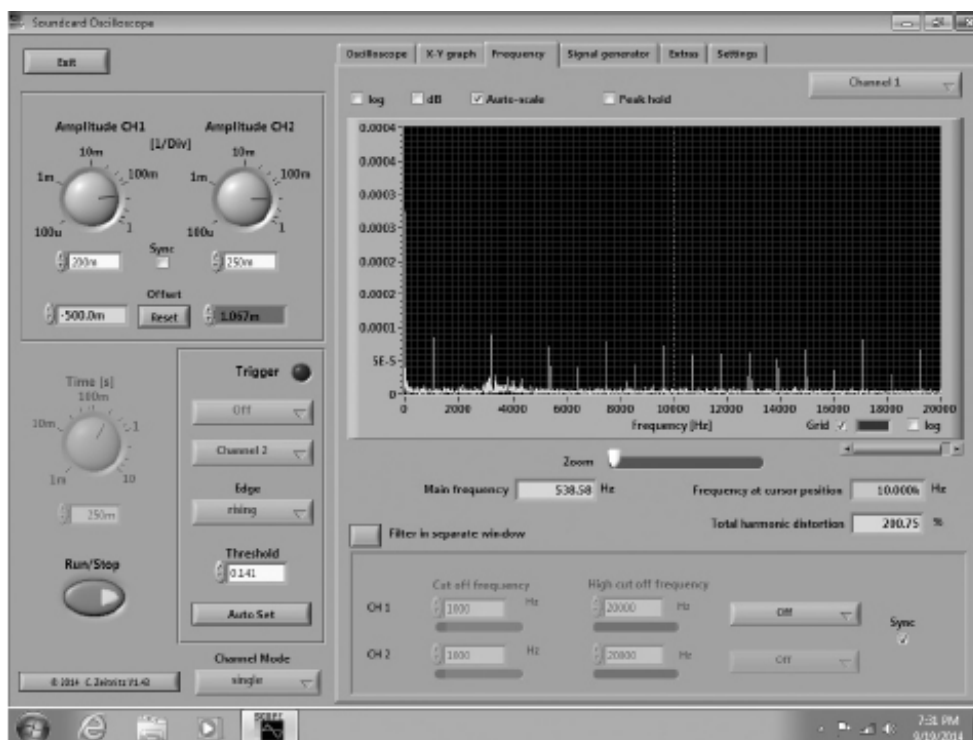

Figure A1.4 — The FREQUENCY tab selects a spectrum analyzer; however the relative amplitudes shown are not correct. Notice that the 1 kHz square wave has, as expected, harmonic energy at odd harmonics.

Figure A1.5 — Built-in is a signal generator offering a selection of four waveforms and white noise.

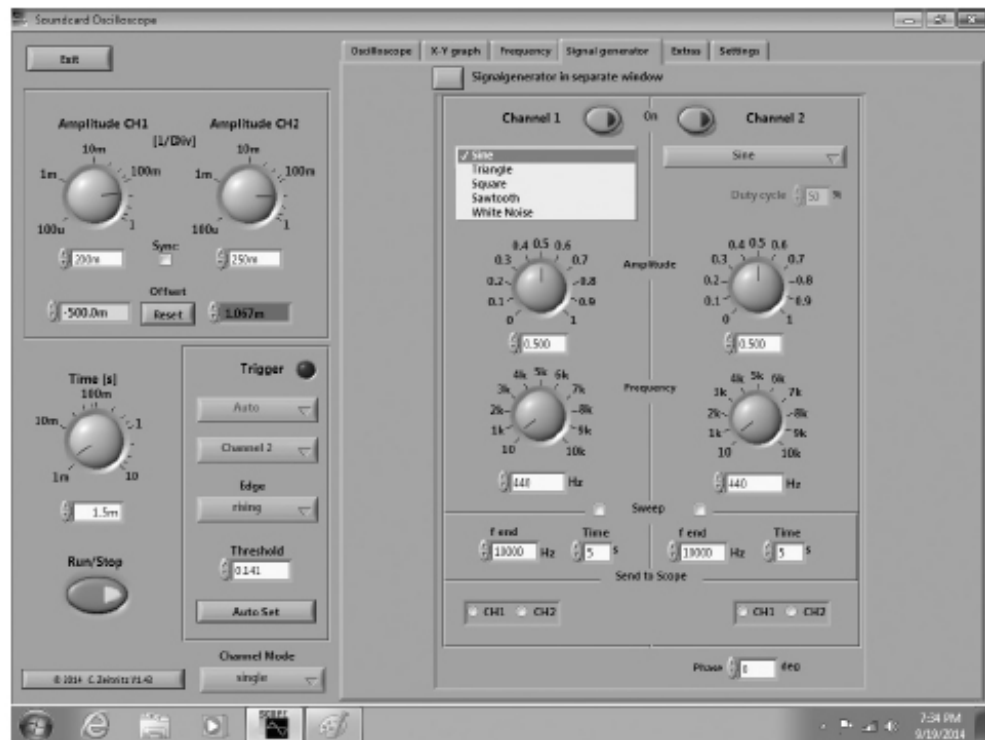
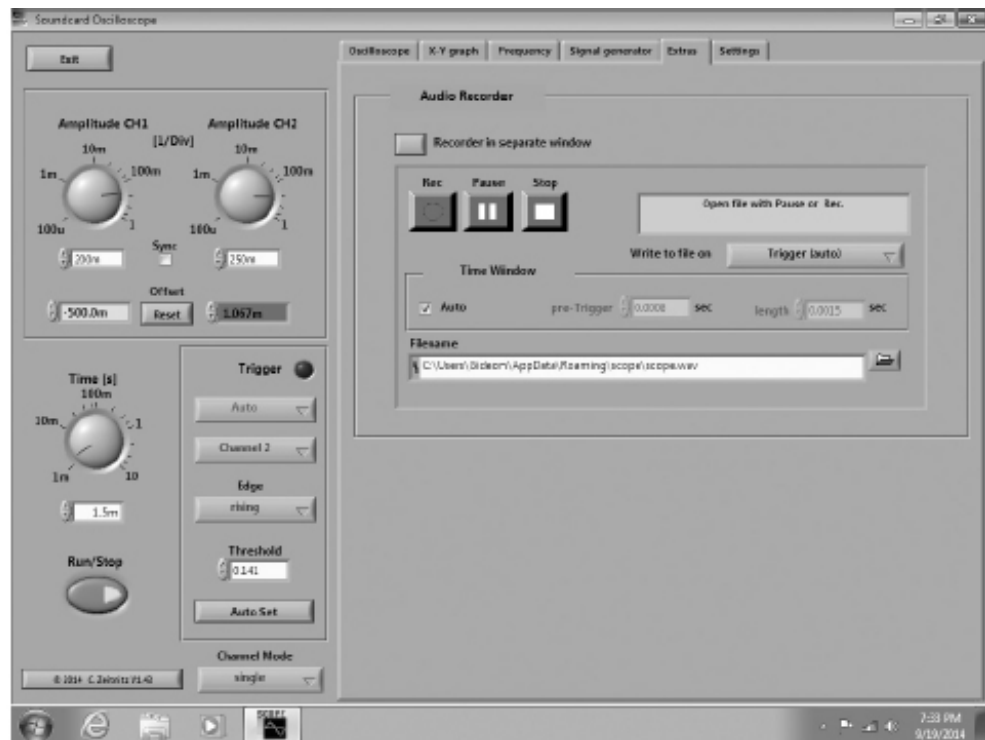

Figure A1.6 — The EXTRAS tab brings up an audio recorder, which allows you to record the waveform being examined.



Other Free Software Scopes

Many of the other available software scopes are quite similar to the one just described. A short Internet search will bring up both scope downloads and more information about these devices. A few versions include on-screen multipurpose voltmeters, frequency meters, ohmmeters, ammeters, and a large variety of other test equipment. Some require some external circuitry. A few use special sampling techniques that they claim allow use beyond the capability of the sound card — although probably only for a limited section of a waveform.

To see a fraction of what is available set your search engine to find the exact phrase “software oscilloscope” and the words “free” and “download.” Whatever the true capabilities of these scopes are the price is right. All you have to do is spend your time exploring these very useful programs.

Appendix 2

QST Product Review: Rigol DS1052E and Tektronix TBS1042 Oscilloscopes

This review, by Phil Salas, AD5X, originally appeared in October 2013 *QST*.

Most hams have basic test equipment consisting of at least a digital multimeter, SWR meter and dummy load. These three instruments provide the ability to do basic troubleshooting. Additional equipment often includes an accurate RF power meter, a frequency counter and an oscilloscope. Of these, historically the oscilloscope has been the most expensive, leading hams to explore the surplus equipment market. Used analog oscilloscopes can be quite good, but they are also large and inconvenient for recording data. If something goes wrong, they may be difficult and expensive to repair.

Digital sampling oscilloscopes (DSOs) have become available at prices justifiable for many ham experimenters. The two reviewed here provide features and capabilities that will satisfy most home users.

The Oscilloscope Decision Process

In the past, factors to be considered when choosing an oscilloscope included the number of simultaneous signals that you might need to measure, the bandwidth necessary, on-screen digital data readouts along with the waveform display, and spectrum analysis capability. With today's DSOs, the only decision you really need to make is the bandwidth required. As you increase the bandwidth requirement, though, the cost of the oscilloscope can increase significantly.

Table A2.1
Tektronix TBS1042 and Rigol DS1052E Basic Specifications

	Tektronix TBS1042	Rigol DS1052E
Bandwidth:	40 MHz	50 MHz
Analog channels:	2	2
Vertical sensitivity:	2 mV/div – 5 V/div	2 mV/div – 10 V/div
Real-time sample rate:	500 MSa/s	1 GSa/s (1 ch), 500 MSa/s (2 ch)
Vertical resolution	8 bits	8 bits
Max input voltage(RMS):	300 V @ 100 kHz, 13 V pk@3 MHz and above	300 V @ 30 kHz, 60 V @ 50 MHz
Probe impedance:	10:1 only — 10 M Ω /20 pF	1:1 — 1 M Ω /100 pF 10:1 — 10 M Ω /17 pF
Math:	+, -, x, FFT	+, -, x, FFT
Standard interface:	USB (front and rear)	USB (front and rear), RS232
Price (as of 10/2013):	\$680	\$329

With these factors in mind, this review focuses on Rigol and Tektronix DSOs with a 40 to 50 MHz bandwidth, as this is sufficient to permit most measurements desired at the lowest cost. As you can see in **Table A2.1**, these two instruments have very similar basic specifications. Detailed specifications can be found on the manufacturers' websites.

Let's Make a Few Tests

To see how the oscilloscopes perform, I selected several tests that I thought hams would find useful and interesting. For the first test, I looked at the measured frequency response of the oscilloscopes. I measured RF power with a calibrated setup and then checked the amplitude of the frequency on 7, 28 and 50 MHz. The Rigol has a 50 MHz bandwidth and the Tektronix has a 40 MHz bandwidth, so I would expect to see some rolloff on 10 and 6 meters. This doesn't mean you can't look at signals, just that the amplitude of higher frequency signals may not be completely accurate.

My next test involved measuring transmitter overshoot. When a transceiver's output power is reduced, often the transceiver output will overshoot (be higher than) the set power on the first CW character or speech syllable. This happens because a finite time is required for the transceiver's ALC to control the signal. If overshoot is high enough, it can trip protection circuitry in an external RF power amplifier or even damage it. For this test I set my Icom IC-706MKIIG transceiver to 25 W output, as this is the approximate drive power needed for full output from my Elecraft KPA500 amplifier.

Next I wanted to look at the amplifier enable/disable timing versus the RF signal output. This timing is important when driving an amplifier to ensure that no hot switching of the amplifier or transceiver takes place. (Hot switching means transmitting a signal before relay contacts have closed.) The amp key-to-RF signal and RF signal-to-amp unkey timings are both important because you want to make sure that there is no chance of hot switching on either amplifier keying or amplifier unkeying. I fed the IC-706MKIIG transceiver's HSEND output to channel 2 on the oscilloscope and set the oscilloscope to trigger on channel 2. A falling edge trigger shows the amp-enable timing, and a rising edge trigger shows the amp-disable timing. I could have fed HSEND into the EXTERNAL TRIGGER input on the oscilloscope, but I wanted to display HSEND along with the RF signal to better clarify the timing.

My final test involved two-tone testing of my transceiver. A two-tone test is a standard test of a transceiver's linearity that normally requires a spectrum analyzer. However, both oscilloscopes have a fast Fourier transform (FFT) math feature that should permit display of signals in the frequency domain. For this test, a two-tone audio signal is fed into the transceiver's microphone input, and the composite level adjusted for 25 W peak output. After displaying the normal modulated RF signal on the oscilloscope, select the FFT mode and make sure you are displaying in the dB scale. Use the vertical knob to select dB/division, the horizontal timing knob to select the Hz/division, and center the signal on your display with the horizontal position control.

Tektronix TBS1042

As with many computers and test instruments today, only a condensed version of the manual was enclosed with the TBS1042. The full manual (159 pages) is downloadable online. The only accessories provided with the oscilloscope are the 120 V ac power cord and a pair of 10:1 probes (not switchable to 1:1). For most measurements, you'll want to use a 10:1 probe because the capacitive loading of a 1:1 probe will be a problem for higher frequency RF signals. Also, a 10:1 probe provides better overload protection should you accidentally connect to a high voltage source. A 1:1 probe is most usable for audio measurements at very low signal levels.

An important feature of any instrument is its ease of use. Therefore I attempted to use the TBS1042 without reading the manual, other than reading about how to compensate the probes. As it turned out, I was able to quickly set up and measure everything in all the tests without cracking the book! What makes this easy is the AUTOSET button that sets up the unit for you. Just apply a signal and press AUTOSET. Within a few seconds you'll have a display that will be very close to what you want. From this point, you can simply change the vertical sensitivity and horizontal timing to refine the display to your liking.

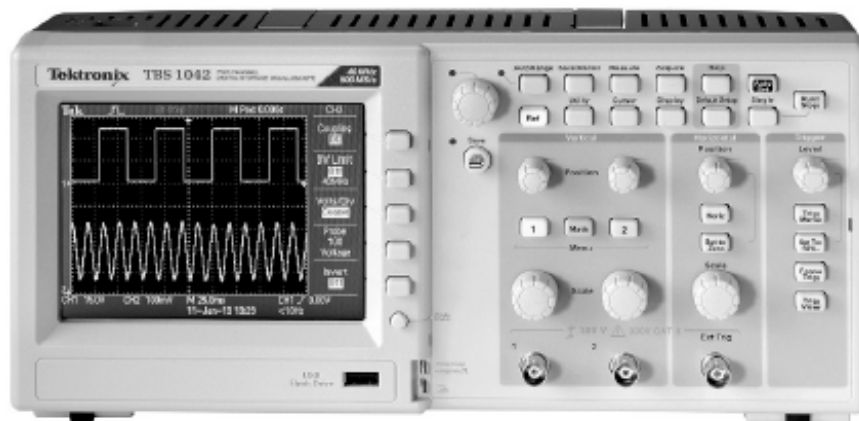

Table A2.2**Tektronix Storage Oscilloscope, Model TBS1042, s/n C010148****General Specifications:**

Display type: 5.6 inch diagonal color TFT LCD.

Display resolution: 320 horizontal × 240 vertical pixels.

Power consumption: 100-240 V ac, 50/60 Hz, 115 V RMS, 400 Hz

Operating environment: 32 – 104 °F, 5 to 85% relative humidity; 32 – 122 °F,
5 – 45% relative humidity, at <10,000 feet above sea level.

Input coupling: DC, AC, GND.

Input impedance 1 MΩ ±2%.

Size (HWD), weight: 6.2 × 12.9 × 4.9 inches, 4.4 pounds.

**The following specifications have been determined to be “as specified”
by Essco Laboratories, of Chelmsford, Massachusetts**

Sample rate range: 5 samples/second – 500 M samples/second.

Scanning speed: 5 ns/div – 50 s/div

Analog bandwidth: ≥30 MHz, (checked at 40 MHz)

Maximum input voltage: 300 V RMS.

DC gain accuracy: 5 mV/div – 10 mV/div.

Internal trigger sensitivity: 0.01 div – 5.0 div.

Trigger level range: ±8 divisions from center of screen (internal), ±1.6 V (external).

The USB port on the front of the unit provides either print or save functions. The TBS1042 determines if the connected device is a printer or memory stick, and will either print or save the screen data when the PRINT button is pushed.

The frequency response test resulted in a measured rolloff of 0.57 dB on 10 meters, and 1.67 dB on 6 meters, much better than the manufacturer’s 3 dB specification for the 40 MHz bandwidth.

For the overshoot test, I set my transceiver output to a nominal 25 W output level and triggered the TBS1042 on the channel 1 input. You have a choice of enabling either two horizontal cursors to measure amplitude, or two vertical cursors to measure time. I enabled the horizontal cursors to display the overshoot amplitude. The results are shown in **Figure A2.1**. Note that with a set output power of 25 W, the output peaks at 72 V peak (100 W) on the first dit

Next I looked at the amp-key enable (**Figure A2.2**) timing with the transceiver set for full break-in. The bottom trace is the amp-enable HSEND line from the radio. The results are interesting. The amp-enable-to-RF output time of 15 ms is fine for vacuum relays and PIN diodes. It is probably okay for open frame relays used on many amps not designed for full break-in (QSK) operation, but it is marginal. A typical enable time for open-frame relays is 12-20 ms.

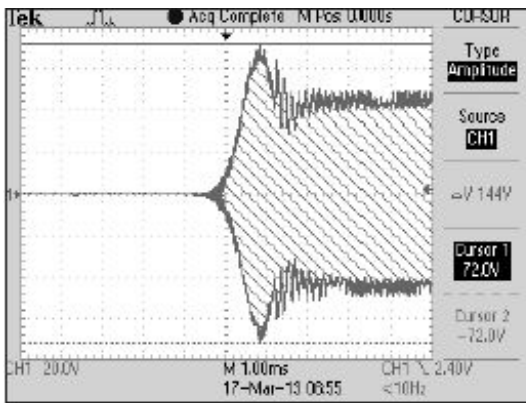

Figure A2.1 — Transceiver overshoot measurement with the Tektronix TBS1042.

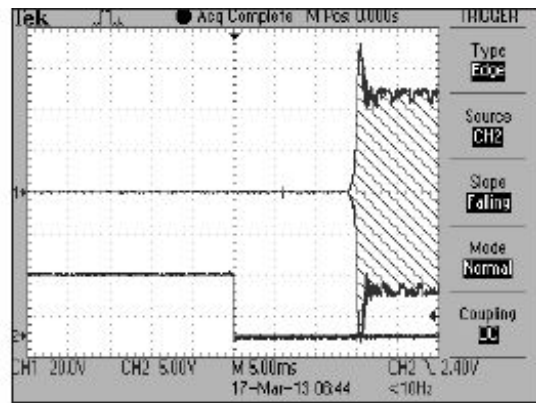

Figure A2.2 — Transceiver amp-key-to-RF-output timing measurement with the Tektronix TBS1042.

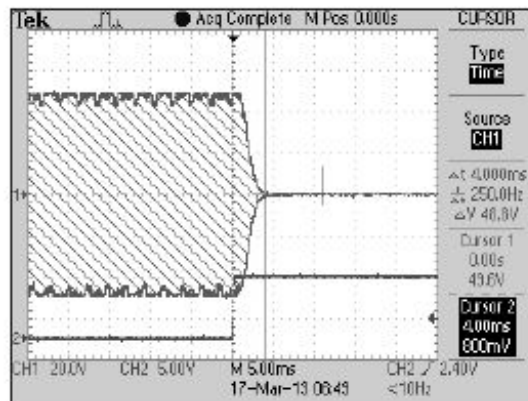

Figure A2.3 — Transceiver un-key/RF output timing measurement with the Tektronix TBS1042.

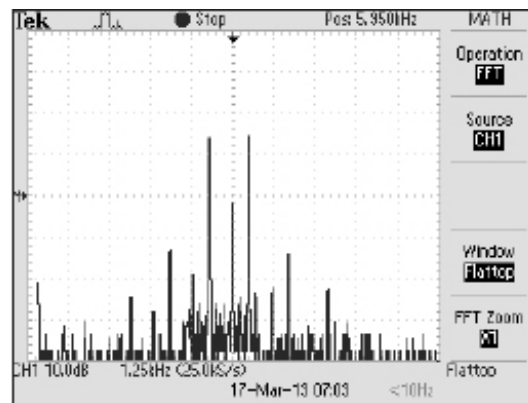

Figure A2.5 — Tektronix TBS1042 two-tone test FFT display using the same test setup as for Figure A2.4.

The amp disable timing (Figure A2.3) shows a problem with QSK-switched amplifiers. The amp disable line goes high about 4 ms *before* RF drops to zero (the vertical cursors were enabled to better show this). So you may hot switch an amplifier that is operating in QSK. To be on the safe side, IC-706MKIIG users should only operate semi break-in.

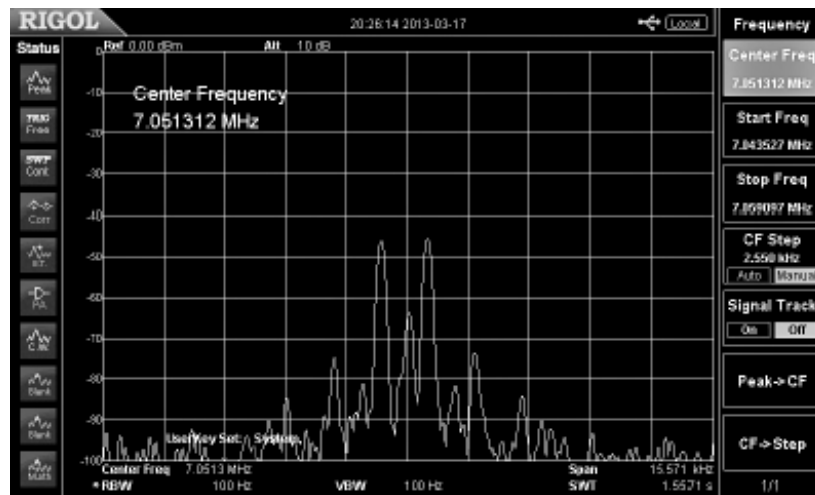

Figure A2.4 — Spectrum analyzer display of an SSB transceiver two-tone test.

My last test was a two-tone test of the transceiver output. **Figures A2.4** and **A2.5** compare the display of a spectrum analyzer (a Rigol DSA815-TG) with the FFT display on the TBS1042. As you can see, the TBS1042 frequency display is virtually identical to the spectrum analyzer, very useful for this type of measurement.

Manufacturer: Tektronix Inc, 14150 SW Karl Braun Dr, PO Box 500, Beaverton, OR 97077; www.tek.com.

Rigol DS1052E

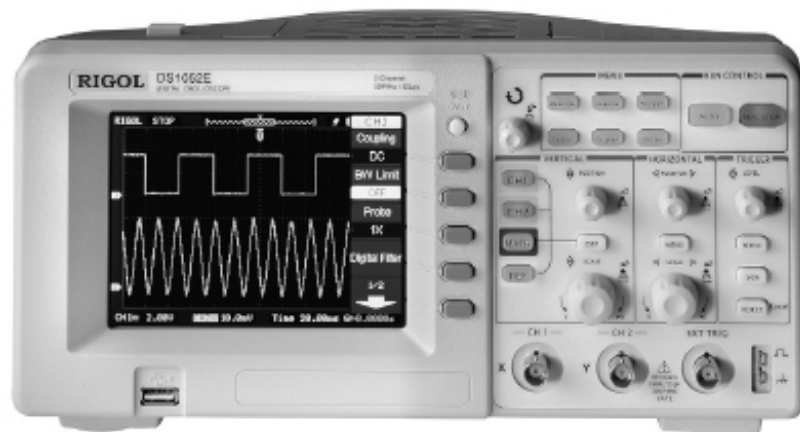

Table A2.3

Rigol Storage Oscilloscope, Model DS1052E, s/n DS1ED142306733

General Specifications:

Display type: 5.6 inch diagonal color TFT LCD.
Display resolution: 320 horizontal × 240 vertical pixels.
Power consumption: 100 – 240 V ac, 45 – 440 Hz.
Operating environment: 50 – 104 °F, ≤60% relative humidity; 50 – 95 °F, ≤90% relative humidity, at <10,000 feet above sea level.
Input coupling: DC, AC, GND.
Input impedance 1 MΩ ±2%.
Size (HWD), weight: 6.1 × 11.9 × 5.2 inches, 5.1 pounds.

The following specifications have been determined to be “as specified” by Essco Laboratories, of Chelmsford, Massachusetts

Sample rate range: 13.65 samples/second – 1 G samples/second.
Scanning speed: 5 ns/div – 50 s/div.
Analog bandwidth: 50 MHz.
Maximum input voltage: 300 V RMS.
DC gain accuracy: 2 mV/div – 5 mV/div.
Internal trigger sensitivity: 0.1 div – 1.0 div (adjustable).
Trigger level range: ±6 divisions from center of screen (internal), ±1.2 V (external).

The DS1052 did not include abbreviated instructions, but the full manual (166 pages) is downloadable online. The DS1052E includes a 120 V ac line cord, a pair of switchable 10:1/1:1 oscilloscope probes, and a USB cable for interfacing to your computer.

Again, I attempted to use the oscilloscope without reading the manual, other than the section on probe compensation. And again I had no problems. The AUTO button on the Rigol oscilloscope is equivalent to the AUTOSET button on the Tektronix oscilloscope. After applying a signal, press AUTO and then adjust the vertical sensitivity and horizontal timing to refine the display to your liking.

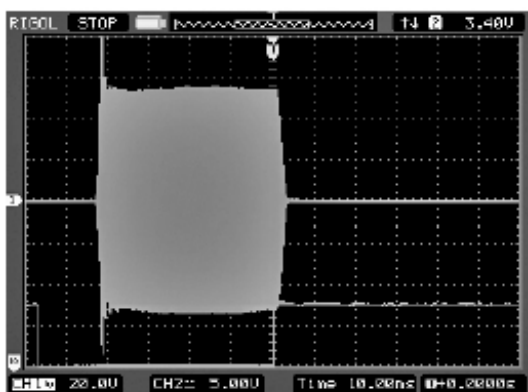

Figure A2.6 — Amp-key-to-RF-to-amp-disable timing using the Rigol DS1052E. Again, note the first dit overshoot.

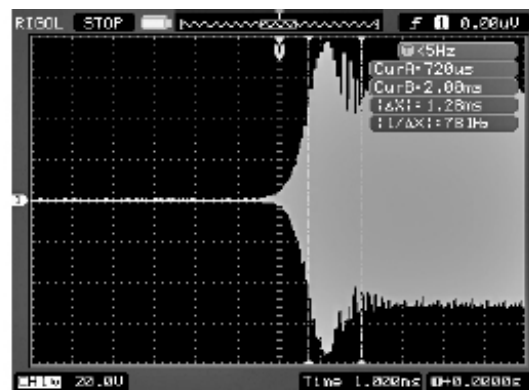

Figure A2.7 — A close-in view of the transceiver overshoot duration using the Rigol DS1052E.

The only thing I had problems with was saving the display to a USB memory stick. The SAVE procedure is very flexible, permitting you to save different formats and even permitting you to name the files. The SAVE process wasn't intuitive, requiring me to refer to the manual.

The frequency response test was interesting. The specification is for a 3 dB rolloff at 50 MHz, but I found no rolloff at all on 6 meters.

For the overshoot and amp-key/unkey timing tests, I found I could display everything at the same time. When I went to the TRIGGER menu I found that one of the options was triggering on both negative and positive going slopes of the triggering signal. This let me look at the amp-key HSEND going low on transmit and high on un-key, and the resultant RF signal — including overshoot. The resulting timing waveform is shown in **Figure A2.6**. The bottom trace is the amp-enable/disable (HSEND) line out of the IC-706MKIIG.

I also tested the overshoot and amp-disable timing separately so as to provide detail similar with the

Tektronix TBS1042 tests. I enabled the vertical cursors in both cases so as to more easily display the time. From the detailed view, I found that the first-dit overshoot lasts less than 2 ms (**Figure A2.7**) and on un-key, RF is still being output about 4 ms after the amp key line has gone high (**Figure A2.8**).

For the final test I attempted a two-tone test as I'd done with the Tektronix unit. **Figure A2.9** shows the time-domain two-tone RF-modulated signal. Apparently the Rigol DS1052E doesn't have enough buffer memory depth for the necessary resolution for two-tone testing (the buffer memory is where the captured samples are stored). There is plenty of resolution to show the main signal and its harmonics, but close-in signal resolution is not practical.

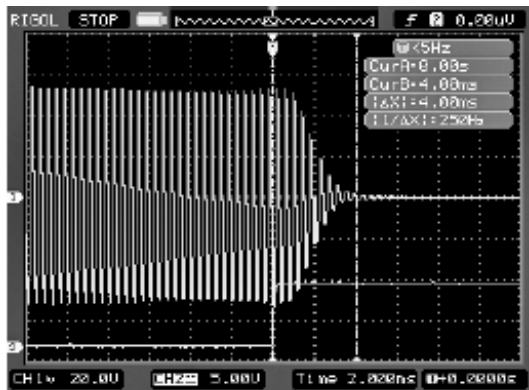

Figure A2.8 — Transceiver un-key/RF output timing detail viewed on the Rigol DS1052E.

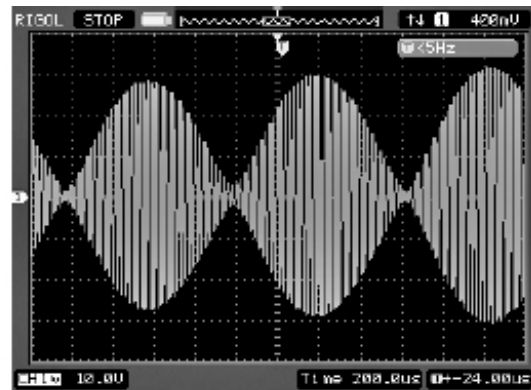

Figure A2.9 — Two-tone RF-modulated transceiver output measurement with the Rigol DS1052E using the same test setup as for Figures A2.4 and A2.5.

Manufacturer: Rigol Technologies Inc., 7401 First Place, Suite N, Oakwood Village, OH 44146; www.rigolna.com.

Some Final Observations

I did notice a few other differences between these two oscilloscopes that are worthwhile to point out.

Both oscilloscopes have a 5.7 inch diagonal color display. However, you can turn off the right-side menu on the Rigol, which provides a little more display area than on the Tektronix. The Tektronix oscilloscope takes about 30 seconds to boot up, whereas the Rigol is up and running in less than 10 seconds. Also, the Tektronix takes about 30 seconds to save a file to a USB memory stick, whereas the Rigol takes about 1 second. And I did like the Rigol's ability to trigger on both a positive and negative trigger on the same display. However, the Tektronix oscilloscope's ability to display a frequency domain two-tone test spectrum is important to me.

Somewhat off-topic, I would like to encourage the ARRL Lab to include transceiver overshoot and transceiver amplifier enable/disable output timing measurements with reviews of HF transceivers. These parameters are becoming increasingly important when interfacing a transceiver to an amplifier — especially when the amplifier is solid-state.

Conclusion

For hams who want to step up to the next level of testing, troubleshooting and understanding equipment performance, an oscilloscope becomes more of a necessity. Fortunately, digital sampling oscilloscopes have become surprisingly affordable. The two oscilloscopes discussed here will provide most of the capabilities desired by the more sophisticated ham at a price that is easily justifiable.

Appendix 3

QST Product Review: Oscium iMSO-

204 Portable Oscilloscope

This review, by Paul Danzer, N1II, originally appeared in June 2014 *QST*.

Some years ago (OK, many years ago) I was a young engineer, assigned to conduct tests on a US Navy ship used to evaluate various electronic devices. When I drove up to the pier late one Sunday evening, the men on duty at the gang plank had an order to allow me onto the ship, but there was no one else around to help me. The test was supposed to start early Monday morning and I had a 70+ pound Tektronix oscilloscope that had to be carried up three flights of stairs to the test room. The navy calls the stairs *ladders*; I called them *torture* — 70+ pounds, three flights of stairs!

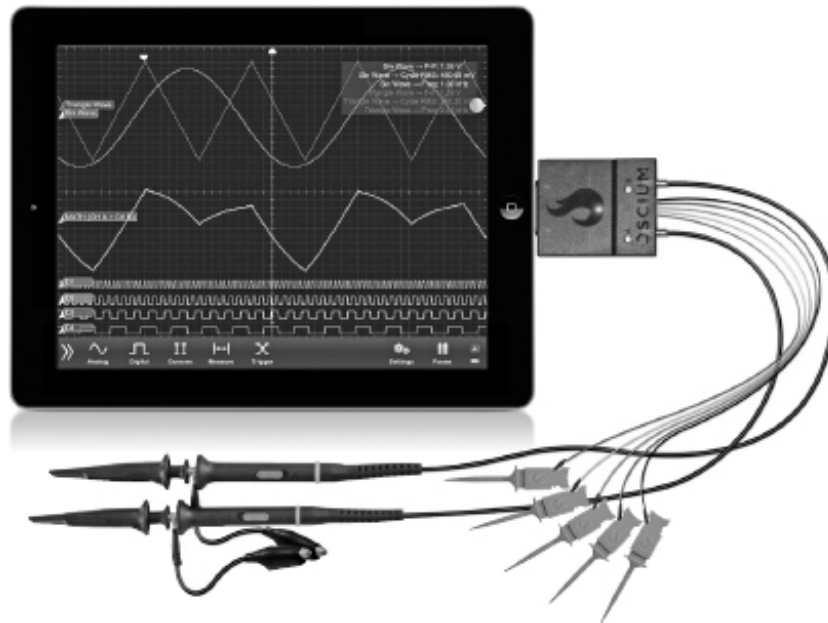

Table A3.1
Oscium iMSO-204 Portable Oscilloscope

Manufacturer's Specifications

Display	9.7 inch (iPad), 7.9 inch (iPad mini), 4.0 or 3.5 inch (iPhone, iPod).
Resolution	2048 × 1536 (iPad, iPad mini retina), 1024 × 768 (iPad mini), 1136 × 640 (iPod, iPhone).
Analog inputs	2 channel, 8 bit.
Analog probe	1× and 10× selectable, removable with SMB.
Digital inputs	4 channels.
Digital probe	4 bit, 1 ground, 0.100 inch connectors with removable SMD grabbers.
Analog bandwidth	5 MHz.
Max sample rate	50 MSPS.
Sample depth	1000 points.
Horizontal sensitivity	200 ns/div to 10 s/div.
Vertical sensitivity	50 mV/div to 2 V/div (1×); 500 mV/div to 20 V/div (10×).
Max digital input voltage	−0.5 to +7 V.
Max analog input voltage	−8 to +13 V (1×), −40 to +40 V (10×).
Coupling	ac or dc.
Trigger modes	Auto/Normal/Single/Stop.
Trigger types	Analog, Digital (A, A&B, A B, A B).
Price (as of June 2014):	iMSO-204 (30-pin compatible), \$399.97; with <i>Lightning</i> adapter, \$436.96.

I had forgotten about this incident until the Oscium iMSO-204 portable oscilloscope was delivered to my

door. And portable it is! It's shirt pocket size, and the weight is obviously not a problem — the problem is to not lose it in your pocket.

The oscilloscope connects to an Apple device — iPad, iPhone or iPod — supplied by the user. The Apple device runs the control software and provides the oscilloscope display and user interface. Of course, the display is best seen when the scope is plugged into an iPad, which has a nominal 9.7 inch (diagonal) display, or the slightly smaller 7.9 inch iPad mini. Be prepared to look closely if you use the scope with the small display on an iPhone or iPod.

Generally speaking, the display scales are controlled by the touch screen techniques you expect for mobile devices. Once you pick the correct menu item, you can pinch to make the scale smaller or slide your finger wider to make it bigger. Given a list, slide your finger up or down from the current setting to the new setting.

There are two Oscium oscilloscope models available. This review features the iMSO-204, which has two analog and four digital channel inputs. The less capable (and less expensive) iMSO-104 has a single analog channel and differences in the detailed specifications.

Given its size, can the iMSO-204 really replace a scope with a built-in 6 inch display and a front panel full of knobs? Will it really replace a larger computer-controlled unit that requires a PC or laptop to work?

Why is It So Small?

The answer, of course, is that with the increasing speed and accuracy of analog-to-digital (A/D) converters, less analog circuitry is needed up front. Other than some signal switching, selection of ac or dc coupling and perhaps some protection circuitry, you could go directly into an A/D converter and send the output to an external digital processor. Voltage scaling, triggering, level shifting and formatting for display is all done in software.

This is particularly true for digital inputs, where the A/D converters are not needed. Oscium specifies the digital inputs for -0.5 to $+7$ V. Depending on the probe settings ($\times 1$ or $\times 10$), the analog inputs are limited to -8 to $+13$ V or -40 to $+40$ V — certainly sufficient for today's solid state circuits.

Getting Started

First you have to download the software (free, of course) from the Apple store (go to www.oscium.com/oscilloscopes/imso-204 and click the download button on this page).

Next, connect the probes. The probes for the two analog input channels slide in, no problem. To use the four digital channel inputs, the digital connectors — four wires plus a ground — have to be plugged into a set of probes. Look carefully. The mating pins on the probes are at an angle — the wire sleeves slide in at that angle to connect. A magnifying glass might help! These connections are friction fits, so a hard pull may disconnect a probe from its connecting wire.

To fire up the scope, turn off your Apple device (from now on I am just going to refer to the device as an iPad). Then plug the scope into the iPad connector. In the last year or so Apple has changed connectors. The scope has an older 30 pin connector, but Oscium offers an optional adapter to connect the scope to devices with the newer *Lightning* connector.

Finally, turn on your iPad, select the OSCIUM icon, and you are set. Perhaps the first thing you will want to do is explore the functions. By touching the icon in the lower right corner the scope goes into a demo mode, where most, but not all functions are available.

Analog and Digital Scope Functions

The scope comes equipped with two conventional analog probes and two analog channels. The trigger icon at the bottom allows you to select the triggering source and mode. **Figure A3.1** shows the waveforms from two analog signals.



Figure A3.1 — Dual inputs at 100 kHz. The narrow rectangular pulses on channel A are not really synchronized with the triangular pulses on channel B. They only appear that way because the trigger selection was tweaked to make them line up.

Somewhat unusual are the four digital channels. They do not use an A/D converter — the probes connect directly to digital circuitry in the scope. When working with digital circuits, often you would like to look at more than two signals at a time. **Figure A3.2** shows the waveforms from four stages of a 4790 digital counter chip, wired as a divide-by-10 circuit (traces D1 to D4 at the bottom of the screen). Much to my surprise — although not captured in the screen shot — one of the stages showed “snivits” — short, narrow spikes due to slight mistiming built into the circuit. Since the snivits were on an intermediate stage, they did not affect the divide-by-10 feature.

A Good, Clear Picture

With older analog scopes, to get a good, clear picture you have to carefully adjust intensity (or brightness), focus, and triggering. With the iMSO-204, the first two are no longer a consideration because the display is synthesized in the digital realm. Triggering is still a critical factor. This scope does not have an external trigger input, but does offer a wide variety of trigger capabilities from the selected inputs.

When using the digital inputs, any of the four can be selected as the trigger. This is a very handy feature when looking at series circuits such as counters.

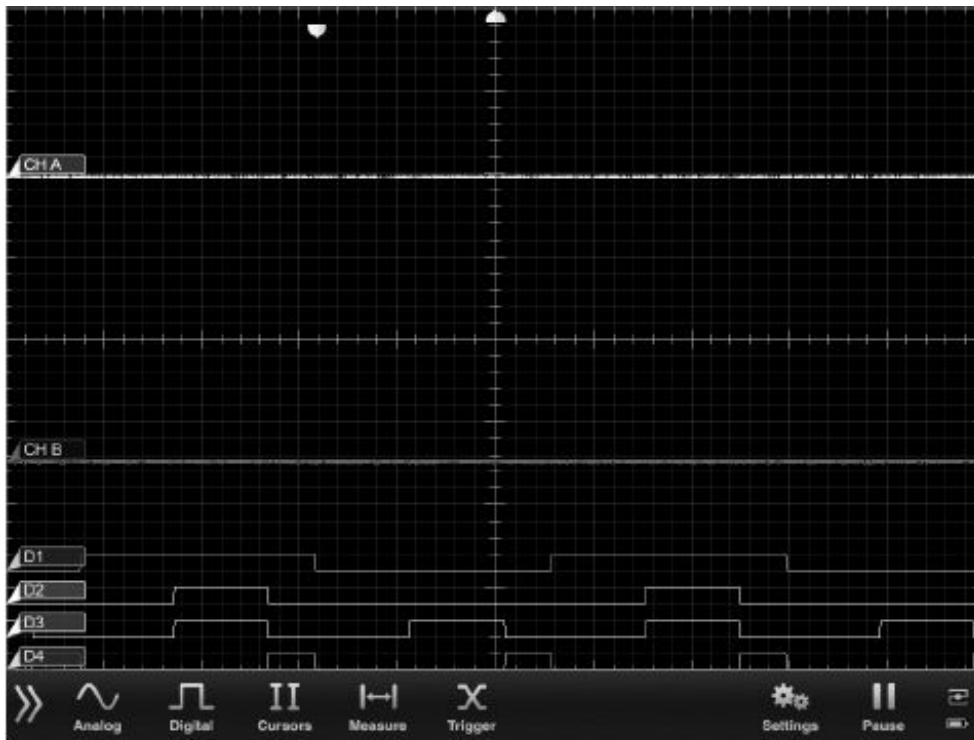

Figure A3.2 — The stages of a 4-flip-flop counter are connected to digital channels D1, D2, D3 and D4. Any digital channel can be selected to supply the trigger. In this screen shot channel D4 was selected.

The two analog inputs, A and B, may be combined or selected in various ways — either, alternate, or both as well as positive, negative, dc level, up slope and down slope — in other words a full assortment of trigger capabilities. By touching the TRIGGER icon on the bottom of the screen, the trigger selection menu in **Figure A3.3** comes up and you can select the actual trigger level. Your selection immediately goes into effect after you next touch a blank area of the screen and your waveform then becomes visible.



Figure A3.3 — The trigger selection menu has a variety of options. In this case analog channel A has been selected. Right now it show 0 V or ground has been selected, By taping on the LEVEL window a set of sliders appears that allows direct trigger voltage selection.

The Display

At the risk of upsetting touchscreen lovers, remember that the screen on many devices can be more sensitive than you expect. Some settings require more than one tap or a combination of taps and swipes. On occasion, the device will bring up menus and functions you did not expect. Oscium has designed their software so that if you touch an unoccupied portion of the screen, usually the software will revert to the previous state or display.

The scope technology used is one of sampling the inputs and digitally storing the result, so onscreen storage is a built-in function. In the lower right corner of **Figure A3.4** is a PLAY icon that sets either normal scope displays or a stop-stored display. You can look at an event either with a manual freeze or an automatically triggered freeze — very handy when chasing transients.

The Oscium software offers two functions for capturing and saving oscilloscope screen shots. One captures

the screen so it can be e-mailed (I didn't try this). The other stores a screen shot to the iPad photo storage, but the manual suggests you use the iPad's built-in picture store function, which is how the screen shots in this review were stored. The iPad's screen capture function requires pressing two buttons, and I found it "touchy," sometimes requiring a couple of tries. Just blame it on the operator!

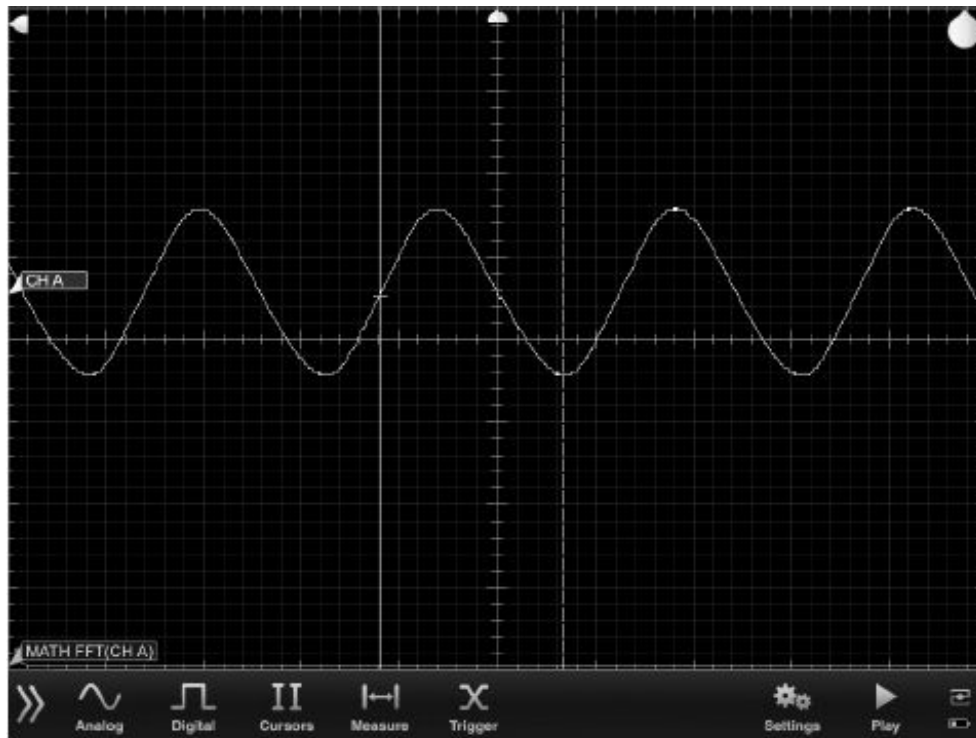

Figure A3.4 — At the lower right is the PLAY/STORE icon. The picture is one that has been stored on the screen; to leave the STORE mode and display real-time information requires a tap on the PLAY icon. Visible on the sine wave are sampling steps; the trace shows an input frequency well above the specified 5 MHz bandwidth.

Built-In Spectrum Analyzer

Many, if not most, of today's digital oscilloscopes include both an FFT (fast Fourier transform) analysis/display function and a signal/function generator. This scope does not include a generator, but does offer FFT, integration and differentiation. Admittedly it is not clear just how applicable the integration and differentiation functions are to most ham projects, but if you have them, you will probably find a use for them.

There is also a set of 15 very handy automatic measurement routines. These include, to quote from the manual: Minimum, Maximum, Mean, Peak to Peak, RMS, Duty Cycle (+), Duty Cycle (-), Pulse Width (+), Pulse Width (-), Cycle Mean, Cycle RMS, Frequency, Period, Rise Time, and Fall Time. Selecting these functions is quite simple, but understanding exactly what you are measuring takes a bit of practice.

Is It Capable Enough?

The answer to this question depends, of course, on what you want to do the iMSO-204. The bandwidth is specified as 5 MHz, but you can easily see sine waves — RF — to 14 MHz and beyond without known amplitude calibration. However, it is a sampling scope. The higher the frequency, the fewer the samples per sine wave, so perhaps the waveform shown at higher frequencies is less representative of the actual signal. In Figure A3.4 you can see the result of the sampling process where the actual input waveform is a smooth sinusoid but the display shows some increments. As you increase the input signal frequency beyond the 5 MHz bandwidth number — well beyond — this effect becomes more and more obvious.

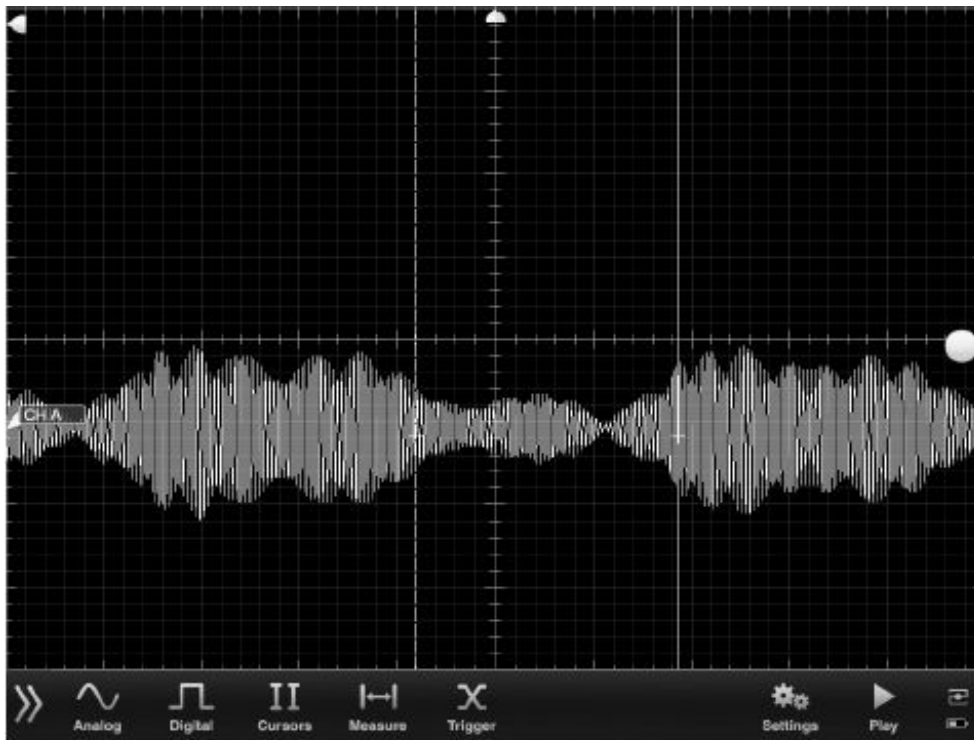

Figure A3.5 — With any scope you would like to see your transmitted signal looks like. Here is an SSB signal at 7 MHz The sweep speed and triggering was selected to show at least one syllable. Not too surprisingly the test voice word spoken into the microphone was “hello.”

Figure A3.5 is a screen capture of a 7.15 MHz SSB signal, taken at low power at a dummy load. This is past the rated 5 MHz bandwidth, and the scope was triggered to show syllables. Similar results were seen at 14 MHz, but of course the vertical calibration does not hold past the rated bandwidth.

One important factor — keep the input waveform amplitude down within the specified limits. Even if you do not damage anything, the waveform will be distorted if the input A/D is near its amplitude limit.

In Summary

If you need something very portable — for example on ARRL Field Day or when going to a restricted space to track down a transient on the local repeater — and you already own an iPad or similar device — this might be a good choice. The 5 MHz bandwidth is certainly a limitation, but it does show higher input signal frequencies.

Some skill and practice is needed to conquer a multifunction iPad with the Oscium software. It’s not as simple as, say, selecting a photo to view. As with most complex equipment, the instruction book does not cover everything. Some features are self-explanatory as seen on the screen; others not in the book require trial and exploration.

There are similar products, and at least one about the same size and with same bandwidth. However they require a laptop (or PC) and thus are not as portable and convenient.

As a replacement for your normal bench oscilloscope, this is probably not the best choice. But for its unique characteristics — size and portability — it works, and well enough to include in your proverbial portable tool box.

To get a better idea of how the iMSO-204 works, you can download the manual from the Oscium website and the software from the Apple store. The manual explains how to turn on and use the demo mode without having the scope hardware.

Manufacturer: Oscium, A Dechnia LLC, 5909 NW Expressway, Suite 269, Oklahoma City, OK 73132; www.oscium.com.